

THE THEORY, DESIGN
AND CONSTRUCTION
OF
INDUCTION COILS

BY

H. ARMAGNAT

TRANSLATED AND EDITED BY

OTIS ALLEN KENYON

*Editor and translator of Michalko's "Stray Currents from Electric
Railways," and Claudel's "Handbook of Mathematics."*

NEW YORK
McGRAW PUBLISHING COMPANY
1908

Copyrighted 1908
by the
McGraw Publishing Company
New York

PREFACE.

Although the induction coil is one of the oldest forms of electrical apparatus, comparatively little progress has been made toward rendering its design an exact science. There are several reasons for this lack of progress, the most important of which are the following: The limited field of application, the method of rating by length of secondary spark, erroneous assumptions in the mathematical treatment of the theory, non-uniform performance of interrupters, and lack of instruments suitable for experimental study of the performance.

The field of application has within the past few years spread from the laboratory and lecture room to medicine, radiology, wireless telegraphy, gas-engine ignition, etc., so that to-day the induction coil is as much a commercial machine as is the electric motor. The constantly growing commercial importance of this type of apparatus and the lack of an exact and definite treatment of its theory and performance, determined the writer to undertake the translation of H. Armagnat's most excellent work.

In this work the author has recognized the extreme importance of the interrupter, and has devoted a generous portion of the work to the treatment of the theory, construction and operation of the various types now used.

It is well known that the design of induction coils is almost entirely empirical, due to the lack of exact knowledge upon which a practical working theory can be based. H. Armagnat has done much toward clearing up the obscure points, and his work marks a decided advance toward the day when the induction coil will be calculated for a given service with the same assurance and accuracy

66077

as we now calculate transformers. All of the author's theoretical deductions are based upon and checked up with actual results, and the book contains a selected collection of oscillograms illustrating the points under discussion.

To the bibliography covering the period from the beginning to 1904, the translator has added the most important articles which have appeared up to date.

New York, March 2, 1908.

THE TRANSLATOR.

CONTENTS.

CHAPTER.	
I.	INTRODUCTION 1
II.	HISTORY 7
III.	THEORY OF MECHANICAL INTERRUPTERS—Experimental demonstrations—The rupture or break spark..... 15
IV.	THEORY OF ELECTROLYTIC INTERRUPTERS..... 69
V.	THE SECONDARY CURRENT—Striking or disruptive voltages..... 72
VI.	POWER AND EFFICIENCY—Measurement of constants—Coil testing—Accidents and faults in coils..... 83
VII.	CONSTRUCTION OF INDUCTION COILS—The primary—The secondary—Dielectrics—Condensers—Dimensions and proportions—Types of induction coils... 94
VIII.	INTERRUPTERS—Solid-contact interrupters—Mercury interrupters—Diverse interrupters—Electrolytic interrupters—Interrupters for alternating current..... 119
IX.	SPECIAL APPARATUS—Tesla transformer—Resonators—Diverse systems..... 151
X.	USES OF INDUCTION COILS—Installation and regulation of induction coils—Charging large capacities—Radiography and radioscopy—Gas-engine ignition—Miscellaneous applications..... 164
XI.	BIBLIOGRAPHY 188
	INDEX..... 213

other hand circuits in which the lines do not leave the iron are called closed magnetic circuits (Fig. 3).

The secondary circuit consists of a coil, which is generally placed outside the primary coil and well insulated from it. The winding of the secondary coil comes into one of two general classes according to the method of winding. These

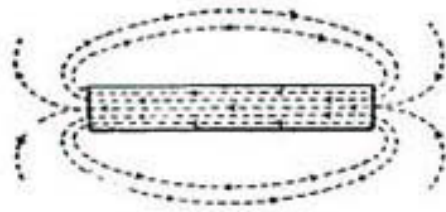

FIG. 2.

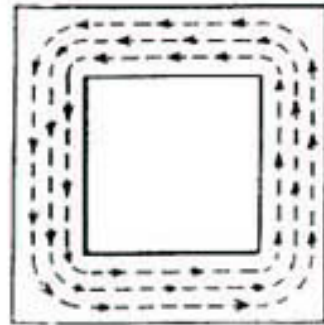

FIG. 3.

classes are the solenoid or cylindrical windings, and the helical or disk windings. The first is made by winding continuous spirals upon a cylindrical mandril (Fig. 4), while the second is composed of a number of elementary coils separated from each other by insulating disks and connected together (Fig. 5). No matter which sort of construction

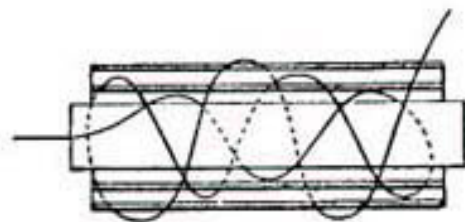

FIG. 4.

is used the ends of the winding are connected to the binding posts or terminals, $B B$ (Fig. 1).

In order to produce the fluctuations in the primary current which are necessary in order to generate e.m.fs. in the secondary, an interrupter, I , which periodically opens and closes the primary circuit, is connected between the winding

and the source, P . Interrupters may be divided into two classes, namely: Mechanical and electrolytic.

At the moment when the primary circuit is broken a spark is produced at the point of rupture, and at the same time a great deal larger discharge takes place across between the secondary terminals. The former is due to the self-induction of the primary circuit, which tends to maintain the current even after the circuit is opened. The latter is produced by the mutual induction between the primary and the secondary.

To distinguish between the two one is called the primary spark and the other the secondary spark, or simply spark.

In order to reduce the primary spark and increase the secondary spark, a condenser, K (Fig. 1), made of sheets of

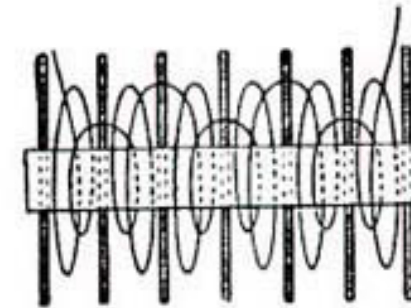

FIG. 5.

tin-foil, separated by sheets of insulation paper, mica, thin glass etc., is shunted around the interrupter, I .

The e.m.f. of the source causes the primary current to be established and the rupture of this current, by the interrupter, develops, in both circuits at the same time, e.m.fs. which are infinitely greater than that of the source; these e.m.fs. produce potential differences at the secondary terminals, $B B$, and at the point of rupture, which are sufficiently large to cause the sparks. The e.m.f. developed in the primary is called the e.m.f. of self-induction, the other is called the secondary e.m.f. The ratio between these two e.m.fs. is approximately equal to the ratio of the number of turns in the respective circuits. This ratio is called the ratio of transformation.

In order that the sparks may pass between two points, it is necessary that there exist between the points a potential difference, the value of which depends upon the form of the electrodes, the distance between them and the medium which separates them. The critical potential difference is called the striking voltage and the corresponding distance the striking distance. A spark can only be produced by breaking down the dielectric which is interposed between the electrodes; the striking voltage is greater according as the dielectric strength is greater. Unless specially stated, when we speak of striking voltage or striking distance, it is understood that the dielectric is air at atmospheric pressure.

When the interrupter closes the circuit, the current in the

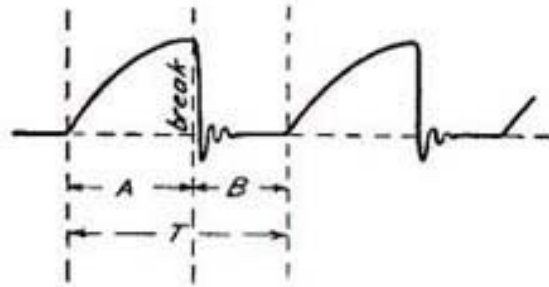

FIG. 6.

primary does not immediately reach its normal value, but increases at a rate which depends upon the self-induction and the resistance of the primary circuit (Fig. 6). This phase, A , is shown in the curve plotted between time and primary current. The form of this part of the curve depends upon the ratio of the coefficient of self-induction, L , of the primary circuit to its resistance, R ; this ratio $L \div R$ is called the time constant. After the circuit has been broken it remains open for a time, B . The sum, $A + B$ of these two times is called the period, T , of the interrupter; the reciprocal of the period is called the frequency of the interrupter. When in continuous operation the frequency is equal to the number of breaks per second.

At the moment when the circuit is broken, electric

oscillations are set up in both circuits. Since it is possible for these oscillations to have different periods, they are designated as primary oscillations or secondary oscillations according as they have their origin in the primary or secondary. The frequency of these oscillations is always defined as the reciprocal of their period and not by the number of oscillations per second. In fact a discharge can take place in a great many ways. The spark may be silent, clear yellow and surrounded by a corona; in which case it has a frequency very nearly equal to that of the secondary current. It may be white, and give off a crackling noise; in which case there are a great many discharges of exceptionally short periods for each secondary oscillation; these are called high-frequency sparks. That which is often called the frequency of the spark is nothing other than the frequency of the interrupter, because the eye perceives only one spark for each break of the circuit.

The value of the current in the primary may be taken as the maximum reached just at the moment of rupture; this is the most important value; and is called the initial value.

A continuous-current ammeter connected in the primary circuit will show simply the mean value; this value is useful simply in determining the current consumption; it does not throw any light upon the effect produced, since this depends upon the form of the current curve and the length of time, B , that the circuit is open. Sometimes alternating-current ammeters are used to measure the primary current; these instruments give the effective current values, that is, the square root of the mean value of current squared, a quantity which has nothing to do with the phenomena.

At each closing of the interrupter a certain amount of energy is stored in the primary, a part of this energy is released by the discharge in the secondary. The storing of this energy requires a time which is longer or shorter, according to the power of the source; but at the discharge, this quantity of energy is released in a very short time, giving an excessive power of short duration.

This explains why with a very small amount energy such powerful mechanical effects, such for instance, as piercing blocks of glass, can be produced. If the total number of discharges taking place during one second are considered, the mean value of the power output, which is much less than the instantaneous value, is obtained. The energy transformation does not take place without losses; the currents in the circuits cause heating; this consumes energy according to Joules law: *i.e.*, the copper loss. The iron in the core is alternately magnetized and demagnetized, and becomes heated by hysteresis. Because of these losses the energy output is but a fraction of the energy input; the efficiency is the ratio of these two, or it is the ratio between the mean power output and the mean power input. In this book no other use will be made of the word efficiency.

CHAPTER II.

HISTORY.

2. *Historical résumé*—The question of priority of discovery and construction of the induction coil, is indeed difficult to determine at the present day. The papers of that period give very vague indications; expressions are employed in so many different ways that we are obliged to fall back on later documents for accurate accounts. Eye witnesses themselves vary in their accounts. Du Moncel, for instance, after having, in his "Notice sur l'appareil d'induction de Ruhmkorff," attributed to Ruhmkorff all the credit of the practical realization of the induction coil, contradicts all this in his "Applications de l'électricité" 1873. The cause of this contradiction is a pamphlet by Page, "History of Induction" (B. No. 16),* published in America in 1867. This pamphlet is out of print and cannot be found to-day in the French libraries. This publication, which appears to have been a protest against the Volta prize awarded to Ruhmkorff, is above all, a long eulogy on Page, by himself. Unfortunately, there remain few documents which may be used to prove the affirmations made by Page, except as far as concerns induction coils, because in the papers of 1837, descriptions with illustrations of coils intended for medical applications are given, which leave no doubt as to their existence at this time.

The greatest difficulty in comparing the different memoirs, is caused by the continual confusion between the spark at rupture produced between the points where the rupture takes place and the secondary spark. The first requires a

* B followed by a number refers to the bibliography at the end of the book.

very small difference of potential in order to produce a spark between two points which are at first infinitely close together and are drawn apart; it is also assisted by the particles of metal, which in many of the early experiments were torn loose at the points of rupture. On the other hand, the secondary spark having to break down a gap of constant length, requires a much greater difference of potential. That which has long been called the Ruhmkorff coil, is a device permitting the formation of secondary sparks. To-day the name "induction coil" is most generally employed in this sense.

Induction having been discovered in 1831 by Faraday. The year following, Professor Henry of Princeton (B. No. 1) observed that a spark was produced by the rupture of a circuit, the spark being greater the longer the circuit. The fact attracted no notice; then in 1833 (B. No. 2) Dal Negro called attention to it again. The spark at rupture was due to the "extra current" at rupture, as was simultaneously found by Jenkins & Masson (B. No. 4).

During the following year 1835 (B. No. 3) Henry published another article, in which he shows that the effect of the rupture is increased when the wire is wound in spirals and when iron is placed inside of the spirals (Henry made his experiments with flat spirals). He notes the shock produced by the "extra current" and he tells of the ignition of explosive gas mixtures with the spark. He explains all these effects by the induction of the spirals upon one another.

In his memoir of 1837 (B. No. 4) Masson notes the same facts as Henry. He uses coils instead of spirals, and he points out the influence of iron in the coils, and the use of the toothed wheel for obtaining a succession of shocks.

In 1837 (B. No. 5) the name of Page appeared for the first time in Europe. The article reproduced in Sturgeon's "Annals of Electricity" is a letter dated from Salem, Massachusetts, May 12, 1836, which purports to have been published at this time in "Sillimann's Journal." In this memoir, together with the reproduction of Henry's experi-

ment, two important points should be noted: Page points out that the shock due to the "extra current" increases when the rupture of the circuit is produced in a layer of naphtha covering the mercury. He observes also shocks produced by touching the turns not traversed by the primary current. Page produces periodical interruptions by means of a copper star-wheel, which makes contact with a mercury surface. Sturgeon tells us, in an explanatory note, that the secondary current is obtained by placing two coils side by side, their windings always having a point in common.

In the same volume of Sturgeon's "Annals of Electricity" are found several interesting memoirs, one by Callan (B. No. 6), p. 295, relating to the construction of electromagnets in which iron is used to increase the effect of the rupture. Another note (B. No. 7), p. 477, refers to Henry's experiments, and contains the description of a coil intended for medical use. This coil, constructed according to specifications by Sturgeon, had two circuits: the primary, made up of 79 meters of heavy wire; and the secondary, 395 meters of fine wire—the core was hollow to permit the insertion of a bundle of iron wire. Fig. 125 in the same volume, presents for the first time to our knowledge, a coil which resembles in form, the classical model; it is a horizontal cylindrical coil above which is placed a walking beam operated by a connecting rod or a cam. The opposite end of the walking beam being provided with a rod which plunges in a cup of mercury. Fig. 127 in the same volume shows a similar coil having an interrupter in the form of a toothed wheel which rubs against a spring; this model was brought out by Bachhoffner. In these two illustrations the secondary is terminated by handles; these coils do not appear to be intended for the production of sparks.

In 1840 there appeared a new memoir by Henry (B. No. 8), where he reviews his former experiments. He studies the discharge of a Leyden jar in the primary, and observes the effects produced in the secondary.

In all the preceding memoirs, there was never a question of secondary sparks, and scarcely a word said of the luminous effect obtained by the rupture. In the memoir by Masson and Bréguet in 1841 (B. No. 9), for the first time reference is made to spark discharge. The interrupter employed by these physicians was composed of five brass toothed wheels; the notches between the teeth were filled with blocks of wood (Masson wheel), one of the wheels produced the rupture, and the other collected the current. The coil, which was 23 cm. long and 22 cm. in diameter, contained two equal wires, each 650 meters long; it charged a condenser electroscope, and obtained sparks from 2 mm. to 20 mm. long in the electric egg. Masson and Breguet note that, when the spark discharge occurs in the secondary, an indication may be given by an ordinary galvanometer connected in the circuit.

We come now to the period of practical realization, and are obliged, in order to respect all the rights, to give two versions: that of Page (B. No. 16), and that of Ruhmkorff (B. No. 19.)

We know the works of Page only through Du Moncel, who was familiar with the pamphlet "The History of Induction;" our description must, therefore, follow that of Du Moncel. In 1838, Page had constructed a coil having an iron core in the form of a horseshoe, and a mercury interrupter operated by a hammer attracted by the iron core itself; the mercury was covered with alcohol. The secondary current of this coil was of sufficient value to charge a Leyden jar. The secondary spark is said to have attained 1.57 millimeter ($\frac{1}{4}$ of an inch). From 1842-50, Page tells us that coils giving long sparks were constructed in America; some constructed before 1846 had fine wires several miles long (1609 meters), and giving from 2.5 to 12.5-millimeter sparks. Finally, in 1850, Page constructed a large coil giving 20-cm. sparks with a sudden rupture of the primary. This result seems indeed extraordinary, inasmuch as the use of the condenser was as yet unknown. The pamphlet by Page also makes a statement that the

interrupter known by the name of "Neef," was due to Professor MacGauley of Dublin (1837), and that it was perfected by Wagner, a friend of Neef.

When did Ruhmkorff commence to work on the induction coil, and when did he construct the first one? A biography of Ruhmkorff (B. No. 85), published in 1903, says that he commenced his work in 1843, and that a coil begun in 1848 was not yet finished in 1851. Dumas in his article for the Volta prize (B. No. 15), 1864, says: "From 1851, Ruhmkorff devoted himself to the construction and perfection of this apparatus." Finally, Ruhmkorff himself (B. No. 19) says: "In 1851 I constructed an induction coil."

From 1850 to 1860 was a period of great improvements. In 1853 (B. No. 10), Fizeau made a great improvement: the use of the condenser between the interrupter contact points; it was an improvement based upon an exact knowledge of the problem to be solved. His memoir is written in a very clear style, a remarkable thing for this epoch. Sinstedden having charged Leyden jars with secondary current before this, some authors have attributed to him the discovery of the use of condensers connected across the primary spark-gap. This is a confusion; the use of condensers in the primary and secondary being for entirely different purposes. The improvement by Fizeau increased the spark in free air to about 0.02 cm. (B. No. 17), p. 7.

As soon as the secondary e.m.f. was increased, the insulation had to be improved, and in 1852, Du Moncel says, (B. No. 20) p. 214, that Edw. and Chas. Bright constructed a coil in short sections separated by disks. This improvement is more generally attributed to Poggendorff, who described it very clearly in 1854 (B. No. 11). We should add that the English attributed the sectionalizing of coils to Siemens and Halske in Berlin, who exhibited at the Exposition in London, 1851, a coil constructed according to this system (B. No. 29), p. 99, and (B. No. 30), p. 41.

The sectionalizing is carried to excess in the system of Ritchie, in Boston, 1857 (B. No. 20), p. 242, where each

elementary coil is a flat spiral, having for its thickness the diameter of the wire itself; a great number of these sections is necessary to form a complete coil.

Another method of insulating these secondary turns was given in 1858 by an amateur, Jean (B. No. 14), who succeeded in constructing a coil giving 20-cm. sparks, by simply separating the layers of wires from each other by sheets of blotting paper. The coil was dried in an oven, then placed in a glass vase which was filled with rosin after vacuum had removed all traces of moisture. According to Du Moncel, the coil constructed by Jean appears to have astonished all those who saw it; it should be noted here that there was great variance in the publications of the epoch as to the length of sparks obtained.

Foucault, in 1856 (B. No. 12), undertakes to connect several coils together, so as to increase the sparks which he says scarcely exceeded from 8 to 10 millimeters at that time. By connecting four coils, the primaries in series and the secondaries likewise, he attained from 3 to 4-cm. sparks; then he states that three months later he obtained 7 to 8-cm. sparks. The following year, 1857, (B. No. 13), in describing a double mercury interrupter, Foucault said that the coils give sparks up to 20 cm. long. The German article already referred to (B. No. 5), says that Rhumkorff exhibited in 1855, in Paris, a coil giving 40-cm. sparks. Furthermore, it was not until 1859 that an American coil was seen in Europe (B. No. 17, p. 33), this was constructed by Ritchie, and gave sparks 35 cm. long. All these contradictions render it difficult to grasp the rôle played by each of the early constructors.

Poggendorff said, in a memoir in 1855 (B. No. 11), that an interrupter operated in rarefied air does not require the use of the condenser, the interruptions being more sudden, but the contact surface changes very rapidly.

In 1856 and 1857, Foucault constructed a mercury interrupter (B. No. 13).

From 1860 to 1896, the induction coil remained a laboratory instrument, having no great practical interest; how-

ever, we see the dawn of one of the great fields of application when, in 1860, Lenoir utilized the spark from an induction coil for igniting his gas motor. This period saw the construction of some large coils, which marked the progress in construction. In 1872 Ritchie constructed a coil for Professor Morton (B. No. 18), giving sparks up to 60 cm. long. This coil weighed 112 kg., and the secondary contained 71 kilometers of wire 0.18 millimeters in diameter, and made up of about 145,000 turns.

In 1886, the English builder Apps (B. No. 22 and 23), constructed a coil known by the name of its owner, Spottiswoode. This coil (Fig. 7) gave sparks up to 1.05 meters

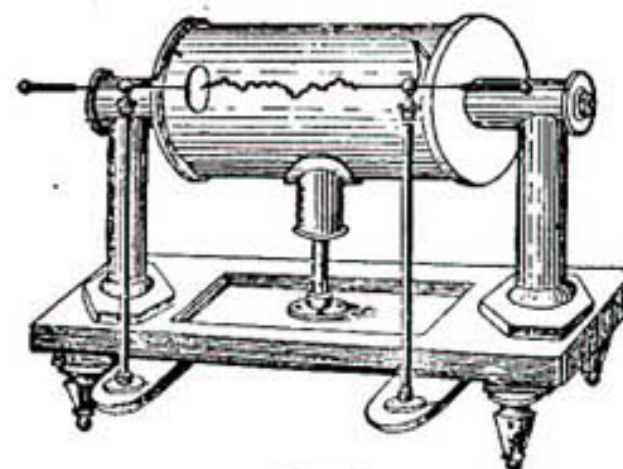

FIG. 7.

long, contains 450 kg. of wire, forming a total of 341,850 turns. The wire used was 0.38 millimeters in diameter in the end sections, and 0.24 millimeters in diameter in the middle. Two primaries were constructed; one which gave sparks 1.05 meters long, weighed 41 kg., and contained 1344 turns of wire.

Since this epoch, coils have rarely been constructed which give such long sparks; nevertheless, at the Exposition of 1900 several were shown. The constructor who appears to have best succeeded in this direction is Klingelfuss of Bale, whose large coils stand service well. These large coils remain objects of curiosity, without great practical

interest; in ordinary usage, sparks rarely exceed 60 cm. in length.

The discovery of Röntgen in 1896, gave an unawaited impetus to the construction of induction coils, and has produced very important modifications in the details, transforming the old laboratory apparatus into an almost commercial instrument. Wireless telegraphy came afterward, extending the field of application; and finally the development of the automobile has brought forward the construction of a considerable number of small coils for the ignition of motors. The steps of progress during the last period will be given as we proceed.

The last point to cite here is the discovery of the electrolytic interrupter by Wehnelt in 1899 (B. No. 44); this instrument rests on a principle entirely different from those used up to that time.

From the theoretical point of view, the first rational study of the induction coil was made by Mouton (B. No. 21), 1876, then follows the interesting mathematical work of Colley (B. No. 25). The later works will be found in the theoretical part and in the bibliography.

CHAPTER III.

THEORY—MECHANICAL INTERRUPTERS.

3. **Mechanical interrupters.**—Any variation in the value of the current in one circuit causes the generation of an e.m.f. in the same circuit and also in the adjacent circuit, the value of which is proportional to the rate of variation, $\frac{dI}{dt}$, and a coefficient, the value of which depends upon the character of the circuit.

The induction of the circuit upon itself is called self-induction; the e.m.f., e_1 , produced is proportional to the coefficient of self-induction, L :

$$e_1 = L \frac{dI}{dt}$$

The induction of the circuit upon the adjacent circuit is called mutual induction; the e.m.f., e_2 , produced is proportional to the coefficient of mutual induction, M :

$$e_2 = -M \frac{dI}{dt}$$

The e.m.fs. produced are such that the currents set up by them tend to oppose the variation of the primary current; they obey Lenz's law, which is nothing but a corollary of the law of the conservation of energy.

The coefficients of induction, M and L , are constants only when the coils contain no iron or other magnetic material. If there is iron present, these coefficients vary with the flux density and the induced e.m.fs. are proportional to the variation of flux, $\frac{d\phi}{dt}$, instead of simply to

the variation of the current. In the calculations which follow, the effect of the iron will be neglected, except in some special cases, and the coefficients of self-induction will be taken as constants.

A division in the theory is caused by the different phenomena produced by the employment of the mechanical interrupter and electrolytic interrupter. The mechanical interrupters will be considered first.

In developing the theory the schematic coil shown in Fig. 8 will be considered. The primary is connected to a source of e.m.f., E . Let the total resistance of the primary circuit be R , and its coefficient of self-induction be L ; and let a condenser of capacity C be connected in parallel with the interrupter, K . Let the secondary circuit have a resistance, r , a coefficient of self-induction, l , and a

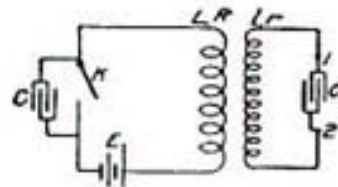

FIG. 8

capacity, c . The capacity is shown by the condenser connected across the terminals, 1 and 2, and represents the capacity of the secondary windings or of a condenser connected in the circuit. Since the sparks which form at the terminals, 1 and 2, and at the interrupter, K , cannot be taken into account, they are neglected in the calculation.

The fundamental equations of the schematic coil shown above are:

$$RI + L \frac{dI}{dt} + M \frac{di}{dt} + \frac{Q}{C} = E, \quad (1)$$

wherein I is the primary current (amperes)
 i " " secondary " (")
 Q " " charge of the condenser (coulombs).

$$ri + l \frac{di}{dt} + M \frac{dI}{dt} + \frac{q}{c} = 0. \quad (2)$$

Equation (1) is for the primary and equation (2) is for the secondary. The complete integration of these equations has never been accomplished, but a certain number of special cases have been studied; and we shall now examine the results of these.

Experience shows that the e.m.f. produced by closing the circuit is very different from that produced by opening the circuit; these two phases must be studied separately.

4. Closing the circuit.—The phenomena produced during this phase are often negligible, at least with mechanical interrupters, and in any case the rigorous mathematical treatment offers but little which is of interest. Nevertheless, in order to give an idea of the magnitude of the effects produced, we will take a simple case, one in which the secondary action, $M \frac{di}{dt}$, is negligible; the equation (1) then becomes:

$$RI + L \frac{dI}{dt} = E, \quad (3)$$

since, at the moment of closing, the condenser is short circuited, which corresponds to an infinite capacity. From this equation the value of I in terms of time may be deduced:

$$I = \frac{E}{R} \left(1 - e^{-\frac{Rt}{L}} \right), \quad (4)$$

wherein e is the base of the Naperian logarithms. The curves, I_1 , I_2 and I_3 , of Fig. 9, represent the current as a function of the time for different values of self-induction in the circuit.

The current, I , does not immediately follow Ohm's law, $\frac{E}{R} = I$ —not until the curve has become asymptotic to a straight line whose ordinate is equal to $\frac{E}{R}$. Other

things being equal, the establishment of this state requires a longer time according as the time constant, $\frac{L}{R}$, of the circuit is greater. The name time constant is given to this factor because its dimension in the c.g.s. system of units is that of time; it is also possible to give a physical meaning to this expression: it is the time at the end of which the current has attained 0.633 of the value at which it follows Ohm's law.

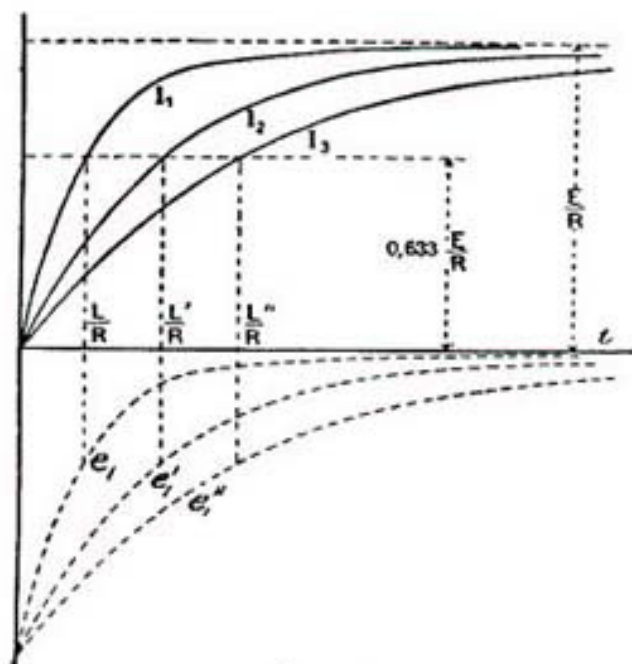

FIG. 9.

By neglecting the action of the secondary, it is always possible to calculate the e.m.f.s. produced in the two circuits by the variation of I during the period of establishment of the current. We have seen that the value of these e.m.f.s. is represented by $-M \frac{dI}{dt}$ and $-L \frac{dI}{dt}$; therefore, in the secondary:

$$e_2 = -M I_{max} \frac{K}{L} e^{-\frac{Rt}{L}} \quad (5)$$

and in the primary:

$$e_1 = -R I_{max} e^{-\frac{Rt}{L}} \quad (6)$$

These e.m.f.s. are maxima for $t = 0$;

$$e'_2 = -\frac{M}{L} E, \quad (7)$$

$$e'_1 = -R I = -E; \quad (8)$$

They then decrease in value and become zero when Ohm's law comes into force, that is, when the current is completely established; the form of the curves, e'_1 , e'_2 , and e''_1 , shown in Fig. 9, illustrate this.

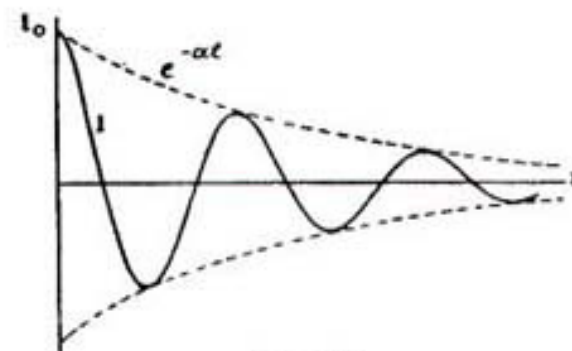

FIG. 10.

5. **Opening the Circuit.**—The opening of the circuit is the most important phase for all coils. Experiments show, and calculations prove, that this phase is much shorter than that of closing; therefore the variation in value of the current, I , being much more rapid, much higher e.m.f.s. are produced and sparks will jump across between the secondary terminals or between the points where the break is made.

We can only calculate that which takes place when the difference of potential, e_2 , between the terminals, 1 and 2, of the secondary, is too low to produce sparks. At the moment when the spark strikes across, the phenomena undergoes a very rapid change, there is a release of energy,

then the phenomena continues, but with a greatly reduced amplitude and it is often complicated by perturbations caused by the spark itself.

The first important theoretical essay was written by

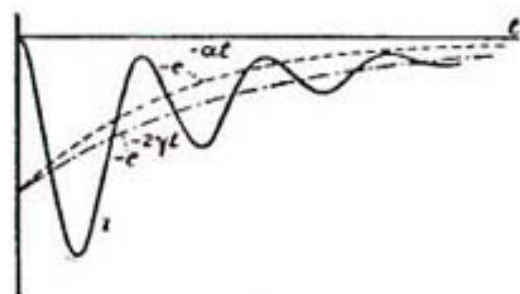

FIG. 11.

Prof. R. Colley and published in 1891 (B. No. 25). The formulas given by Colley are too complex to be used in practice, but we will draw interesting conclusions from them as we proceed. Let it suffice for the moment to say that

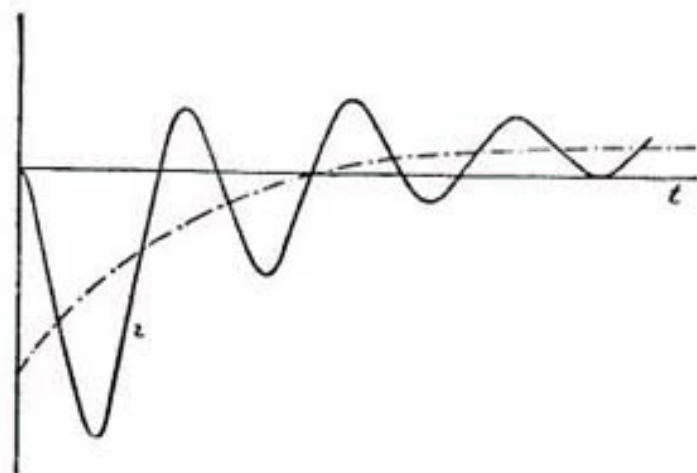

FIG. 12.

Colley treats the primary circuit alone; the same circuit with a condenser (Fig. 10); the secondary on short-circuit and the secondary closed through a condenser (Figs. 11, 12 and 13). Expressed graphically these equations give the curves of the primary current, I , and the secondary

current, i , shown herewith. The equations themselves are given in the bibliography (B. No. 25).

Three years later the author published a theoretical essay (B. No. 28), which was greatly simplified by totally neglecting the reaction of the secondary upon the primary, that is, by solving equation (1) after eliminating the factor, $M \frac{di}{dt}$, and considering the secondary e.m.f. as reduced to $-M \frac{dI}{dt}$. The solution of this equation (1) thus

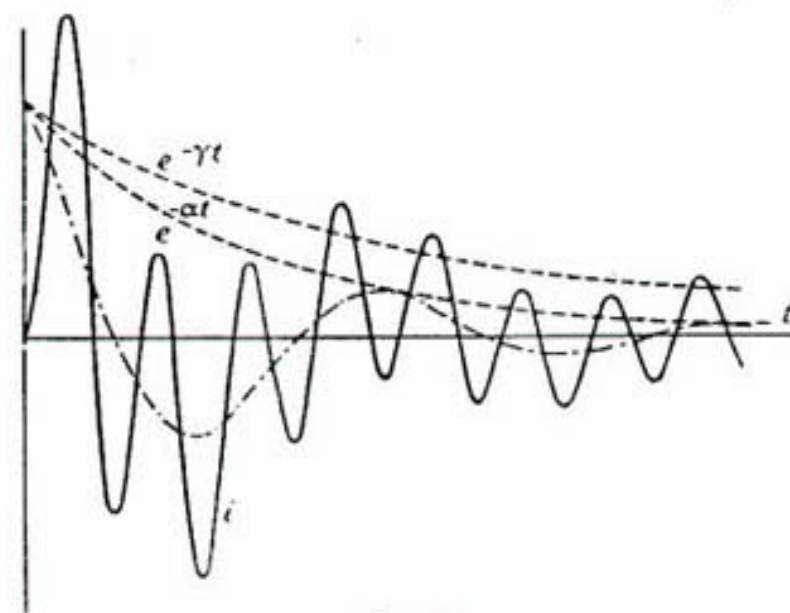

FIG. 13.

reduced, leads to a differential equation of the second order, which has three solutions, according to the value of the resistance, R , in the circuit; namely when,

$$R^2 > 4 \frac{L}{C}.$$

Assuming the values of R , L and C , which generally occur in practice:

$$R^2 < 4 \frac{L}{C}.$$

and the current is expressed thus:

$$I = I_{max} e^{-\alpha t} \left(\cos \beta t - \frac{\alpha}{\beta} \sin \beta t \right), \quad (9)$$

$$\alpha = \frac{R}{2L}$$

$$\beta = \sqrt{\frac{1}{LC} - \frac{R^2}{4L^2}}$$

which was found by Colley. The current is oscillatory and damped (Fig. 10); its period of oscillation, T , is:

$$T = \frac{2\pi}{\beta} = \frac{2\pi}{\sqrt{\frac{1}{LC} - \frac{R^2}{4L^2}}}; \quad (10)$$

the damping coefficient is equal to α .

If the real known values of the coefficients, R , L and C , are substituted in equation (9), it is seen that the value of α is so small that it may be neglected for the first oscillation, and β reduces to

$$\beta = \frac{1}{\sqrt{LC}}$$

The equation (9) then becomes that of a simple alternating current having a period

$$T = 2\pi \sqrt{LC}, \quad (11)$$

and the current may be represented by

$$I = I_{max} \cos \frac{t}{\sqrt{LC}} \quad (12)$$

If, during the first oscillation, the current has the value

given by equation (12), the generated e.m.fs. will be proportional to:

$$-\frac{dI}{dt} = I_{max} \frac{1}{\sqrt{LC}} \sin \frac{t}{\sqrt{LC}}$$

In the time, $t = \frac{T}{4}$, they will attain their maximum values,

$$I_{max} \frac{1}{\sqrt{LC}}$$

it can then be said that these e.m.fs., e'_2 and e'_1 , which are produced by breaking the circuit, approach the limits

$$e'_2 = \frac{M}{\sqrt{LC}} I_{max}, \quad (13)$$

$$e'_1 = \sqrt{\frac{L}{C}} I_{max}, \quad (14)$$

which are in inverse ratio to the periods of oscillations, T , and may also be written,

$$e'_2 = \frac{2\pi M}{T} I_{max}, \quad (15)$$

$$e'_1 = \frac{2\pi L}{T} I_{max}, \quad (16)$$

In the case of a coil with a closed magnetic circuit, where the primary and secondary circuits are at equal distances from the core and so placed that all the flux set up in one will thread the other; the coefficients of self-induction may be represented in the following manner—representing the number of primary turns by n_1 and the number of secondary

turns by n_2 and a coefficient which depends upon the dimensions of the coil by A . Then:

$$L = A n_1^2, \quad (17)$$

$$l = A n_2^2, \quad (18)$$

$$M = A n_1 n_2. \quad (19)$$

When the magnetic circuit is open, and the two windings are superposed instead of being interlaced, there will be magnetic leakage and a part of the flux set up by one circuit will not thread the other. In this case values must be given to the coefficient, A , which differ from those used in equations (17), (18), (19); as first approximation we will assume that these formulas are exact and we have,

$$M = \sqrt{Ll}. \quad (20)$$

This value substituted in (13) gives the formula developed by Walter (B. No.-33),

$$e_2'' = \sqrt{\frac{l}{C}} I_{max}. \quad (21)$$

From equation (13) the following conclusions may be drawn:

1. The secondary e.m.f. is proportional to the primary current value at the moment of rupture.
2. The secondary e.m.f. is inversely proportional to the square root of the primary capacity.

The ratio of the primary and secondary e.m.fs., e_1'' and e_2'' , is,

$$\frac{e_2''}{e_1''} = \frac{M}{L} = \sqrt{\frac{l}{L}} = \frac{n_2}{n_1},$$

that is,

3. The ratio of the e.m.fs. is equal to the ratio of transformation of the coil.

This last conclusion will make it clear later, when the practical values of the transformation ratio of coils are

known, why it is necessary to take such great precautions in insulating the primary circuit and the condenser.

6. **The Complete Period.**—In comparing the equations, (7) and (8) with (13) and (14), we see that at the closing of the circuit, e_1' cannot be greater than E ,* while at the opening of the circuit, e_1'' , may have a very high value:

$$\frac{e_1''}{e_1'} = \frac{1}{R} \sqrt{\frac{L}{C}}.$$

The ratio of the secondary e.m.fs. is the same,

$$\frac{e_2''}{e_2'} = \frac{1}{R} \sqrt{\frac{l}{C}}.$$

It is known that in practice R^2 is negligible in comparison with $\frac{L}{C}$, therefore the ratios, $\frac{e_1''}{e_1'} = \frac{e_2''}{e_2'}$, have very large values.

This comparison of e_1'' and e_2'' explains the well known fact that a galvanometer, connected in the secondary circuit of an induction coil, indicates a unidirectional current as soon as a spark of sufficient length strikes across the secondary terminals, but rests at zero as long as the secondary is on short-circuit. In the first case the e.m.f. at closing is not sufficiently high to force a spark across the terminals, the spark produced by opening the circuit is the only one which strikes across. In the second case the two currents,

* The observation of the current due to self-induction at the moment of closing the circuit is rendered extremely difficult by the fact that its potential can never exceed that of the source. In order to be able to detect it a voltaic pile having an internal resistance, r , which is great in comparison to the coil resistance, R , must be used; or a non-inductive resistance can be connected in the circuit, under these conditions the potential difference at the coil terminals, measured with a voltmeter, is equal to E at the beginning, and falls immediately to

$$E \frac{R}{R+r};$$

produced respectively by opening and closing the circuit, can exist in the circuit. The value of the current, i , produced in the secondary is

$$i = \frac{\left(-M \frac{dI}{dt} + l \frac{di}{dt}\right)}{r};$$

the quantity of electricity, which corresponds to the current variation from 0 to I or from I to 0, is

$$q = \int_0^I i dt = \frac{-M}{r} \int_0^I dI,$$

when the time interval, t , is long enough so that $i_t = i_0 = 0$; this quantity is constant no matter what the wave-form of the current may be, providing the resistance, r , is a constant; this however can only be true when the secondary is entirely closed through metallic resistances, and there are no sparks or equivalent phenomena. The quantities of electricity produced by opening and closing of the circuit respectively are then equal in value and opposite in sign, and when the current interruptions take place in rapid succession their resultant action upon the galvanometer is zero. Therefore the complete period of an induction coil, which produces oscillatory discharges, is made up of the period of closed primary circuit, during which the generated e.m.fs. cannot exceed E and $\frac{M}{L}E$, and the period of

open primary circuit. The rupture takes time, but generally it represents only a fraction of the time lost.

The value of the e.m.fs. produced by the rupture of the current depends upon the value of the current, I_r , at the moment of rupture; according to the length of the time the circuit is closed, I_r approaches more or less the limiting value

$$I_{max} = \frac{E}{R}.$$

In cases where the closed-circuit period is too short to allow the current to attain its maximum value, I_r must be substituted for I_{max} in equations (9), (12), (13), (14) and (21).

When a spark strikes across the secondary terminals, the quantity of electricity produced by closing the circuit can be zero, because at this moment the resistance, r , may be considered infinite. This, however, is not true with cathode tubes, the difference between the currents produced respectively by closing and opening the circuit is

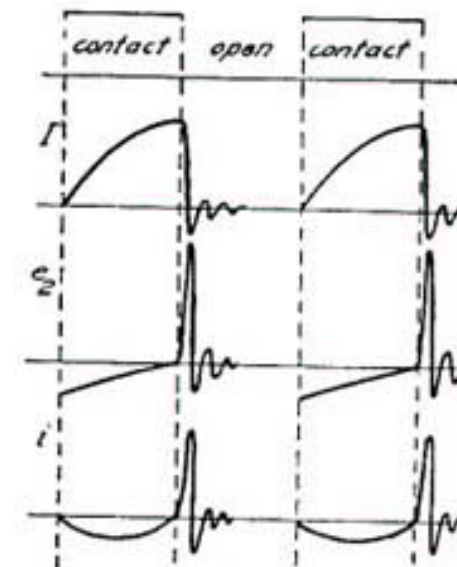

FIG. 14.

still very great, but nevertheless, in some cases it is necessary to take measures to guard against the effect of the current produced by closing the circuit.

7. Induction coil without condenser, secondary closed through non-inductive resistance.—This case very nearly corresponds to that of coils used in electrotherapeutics. The period during which the current is established is exactly like that discussed above in 6. At the moment of rupture no calculation can be made, because the phenomenon depends upon numerous actions which as yet are but little understood. As soon as the primary circuit is

ever, this is not the case, for experiment shows an inflexion, B , which depends upon the type of coil and the sort of interrupter employed (B. No. 39).

The length of the observed spark-gap (striking distance) should vary in inverse ratio with the square root of the capacity, C , however, it is known that the gap is very short for both zero values and very large values of capacity, and

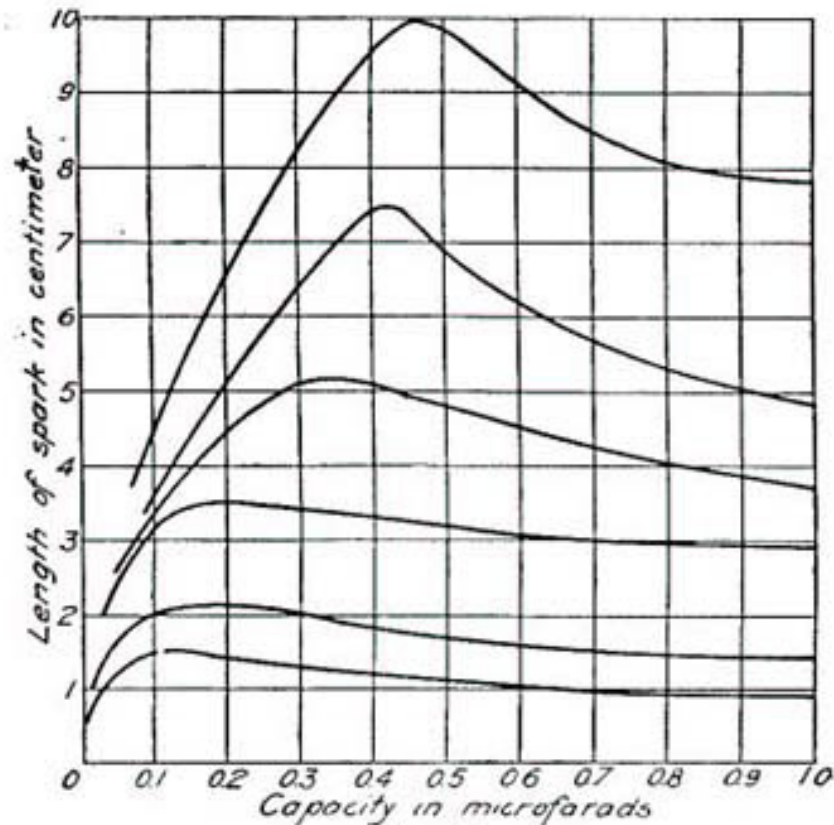

FIG. 18.

therefore there must be some particular value with which the best results will be obtained. The existence of this critical value of capacity, which was known to all practitioners, was put in evidence by the experiments of Mizuno (B. No. 41).

The curves shown in Fig. 18, which represent a part of Mizuno's experiments, show that the critical value of capacity varies with the initial, primary, current value, I_{max} .

As soon as the critical value is passed, the curve follows the theoretical law (13) quite closely; this has been proven by Johnson (B. No. 70) and others.

The ratio of the e.m.fs. generated in the primary and secondary respectively has been checked and verified (B. Nos. 28, 32, 39, 74, 84), but it presents an anomaly which will be explained later.

Experiment shows that in the observed oscillations of the primary current the logarithmic decrement, α , equation (9), is always larger than the value obtained by calculation. Furthermore the ratio of the amplitudes of the first

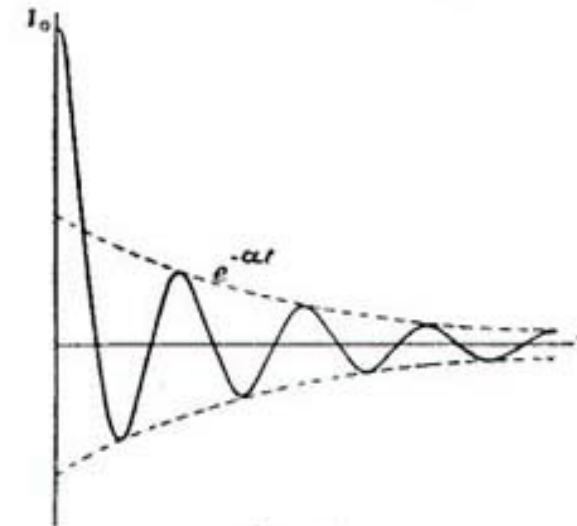

FIG. 19.

two semi-oscillations is generally much greater than that of the following ones (Fig. 19).

These anomalies have the following causes: the primary and secondary sparks; the capacity of the secondary and the presence of iron. These will now be examined separately and in detail.

9. **The Rupture or Break Spark.**—The theory assumes that no spark is formed at the interrupters when the circuit is broken, however this spark exists and varies in strength with the length of the secondary spark—being a maximum, other things remaining equal, when there is no secondary spark, *i.e.*, when the secondary is open. Furthermore,

the spark diminishes as the capacity of the condenser is increased; at least this is true with interrupters which are slow enough to permit a distinct separation of the closing and the opening of the circuit.

Does the spark at the break behave like a variable or constant resistance connected in parallel with the breaking contacts? Arons (B. No. 34) tried to calculate the effect of a resistance varying from R_0 to ∞ , without taking the condenser into account, and Mizuno (B. No. 76) assumed a constant resistance in parallel with the condenser; however neither of these hypotheses when worked out solved the problem.

By considering the break-spark as a disruptive phenomenon, *i.e.*, of very short duration in comparison with the period of oscillation of the primary current, it will be seen that the phenomenon will become very easy to explain, but, unfortunately, almost impossible to calculate.

In that which follows, the secondary reaction will be neglected and it will be assumed that there is no damping effect.

First, the distribution of energy in the coil will be considered. As long as the primary is closed, the energy is furnished by the source and the current is limited only by the resistance of the circuit. One part of the energy is dissipated in heat, while the other is stored in the circuit and released when the circuit is broken. This latter, equal

to $\frac{L I_{max}^2}{2}$, is all that concerns us, because it is that which causes the sparks. If, as we have assumed, there is no damping effect, the stored energy should be constant and, as the kinetic energy, $\frac{L I^2}{2}$, diminishes, because of the dim-

inution in the current which results from the oscillation, the energy in the condenser should increase; we should always have

$$\frac{L I_{max}^2}{2} = \frac{C e_1^2}{2} + \frac{L I^2}{2};$$

this equation is graphically represented in Fig. 20. It is seen that when the current, I , is zero, the total energy is held in the condenser.

There is a known and constant ratio between the primary and secondary e.m.fs.; consequently, the curves which are discussed below represent either e.m.f. by a simple change in the scale of the ordinates.

From the moment of rupture of the current, the e.m.f. of self-induction, e_1 , increases from zero, at first rapidly,

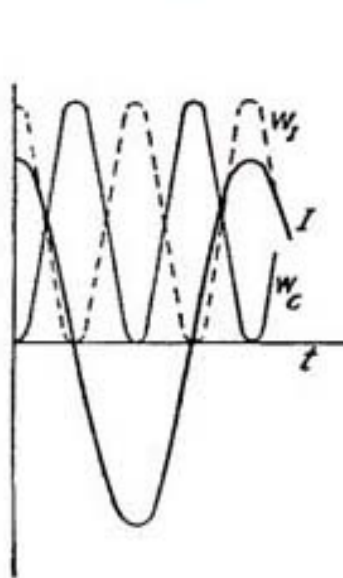

FIG. 20.

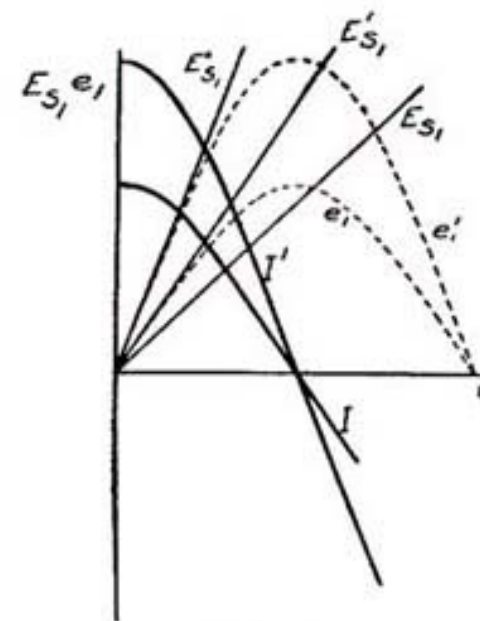

FIG. 21.

then reaches a maximum for $t = \frac{T}{4}$ (Fig. 21). At the moment of rupture the distance between the contact points is, at first, zero. Now we know that for very short distances the striking voltage is proportional to the distance; therefore if the speed is such that the striking voltage, E_{s1} , increases at a lower rate than e_1 , a spark will form at the interrupter, start a small arc and thereby prevent the rapid variation of the current, I ; according to this hypothesis, it is necessary, in order to prevent the rupture spark, to have the speed of the interrupter above

a certain value, so that the line of striking voltage, E_{s1}' , is at least tangent to the curve, e_1 (Fig. 21). This is the theory recently proposed by Ives (B. No. 81). This theory is immediately destroyed by the following objection: If the initial current, I_{max} , is increased, the curve, e_1 , will become e_1' and cut the line, E_{s1}' , so that the result of increasing the current without changing the speed of the interrupter should be to diminish the length of the secondary spark.

Assuming now, that line, E_{s1} , instead of passing through the origin, passes above it (Fig. 22), it is instantly seen

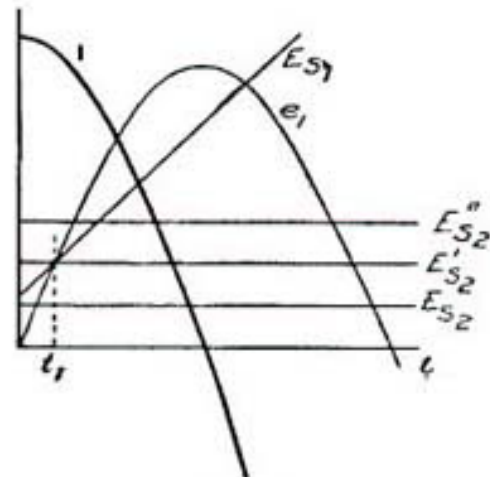

FIG. 22.

that, up to the time, t_1 , the e.m.f., e_1 , is less than the striking voltage, E_{s1} . The break-spark occurs at this instant; it lags behind the geometrical rupture of the circuit. If the lines, E_{s2} , represent, to a convenient scale, the secondary striking voltage, it is seen that the length of the sparks cannot be greater than E_{s2}' . In fact, if the striking voltage of the secondary is E_{s2}'' , it is seen that it can not be attained until the striking voltage of the interrupter has been exceeded, the interrupter spark has, therefore, already occurred and a part of the available energy been dissipated. In this case there could be no secondary spark. The ordinates of the lines, E_{s1} and E_{s2} , represent-

ing the striking voltages may also be considered as representing the resistance to the sparks in the respective circuits. This hypothesis furnishes the following results: the spark is produced in the circuit where the relative resistance is weaker.

This theory allows us to explain the critical capacity: if we vary the capacity, C , alone, the calculated e.m.f. will be represented by the curves, e_1' , e_1'' , shown in Fig. 23, the maximum amplitudes are inversely proportional to the period of oscillation, according to equation (15). If the curve of the striking voltage is represented by the straight line, E_{s1} , the primary spark will occur at the moment when the line, E_{s1} , crosses the curve of e_1 ;

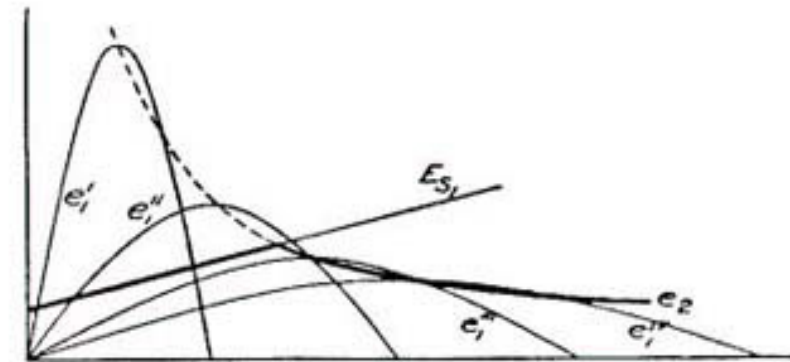

FIG. 23.

if the secondary spark requires a voltage less than $\frac{M}{L}E_{s1}$,

the spark will occur in such a manner that the maximum e.m.f. available at the secondary terminals, is represented by the curve, e_2 , which is tangent to E_{s1} until it cuts e_1 , and decreases according to the theoretical equation (13); i.e., it passes through the vertices of the e_1 curves. The similarity between the curve, e_2 , and those in Fig. 18 should be noted.

We must now complete the theory by considering that which takes place when sparks are formed at the interrupter. At this moment the condenser is charged with all the energy lost in the coil, the spark suddenly dis-

charges it,* the difference of potential becomes zero, and we have the conditions as expressed by equation (1) and

$$E = RI + L \frac{dI}{dt},$$

or

$$L \frac{dI}{dt} = E - RI;$$

i.e., the value of the e.m.f. of self-induction becomes negligible in comparison with that which it had before. There-

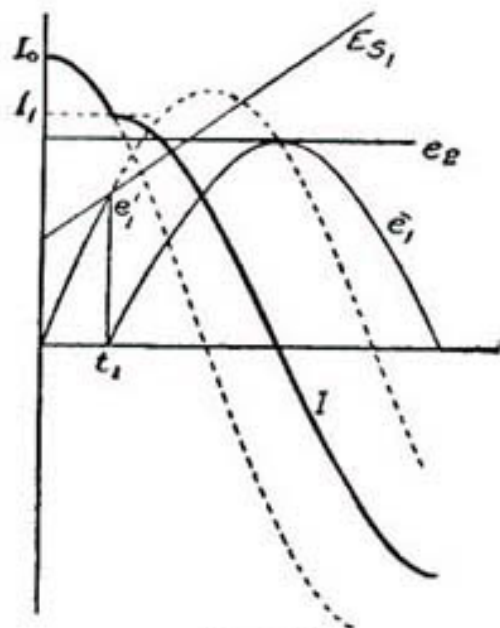

FIG. 24.

fore we can say that the current, I , becomes constant for an infinitely short time and that it starts from this value, I_1 , to begin an oscillation of lesser amplitude (Fig. 24). The e.m.f. of self-induction increased to e_1' and fell back to zero to start again.

If the second part of the curve, e_1 , does not cut the line,

* In reality the discharge of the condenser is not instantaneous, it is oscillatory, intermittent or damped, but the total duration of the phenomenon is so short in comparison with the oscillation of the coil that they may be neglected.

E_{s1} , there will be no spark at the interrupter and the e.m.f. of self-induction will be generated according to the theory and the secondary e.m.f. may attain the value

$$e_{2max} = \frac{M}{L} e_{1max}.$$

If e_1 meets the line, E_{s1} , again another spark will be produced and another "shifting" point will occur in the current curve, I . Thus it is possible that a number of sparks be produced before the curve, e_1 , gets beyond the line, E_{s1} .

Regardless of the number of sparks formed at the

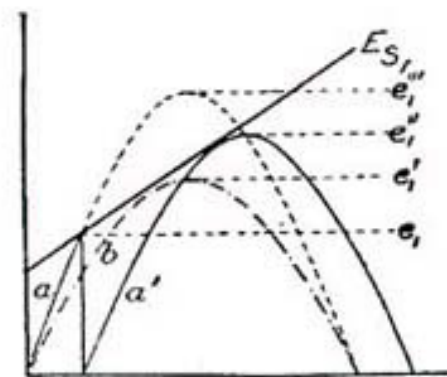

FIG. 25.

breaking contacts, everything takes place as though the initial current value, I_1 , was that at which the last spark was produced, and not until this moment, t_1 , is passed can the mathematical theory be applied.

We can now understand how it is that an increase in current value, I_{max} , will increase the length of the sparks. Let b (Fig. 25) be the curve of e.m.f. generated for a certain current value and striking voltage, E_{s1} ; the maximum of b is e_1' . By increasing the current value the curve, a , is obtained, which meets E_{s1} in e_1 ; the rupture spark is produced and the e.m.f. drops to zero, to start another oscillation, a' , the maximum amplitude of which is e_1'' , which is greater than e_1' . Thus, in spite of the rupture spark

an e.m.f. is produced which is greater than that in the first case.

This theory which the writer proposed in 1900 (B. No. 67) will serve us in that which follows.

10. **Proof of the theory of the least resistance to the spark.**—The above theory requires that the rupture spark should lag behind the mechanical rupture of the circuit. Observation of this spark with an oscillating mirror, driven by the interrupter, shows that this is really the case and that the amount of the lag varies with the coefficient of self-induction, the capacity and the current value.

The ordinate at the origin of the curve, E_{s1} , exists, because the origin of the time, t , is taken at the moment when the e.m.f. starts from zero, and not at the moment when the mechanical rupture of the circuit occurs. The lag between these two phenomena can be explained by several hypotheses. The ones which seem the most plausible are given below; they share perhaps equally in the result.

At the moment of rupture the two contact points are separated by an infinitely small distance; therefore at the first instant there exists an infinite capacity between the contacts which, however, is very rapidly reduced to zero. This capacity created by the rupture retards the e.m.f.s., which develop at the origin, slower than the theory would indicate.

It is also possible to concede that the capacity of the secondary causes the variation in the difference of potential not to follow the simple sine law and that Colley's formula (S) (B. No. 25) is correct. The curve of the difference of potential is the sum of the oscillations, 1 and 2, of the primary and secondary (Fig. 26); the maximum of $\frac{dE}{dt}$ is not at the origin; therefore the curve, E , does not

meet the curve, E_{s1} , until a moment later.

Finally, it is well known that the actual theory requires

that there be a minimum difference of potential at which a spark can pass across the terminals; this minimum value corresponds to the pressure necessary to break down the dielectric in contact with the terminals. From this it results that the curve of striking voltage does not pass through the origin.

Whatever the real cause of this lag of the rupture spark may be, the fact is, that it exists and must be taken into account.

The existence of "shifting" points in the primary, current curves and the dips in the secondary current curves

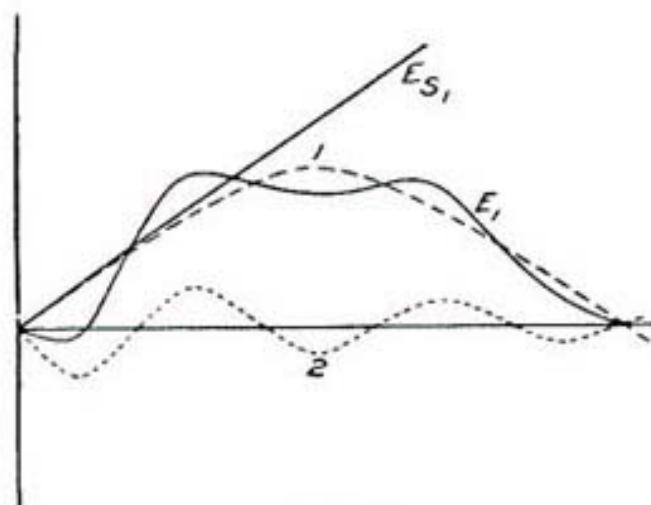

FIG. 26.

are clearly shown by the oscillograph, as given in Figs. 30, 31, and 35. It would occupy too much space to discuss these experimental results at this point. This was done in the periodicals (B. No. 84).

The oscillograph shows that the "shifting" points are not very stable; they vary most often between I_{max} and zero. This is easily understood; the law of the striking voltage is not constant, it depends upon the form and state of the contact surfaces and is modified from one instant to the next by the corroding effect of the sparks.

Still another proof of the existence of these shifting points lies in the following fact: it has been seen that the

damping of the oscillations is regular only after the second semi-oscillation. If the curve drawn through the vertices of the oscillation curve is prolonged it will always pass through the "shifting" point (Fig. 27). Moreover, experiment shows that an increase in the primary capacity which diminishes the e.m.f. of self-induction causes the difference between the first semi-oscillation and those following to disappear (B. No. 84).

As would be expected the nature of the metals, composing the contact point, has an influence upon the result.

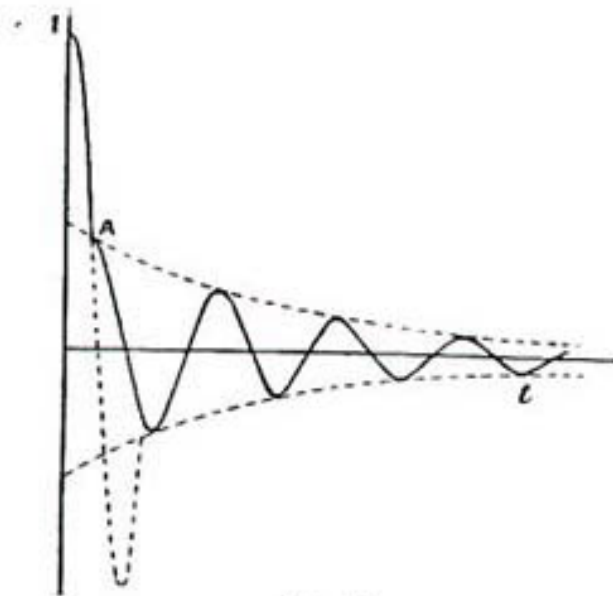

FIG. 27.

Beattie has demonstrated experimentally (B. No. 71) that the critical capacity was smaller with platinum contacts than with other metals. Ives (B. No. 83) found that, with a mercury interrupter, the critical capacity varied according to the polarity of the mercury. These facts are easily explained by the corrosion of the contact surfaces, which varies with the metal and the direction of the current.

The theory leads us to the conclusion that the break should be made as rapidly as possible; Lord Rayleigh showed that breaking the circuit by shooting a bullet

through a wire made it possible to attain long secondary sparks without a condenser in the primary (B. No. 79). Practically the rapidity is limited. With mechanical interrupters having solid contacts, the rapidity is limited by the imperfection of the contacts; nevertheless much progress has been made in obviating this difficulty. With the mercury interrupters there is a limiting speed above which there is no interruption, or at least the initial rapidity of interruption attains a limit; which is probably due to the fact that the column of mercury breaks by its own weight. This explains why mercury interrupters are less well adapted to small coils than to large ones; the former have a shorter period and require greater initial rapidity.

A paradoxical consequence upon which our theory is based, is that the spark at rupture cannot be avoided; the secondary spark is often longer and more regular with a fat flaming spark at the point of rupture than when the latter is less apparent. It is easily understood that if several small sparks form at the interrupter, their aspect is different from that of a single discharge of the primary condenser; but, since the final result, *i.e.*, the length of the secondary spark depends upon the value of the current, I , at the moment of rupture of the last spark, there exists no definite relation between the two sparks.

The multiple primary spark shows that it could be advantageous to increase the coefficient of self-induction of the primary, all other things remaining equal, thus increasing the capacity of the coil to store energy after the discharge of the condenser. Since the proper increase in the coefficient of self-induction cannot be calculated it is best to use a coil in which the primary contains an adjustable inductive reactance.

11. **The role of secondary capacity.**—The secondary capacity is not situated at the secondary terminals; it is distributed, in a more or less regular manner, throughout the entire secondary circuit. The capacity of the secondary circuit varies with the form of the winding.

Fig. 28 represents schematically the section of a coil; the little circles represent the section of the wires, and the arrows show the direction of the e.m.fs. It is evident that there exists between the points, *a* and *b*, an e.m.f.; the value of which is great or small according as there are many or few turns of wire connected between the two points.

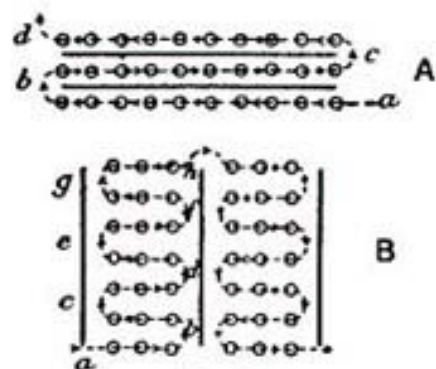

FIG. 28.

If in each turn there is generated an e.m.f., e , and if we consider two consecutive layers, each formed of N turns, the difference of potential between two turns which are adjacent but belong to different layers is

$$2ne,$$

wherein n is the number of turns counting from the point of junction of the two layers to the turn in question; the quantity of electricity stored is

$$\int_0^N ce 2n dn = N^2 ce,$$

wherein c is the capacity which exists between each turn and the corresponding turn of the other layer.

Assume that the same number of turns, $2N$, are distributed in $2m$ layers, each double layer would store

$$\frac{N^2 ce}{m^2},$$

and the whole would store m times that, or

$$\frac{N^2 ce}{m}.$$

The difference of potential, or e.m.f., at the secondary terminals in both cases would be

$$2Ne.$$

The apparent capacities are respectively

$$\frac{Nc}{2} \text{ and } \frac{Nc}{2m},$$

that is, the system with $2m$ layers would give m -times less capacity.

The winding shown at *A* (Fig. 28) is made in layers, while the one shown at *B* is made in sections. It should be noted that in the latter winding it is necessary to add to the capacity as found above, that which exists between the adjacent sections. The real value and calculation of the secondary capacity is one of the most obscure points in the theory; the demonstration given above is simply a crude approximation.*

Whatever the distribution of the capacity of the secondary winding may be, it is not always negligible; to it are due the electrical oscillations observed by Mouton (B. No. 2) in a coil using no condenser in the primary circuit. It is also to the capacity of the secondary winding that the oscillations in the primary are due when the secondary winding is short-circuited, since otherwise the energy

*The turns situated in the interior of the winding should not take any charge, because the quantities of electricity with which the neighboring turns become charged through electrostatic induction are equal and opposite in sign. The turns upon the exterior surface of the winding not being completely surrounded become charged to a greater or less degree. Therefore, it seems that the capacity of a coil is simply that of the turns which form the exterior surface.

dissipated in the secondary would completely damp the primary oscillations.

What is the capacity of the secondary and within what limits should it be reckoned with? Opinions on this subject differ greatly: Walter (B. No. 43) estimates the capacity of his coil as 1.1×10^{-6} microfarads, and according to Oberbeck the capacity of the same coil would be 450×10^{-6} microfarads.

The value given by Walter appears to be nearer to the true capacity of the secondary winding for ordinary coils. If the first value is assumed to be correct, it is seen that the duration of the secondary oscillation is much shorter than that of the primary; therefore, as first approximation, this capacity can be neglected.

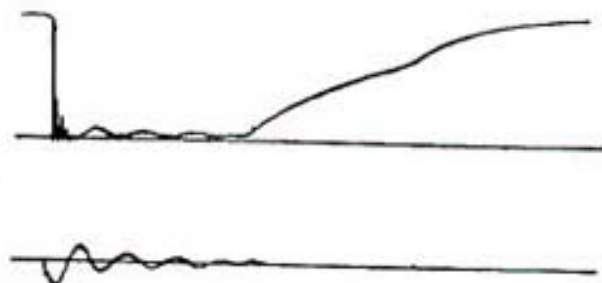

FIG. 29.

One of the most probable effects of the capacity of the secondary winding is to cause phase differences between different parts of the circuit; this effect, which should not be confused with stationary waves of which we will speak farther on, may diminish the e.m.f. between the secondary terminals (B. No. 82).

When capacity is connected to the secondary terminals a change is produced in the operating characteristics; the predominance of secondary oscillations is quickly obtained and we enter the case covered by the equations of Colley—the superposition of short primary oscillations upon the longer secondary oscillations (Fig. 29). The secondary oscillations are less damped than those of the primary, and do not entirely die out during the interval that the

circuit is open; they have sufficient amplitude, at the moment of the next "make", to produce an e.m.f. in the primary, which sometimes can produce a large negative value of current (Fig. 30). If the open-circuit lasts long enough, this action disappears, but the capacity of the secondary winding causes other primary oscillations, which do not always change the sign of the current (Fig. 31).

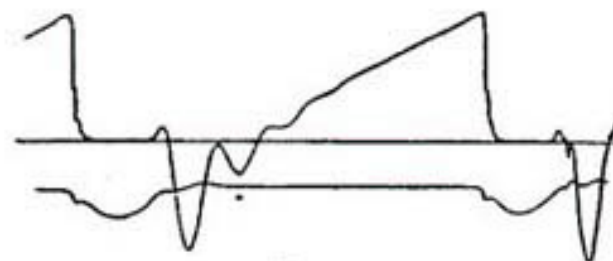

FIG. 30.

12. **Resonance.**—Resonance has often been invoked to explain the optimum capacity and certain obscure phenomena; does it exist and under what circumstances should we have recourse to it?

Resonance as ordinarily looked at does not exist; in fact, considering a resonant circuit, consisting of an in-

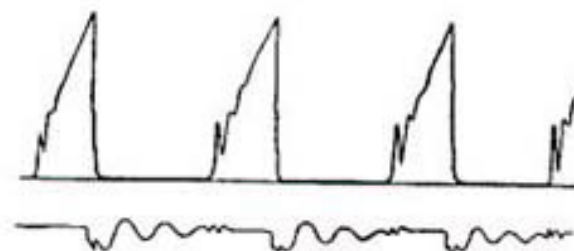

FIG. 31.

ductive reactance and condensive reactance connected to an alternator, it is seen that the current in the circuit and e.m.f. across the condenser have small values so long as resonance is not attained; on the other hand, when the resonance is perfect the current value becomes a maximum and the e.m.f. across the condenser may greatly exceed

that of the alternator; if the power absorbed is measured it will also be found to be a maximum at this moment.

With an induction coil the phenomenon is different; it should be borne in mind that the interesting phase is that of the "break"; at this moment there is no complete connection with the primary source, the available energy is limited to $\frac{L I^2}{2}$, which is stored in the magnetic field at the moment of rupture. Therefore, no matter what happens, the resonance cannot increase the power demanded of the source; one of the most important factors of the phenomenon disappears; of course, the two phases, make and "break", are considered as distinctly separate and without effect one upon the other.

A comparison between the induction coil and the tuning-fork immediately suggests itself; both, after having been put in vibration, *i.e.*, after having received a certain quantity of energy are abandoned to themselves. It is well known that a tuning-fork will cause a resonator to vibrate, the better the attunement the stronger the resonant vibrations; as soon as the attunement is not attained the resonator becomes silent. Is an analogous effect obtained with induction coils? That which we know of the mathematical theory demonstrates the contrary. In fact, taking equations (S) of Colley (B. No. 25), and assuming a negligible damping of the oscillations, it is seen that the secondary e.m.f., E_2 , decreases constantly when the secondary capacity, c , is increased. For $c = 0$,

$$E_2 = I_{max} \sqrt{\frac{L}{c}}$$

Resonance exists when $c = \frac{LC}{L}$,

$$E_2 = \frac{1}{2} I_{max} \sqrt{\frac{L}{c}} = \frac{1}{2} I_{max} \sqrt{\frac{L}{C}}$$

When C_2 is very large compared with $\frac{L_1 C_1}{L_2}$,

$$E_2 = I_{max} \sqrt{\frac{L}{c}}$$

The formulas of Colley appear here to be incorrect, because considering the total available energy, it should always be $\frac{L_1 I_{max}^2}{2}$; the equations for the two limits, $C_2 = 0$ and $C_2 = \infty$, agree with this assumption, but for the condition of resonance

$$\frac{c E_2^2}{2} + \frac{C E_1^2}{2} = \frac{L I_{max}^2}{4}$$

This discrepancy comes from the fact that Colley, like every one else, has neglected a certain number of factors in order to avoid unnecessary complication in the formulas, but the result shows that one should not generalize results without careful consideration.

If, neglecting the $I^2 R$ losses, the energy stored in the magnetic field is taken as a base for the calculations

$$\frac{c E_2^2}{2} + \frac{C E_1^2}{2} = \frac{L I_{max}^2}{2},$$

from which

$$E_1 = \frac{L I_{max}}{\sqrt{cL + CL}}$$

$$E_2 = \frac{M I_{max}}{\sqrt{cL + CL}}$$

For the condition of resonance

$$E_1 = \frac{L I_{max}}{\sqrt{2LC}}$$

$$E_2 = \frac{M I_{max}}{\sqrt{2LC}}$$

The equations for the limits, $c = 0$ and $c = \infty$ being, the same as the ones found above.*

The law of the variation of E_2 with the secondary capacity is shown in Fig. 32 for both hypotheses: it is seen that resonance cannot increase the secondary e.m.f. Nevertheless, experiments show that it is possible to increase the length of the spark, when a large capacity is added to the secondary and the primary condenser is adjusted to be in the neighborhood of resonance: $CL = cL$. This pseudo-resonance may be approximately explained by the theory of less resistance to the spark. When the secondary capacity is not negligible, it has been seen that the e.m.fs. of induction are the sum of two functions of different periods, the oscillations in the secondary e.m.f. curve (Fig. 26) have more chances of meeting the curve of striking voltage, E_{st} , than the simple curve, 1, which is obtained with resonance.

It can be assumed that a coil, in which the two circuits are in resonance, is the seat of stationary waves with a maximum pressure at the extremities and a maximum

*It is possible to prove that the ratio of the e.m.fs. at the terminals of the two capacities is constant, when there is no magnetic leakage. In fact, neglecting the e.m.f. of the source and the resistance of the circuits, we can write

$$E_1 = L \frac{di}{dt} + M \frac{dI}{dt}, \quad I = -C \frac{dE_1}{dt},$$

$$E_2 = l \frac{dI}{dt} + M \frac{di}{dt}, \quad i = -c \frac{dE_2}{dt},$$

from which

$$\frac{E_1}{M} - \frac{E_2}{l} = \frac{M^2 - Ll}{Ml} C \frac{d^2 E_1}{dt^2},$$

and if $M^2 = Ll$

$$\frac{E_2}{E_1} = \frac{l}{M}.$$

The ratio is therefore equal to the ratio of transformation.

current at the middle. It is possible that the value of the current may not be the same in all parts of the secondary circuit, but there is little probability that nodes and antinodes comparable to those observed in Hertzian waves, could be detected. The problem is different: In each turn of the coil there are superposed two e.m.fs.: one is about the same for all turns, produced by the action of the primary, is proportional to $\frac{dI}{dt}$; the other is due to the passage of the wave; it is probable that the e.m.f. of mutual induction frequently overshadows the latter, because it is very difficult to observe a well defined

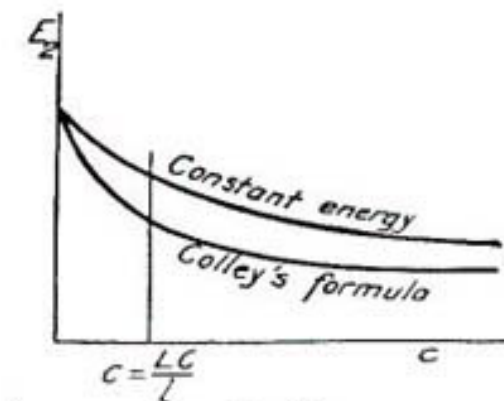

FIG. 32.

variation in the value of the current along the secondary circuit, as long as there are no very high frequency oscillations; in this latter case resonance of the primary and secondary can no longer be attained.

13. **The effect of the core.**—Up to this point we have considered only coils without iron cores. Although it is impossible to represent the action of the iron by adding terms to the general equations, there is no doubt as to the importance of this action, and it is necessary to form an idea of its character and effects.

It is said that the iron core increases the power of the coil as in commercial transformers. There is however an important difference between the two. While in the or-

dinary transformer, the iron, by virtue of its permeability, permits the absorption of more energy from the source and the delivery of more to the secondary; in the induction coil, which is a sort of a "deferred" transformer,* because it stores energy during the period when the circuit is closed and delivers it later when the "break" occurs, the hysteresis plays an important role. If the magnetic circuit is completely closed, the total useful energy is independent of the iron, it increases when the magnetic circuit is opened and afterward decreases; that is, there is a certain proportion between iron and air-gap which gives a maximum useful effect. This fact, which has long been known, was explained by Lord Rayleigh (B. No. 79).

The theory of Lord Rayleigh is as follows: Consider a small straight bar of iron placed in a uniform magnetic field, \mathcal{K}' ; the magnetization of this bar produces at its extremities magnetic masses, which create a field that is opposed to \mathcal{K}' . If the demagnetizing factor is denoted as J , the intensity of magnetization as \mathfrak{J} , the opposing field is $J\mathfrak{J}$, and we have

$$\mathcal{K} = \mathcal{K}' - J\mathfrak{J};$$

that is, the bar is acted upon by an effective field, \mathcal{K} , the value of which is less the greater J . J is a function of the ratio of the diameter of the bar to its length. It is well known that the energy stored in the field, \mathcal{K}' , during magnetization is proportional to

$$W_{\mathcal{K}} = \int \mathcal{K}' d\mathfrak{J} = \int \mathcal{K} d\mathfrak{J} + J \int \mathfrak{J} d\mathfrak{J};$$

if the cycle is complete, the term, $\int \mathcal{K} d\mathfrak{J}$, represents the energy absorbed by hysteresis, therefore there remains as available only

$$J \int \mathfrak{J} d\mathfrak{J} = \frac{J\mathfrak{J}^2}{2}.$$

*The "make" and the "break" are always considered as distinctly separate phenomena.

Consequently, the available energy increases, other things being the same, with the value of the demagnetizing factor, that is, when the ratio of the diameter to the length increases.*

If the core is straight or the magnetic circuit is not completely closed, there will be magnetic leakage and we have

$$M^2 < LI.$$

Lord Rayleigh explained (B. No. 79) how magnetic leakage causes losses of energy; we can show this loss in a different manner.

There are only two cases where the energy in the coil

*It is possible, by applying the theory to two calculable cases, to show that there is a proportion of air-gap and iron in the magnetic circuit which gives a maximum useful effect. The variation of energy in a coil carrying a current, I , is

$$dW = I d\phi,$$

ϕ being the total flux through the coil,

$$\phi = \mathcal{B} A N.$$

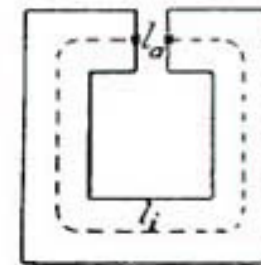

FIG. 33.

The coil having N turns of area A and its length being l , the magnetizing force, \mathcal{K}' , is

$$\mathcal{K}' = \frac{4\pi N I}{l}.$$

If the coil is sufficiently long,

$$dW = \frac{Al}{4\pi} \mathcal{K}' (d\mathcal{K} + 4\pi d\mathfrak{J}).$$

Now considering a magnetic circuit almost closed (Fig. 33),

is well utilized, namely: When the secondary circuit is closed through a resistance capable of absorbing much energy; or when there is a very large capacity between the secondary terminals. In the first case the calculation of the energy is difficult, but in the second it is easy enough. It is known, from the equations of Colley, that the maximum secondary e.m.f., neglecting the resistance of the circuit, is

$$e_2 = \frac{M I_{max}}{\sqrt{lc}}$$

the energy stored in the secondary is

$$\frac{c e_2^2}{2} = \frac{M^2 I_{max}^2}{2l}$$

denoting the air-gap as l_a and the length of the iron circuit as l_i , assume a uniform flux throughout and apply the classic equation for the magnetic circuit

$$4\pi N I = \mathfrak{B} A \left(\frac{l_i}{\mu A} + \frac{l_a}{A} \right);$$

recalling that

$$\mathfrak{B} = \mu \mathfrak{H} = \mathfrak{H} + 4\pi \mathfrak{J},$$

we have

$$dW = \frac{A l_i}{4\pi} \left[\left(\frac{l_i + l_a}{l_i} \right) \mathfrak{H} d\mathfrak{H} + 16\pi^2 \frac{l_a}{l_i} \mathfrak{J} d\mathfrak{J} + 4\pi \left(\frac{l_i + l_a}{l_i} \right) \mathfrak{H} d\mathfrak{J} + 4\pi \frac{l_a}{l_i} \mathfrak{J} d\mathfrak{H} \right].$$

For the reason indicated above, the factors, $\mathfrak{H} d\mathfrak{J}$ and $\mathfrak{J} d\mathfrak{H}$, should disappear and we have, simplifying,

$$W = \frac{A l_i}{8\pi} \mathfrak{H}^2 \frac{l_i + l_a (\mu^2 - 2\mu + 2)}{(l_i + \mu l_a)^2}.$$

It is seen immediately that if the magnetic circuit were completely closed, $l_a = 0$

$$W = \frac{A l_i}{8\pi} \mathfrak{H}^2,$$

which is the same as if there were no iron in the circuit. On the contrary, if the ratio of l_i to l_a is equal to the permeability μ ,

and, if we assume $L > \frac{M^2}{l}$,

$$\frac{c e_2^2}{2} < \frac{L I_{max}^2}{2},$$

therefore the energy absorbed is less than that available in the secondary.

The theory takes into account the damping of the oscillations, by the resistance of the circuits; experiment shows that the damping effect is always much greater than the theory would call for; there is, therefore, another source of loss.

Study of the oscillations reveals that, the initial amplitude being the same, the ratio of two consecutive oscillations

the available energy is a maximum and equal to

$$W = \frac{A l_i}{8\pi} \mathfrak{H}^2 \frac{\mu}{4}.$$

In order to compare a straight core with a closed magnetic circuit, it suffices to recall that the effective field is

$$\mathfrak{H} = \mathfrak{H}' - \mathfrak{J},$$

while

$$\mathfrak{H} = \mathfrak{H}' - \mathfrak{B} \frac{l_a}{l_i}$$

in the closed magnetic circuit. The two systems are the same when

$$\mathfrak{B} \frac{l_a}{l_i} = \mathfrak{J}.$$

\mathfrak{J} is approximately equal to $\frac{\mathfrak{B}}{4\pi}$; therefore we must have simply

$$\mathfrak{B} = 4\pi \frac{l_a}{l_i} = \frac{4\pi}{\mu}.$$

Experiments show that in cores of coils the permeability, μ , is generally about 50; \mathfrak{J} would be 0.25, which according to what is known of demagnetizing factors, corresponds to a length equal to about ten times the diameter of the core.

The calculation is evidently very approximate, general conclusions should not be drawn from it, because it must be remembered that it rests on the assumption that there is no hysteresis and contains numerous simplifications.

tions, with exception of the first, is independent of the duration of the oscillation; the loss is, therefore, due to a cyclic phenomenon, independent of time, and it is natural to attribute it to the action of the iron.

The action of the iron also makes itself felt when the circuit is closed. The coefficient of self-induction of a

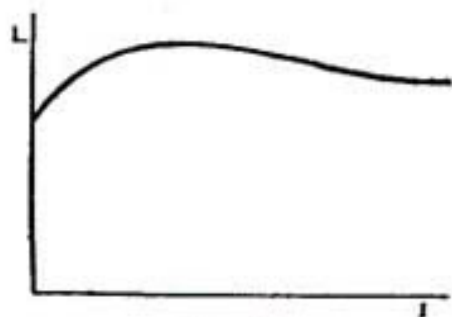

FIG. 34.

coil with an iron core is not constant; it is a function of the value of the current (Fig. 34); it follows the permeability of the iron in such a manner that, if the iron is saturated, the e.m.f. of self-induction, which opposes the establishment of current, descends quicker than would be expected and a curve having a point of inflexion is

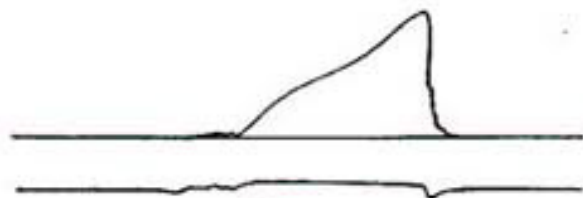

FIG. 35.

obtained; after saturation, the current value increases more rapidly for a certain time, instead of following the theoretical form; this is shown very clearly in Figs. 35, 36 and 37.

The variable permeability of the iron produces still another effect; the magnetizing action which is exercised upon the iron, is the resultant of the action produced by

the two circuits; so that, for a given value of primary current, it is possible to obtain oscillations of different lengths, according to whether there is or is not a current in the secondary circuit. Figs. 31 and 37 show this effect: during the period that the primary circuit is open,

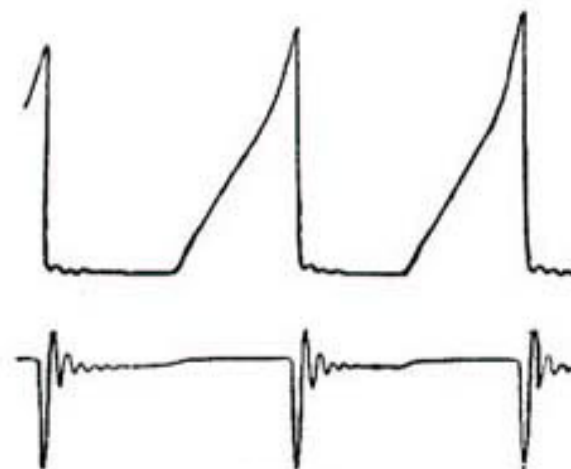

FIG. 36.

there are complex oscillations due to the primary and secondary; the period of these last is given by the lower curve which is proportional to $\frac{d\phi}{dt}$. As soon as the primary is again closed, these oscillations disappear because

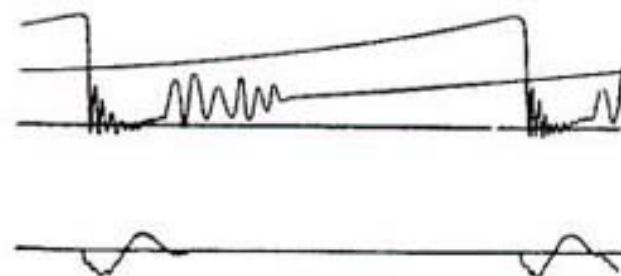

FIG. 37.

the condenser is short-circuited; there remains, therefore, only those oscillations produced by the secondary in the primary; an examination of the curve of "current growth" shows that these become immediately much more rapid; the primary circuit makes a sort of a shield between the

secondary and the core and the latter being scarcely magnetized, the coefficient of self-induction is greatly reduced. The curve, $\frac{d\phi}{dt}$, is nearly suppressed, even though there exists in both circuits oscillations of great amplitude; the cause of this is, that the oscillations in the two circuits have a phase displacement of about 180° and the ampere-turns acting upon the core are about equal and opposite in sign.

14. **Effect of the secondary discharge.**—In order to complete the study of the different elements of the problem, it is necessary to consider that which takes place when there is a discharge in the secondary. All discharges dissipate energy, it can, therefore, be foreseen that the current curves have turning points for the primary sparks as well as for the secondary sparks. Tests with the oscillograph verify this supposition; generally the effect of the secondary spark is to suppress primary oscillations. Figs. 31 and 35 show the curve of the primary current and that of the variation of the flux; in Fig. 35, the secondary capacity is negligible. The curve of rupture shows very plainly two turning points—the first is due very probably to the spark at the contacts and the second to the discharge of the secondary; the location of these two points can be found in the curve, $\frac{d\phi}{dt}$. In Fig. 31, the same coil has its secondary circuit closed through a large capacity; from the curve, $\frac{d\phi}{dt}$, it is seen that the development of the secondary oscillation is first arrested by the spark at the interrupter contacts; then by the discharge. The two sparks, primary and secondary, do not occur at the same instant, therefore the ratio of e.m.f.s. to which they correspond is not the ratio of transformation.

This last result shows that one cannot rely absolutely upon the accuracy of striking voltages determined with the aid of an induction coil, when the e.m.f. measured in

the primary is multiplied by the ratio of transformation. If the secondary capacity is not negligible and there is magnetic leakage, difference in phase between the two currents will be produced and the ratio of transformation will vary quite materially. In this manner the results obtained by Klingelfuss (B. No. 74) can be explained.

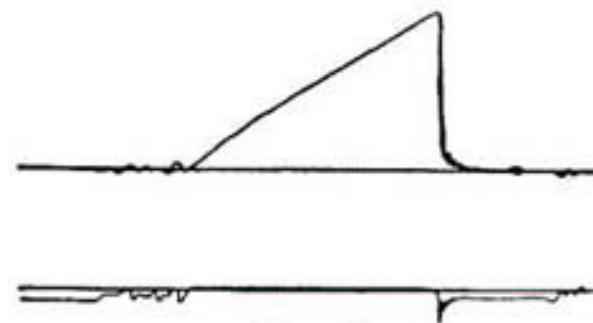

FIG. 38.

He found that the secondary striking voltage, for a given distance increases with the primary current. That which increases in reality is the primary striking voltage, the only one measured.

It can easily be shown (B. No. 84) that, for a constant

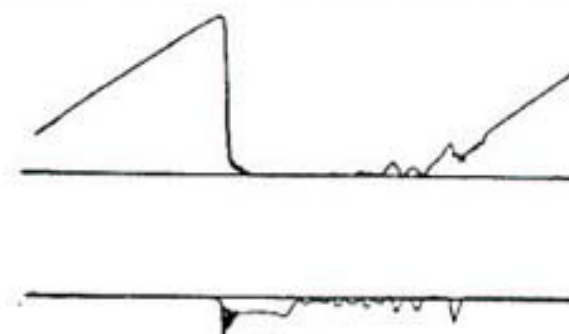

FIG. 39.

value of primary current, observed with the oscillograph, the maximum e.m.f. in the primary, also observed with an oscillograph, increases with the length of the secondary spark; this is shown by Figs. 38 to 41, which correspond to striking distances of 5 cm., 10 cm., 20 cm. and 30 cm., respectively. It is seen that the maximum ordinate of

the upper curve remains constant, while the lower curve, which represents the e.m.f. across the primary terminals,

$$RI + L \frac{dI}{dt} + M \frac{di}{dt}$$

increases with the length of the spark. The e.m.fs. measured on the oscillogram, are 277 volts, 330 volts, 425 volts

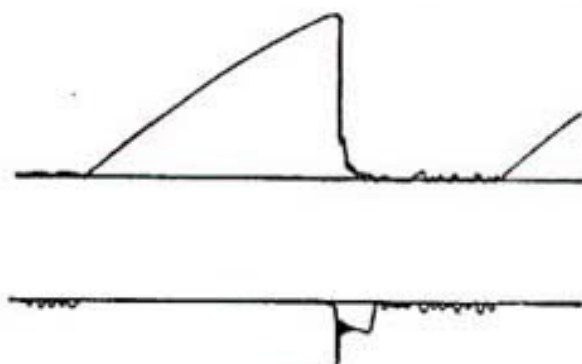

FIG. 40.

and 670 volts; the ratio of transformation being 155, and the secondary capacity being negligible, the corresponding secondary striking voltages between point and plate

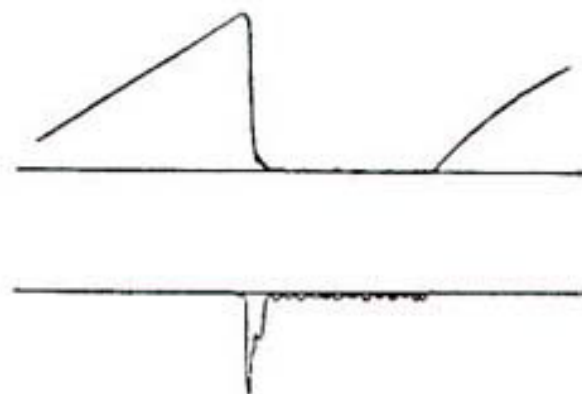

FIG. 41.

would be 43,000 volts, 51,000 volts, 61,000 volts and 103,000 volts—which are well within permissible limits.

Another experiment can be made, which will show the same results, but made in an inverse manner: Leaving

the length of the secondary spark-gap constant, and varying the maximum value of the primary current with the aid of a rheostat connected in the primary circuit, it is seen that the primary e.m.f., measured at the terminals, remains constant, regardless of the value of the primary current, providing a spark is produced in the secondary. This phenomenon is due only to the fact that the two sparks are not formed simultaneously. It must be shown from this that the maximum e.m.fs. in the two circuits are limited by the two sparks; this is why it is sometimes observed that when no secondary spark is produced, the insulation in the primary or in the condenser is ruptured; it is also this which causes the diminution in sparking at the interrupter when the length of the secondary spark is decreased.

Figs. 38 to 41 show also another phenomenon: The duration of the secondary current is inversely proportional to the length of the sparks, the maximum primary current value being constant. This duration explains the relative slowness of the demagnetization of the iron core and explains certain irregularities in high-speed mechanical interrupters. When the secondary circuit is short-circuited upon itself, the retardation of the demagnetization can be pushed so far as to force an interrupter, making normally about 50 breaks per second, not to make more than two or three breaks per second.

The different phenomena, which have just been described, (sparks, effect of iron, secondary capacity) complicate in a singular manner, the theory of the induction coil and make it, up to the present time, almost impossible to expect from mathematical treatment more than general indication of the rôle played by each factor when considered separately.

CHAPTER IV.

THEORY—ELECTROLYTIC INTERRUPTERS.

15. **Experimental results.**—The theory of electrolytic interrupters is still less known than that of mechanical interrupters. Before stating what is known, it is necessary to give a résumé of that which has been observed concerning the rôle played by the various factors of the phenomenon.

When two electrodes, having very unequal areas, are immersed in acidulated water and connected to a source of electric energy, it is seen that, up to a certain value of e.m.f. (35 to 40 volts), the electrolyte is simply decomposed; above this value of e.m.f. the phenomenon changes. The electrode, having the smaller area, becomes incandescent and can even melt if it is connected to the negative pole (cathode); it heats less and becomes a pink color if connected to the positive pole (anode). This phase of the phenomenon is accompanied by a peculiar noise, which Koch and Wüllner, in 1892, showed to be due to interruption of the current. Wehnelt (B. No. 44) first applied this idea to interrupters for induction coils; he employed as anode a platinum wire and as cathode a sheet of lead (Fig. 42). Some time afterwards Simon, in Germany (B. No. 59) and Caldwell, in England (B. No. 61) made the interrupter symmetrical by suppressing the anode with the small superficial area. The interrupter in this form becomes reduced to two electrodes having large superficial areas and immersed in communicating compartments connected together by a small hole, *T*, shown in Fig. 43.

Experiments made with the Wehnelt interrupter showed that the frequency of the interruptions, of which an idea

could be obtained from the sound emitted by the interrupter itself, or by the noise of the sparks, increases with the voltage of the source. The frequency depends also upon the direction of the current; it is greater when the small electrode is anode than when it is cathode. Other things being equal, the frequency is inversely proportional to the resistance of the circuit, to its coefficient of self-induction and to the active surface of the electrode. The presence of a secondary current also modifies the frequency, which increases when the secondary is closed or when very hot sparks are produced. When the temperature of the solution (electrolyte) rises the frequency diminishes.

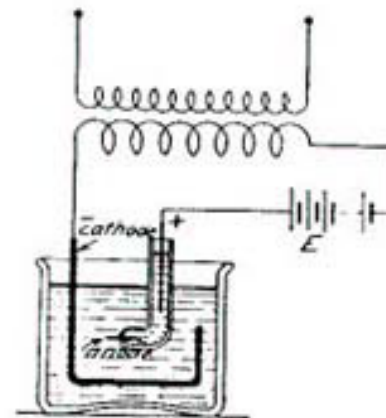

FIG. 42.

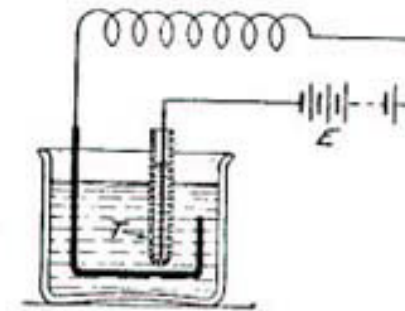

FIG. 43.

When the wave-form of the primary current through an electrolytic interrupter is observed, it is seen that it does not resemble that obtained with mechanical interrupters used with condensers; the break is made without oscillations (B. No. 56). Oscillations appear as soon as a condenser is connected in parallel with the electrolytic interrupter. This observation shows that the capacity due to polarization plays no important rôle in the phenomena.

Fig. 44 indicates, from rheograph observations, the variation of the wave-form of the current when different factors are varied. Increasing the surface of the anode raises the current value at which interruption takes place,

and, at the same time the interruptions are less frequent (see *a* and *b* in Fig. 44). The surface of the anode remaining the same, a resistance introduced into the circuit diminishes the frequency, but does not affect the maximum current value, I_{max} , providing the total resistance be less than $\frac{E}{I_{max}}$ (see *b* and *c* in Fig. 44). An increase in the coefficient of self-induction produces about the same effect as an increase in resistance; it decreases the frequency and changes slightly the form of the wave (see *g* and *h* in Fig. 44). In fact the time lost between break and make is so short that the secondary current, when sparks are produced, assists the establishment of the primary current. Without secondary discharges, it is seen that the current curve has an almost constant rate of increase (*d*); with white sparks,



FIG. 44.—*a*, small anode; *b*, larger anode; *c*, with resistance in the circuit; *d*, no sparks; *e*, white sparks; *f*, hot sparks; *g*, coil alone; *h*, with inductive reactance.

i.e., with slight discharge, the primary current increases rapidly at first and relatively very slowly afterwards (*e*); finally, if the sparks are very hot, or if the secondary is short-circuited, the rate of increase is so rapid that the rupturing value is soon reached and the frequency of the interruptions increased (*f*). The effect of the secondary current is so marked that a periodic variation of sound when the spark is hot enough to extinguish itself by the current of air which it produces, can be observed; the note emitted is noticeably lowered each time that a hot spark is thus broken and gives place to a white spark; this phenomenon has been photographed with an oscillograph and is shown in Fig. 45 (B. No. 84).

A very interesting fact is noted from examination of this oscillogram; namely, the current is not always inter-

rupted; in fact, the greater the frequency the less the current value approaches zero. The very peaked crests in this case (Fig. 45) are due to the small resistance of the primary circuit. Fig. 46 shows the effect of adding resistance; the wave-form in this case is more like the ones shown in Fig. 44; the frequency is about 330 interruptions per second.

The mean value of current depends directly upon the

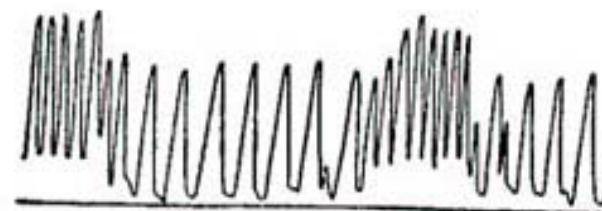

FIG. 45.

surface of the active electrode; it is nearly independent of the voltage of the source, of the resistance and the coefficient of self-induction of the circuit. It can be assumed as given by Wehnelt (B. No. 44), that the current density is about 0.4 ampere per square millimeter of anode surface.

Two factors affect the mean value of the current, namely, the temperature of the solution and the value of the secondary current. When the temperature rises the mean

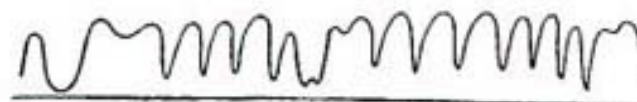

FIG. 46.

current value decreases; at about 90° cent., an anode having four or five times the surface must be used in order to obtain the same mean current value as that obtained at ordinary temperatures. The effect of the secondary current is twofold; it affects the wave-form and the maximum value (Fig. 45).

16. Phases of the phenomenon.—The phenomena which are produced in the Wehnelt interrupter are complex.

However, it is possible to distinguish three phases, according to the respective values of the different factors. At low voltage and at room temperature, the active electrode being the anode, a simple electrolysis of the solution is produced.

Increasing the e.m.f., E , interruptions commence, the formation of bubbles at the anode is more violent and the current value increases. The more the e.m.f. is increased the more marked these phenomena and the greater the frequency.

Above a certain value, the phenomena change. The platinum becomes red and the current value decreases;

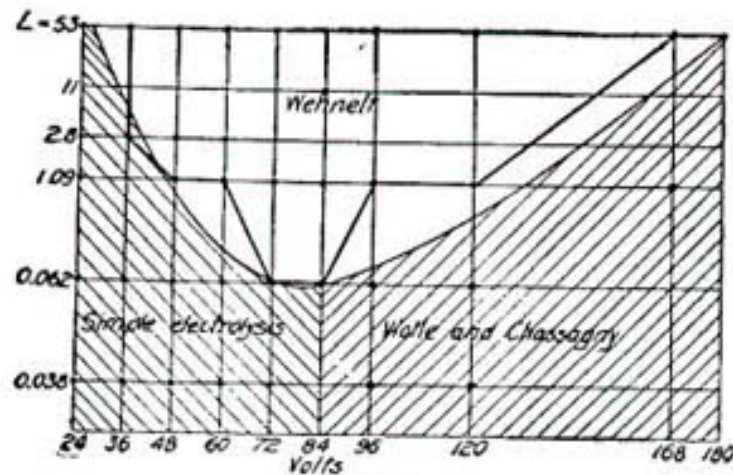

FIG. 47.

the interruptions cease. When this limit is attained, it is possible to reestablish the second phase by increasing the coefficient of self-induction of the circuit (B. No. 64).

Bary has studied the limits of these "phases" by varying the self-induction and the voltage; the results which he obtained (B. No. 51) are summarized in Fig. 47. The logarithms of the coefficients of self-induction are plotted as ordinates and the voltages as abscissas; the three phases are represented by different points, and the heavy broken line indicates the boundary between the Wehnelt phenomenon (2d phase) and the two others. This broken line is approximated by a smooth curve.

which represents the probable form of the boundary curve. The three "phases" are clearly separated in the figure, and it is easy to understand the experiment of Corbino (B. No. 64), who produces the second phase by introducing a bundle of iron wire into the core of a coil carrying the primary current.

The temperature of the electrolyte plays an important rôle in these phenomena; when it rises the boundary line lowers. At ordinary room temperature the second phase is obtained—the only one that is useful for induction coils, between 30 or 40 and 150 volts, according to the value of the coefficient of self-induction. When the temperature of the electrolyte attains 90° cent., the interruptions begin at about 10 or 12 volts, but it is impossible to run steadily at 100 volts. At temperatures above 102° cent., the dilute sulphuric acid boils, the interruptions become very irregular, and it is almost impossible to maintain operation with e.m.fs. above 30 or 40 volts.

The effect of pressure is equally marked. When the pressure is very low, the interruptions become slower and they may cease altogether (B. No. 52): under 60 mm. of mercury, the "lost time" increased; on the other hand, above atmospheric pressure (2 kg. per sq. cm., for instance), there is no lost time. For very high pressures, the phenomenon ceases, in the same way as for very low pressures.

When the direction of the current is reversed, *i.e.*, when the active electrode becomes cathode, the interruptions become less frequent and less sudden, the length of the secondary sparks much less and it becomes reduced to such an extent that the Wehnelt interrupter can be used to suppress one-half of an alternating-current wave, thus giving a discharge always in the same direction.

The active electrode, when observed with a spectroscope, gives a different spectrum depending on whether it is anode or cathode. In the first case (anode) the pinkish light which it emits is decomposed into brilliant rays, among which that of hydrogen is prominent. In the second case (cathode) the light is brighter and whiter and

there is the incandescence of platinum, the spectrum is continuous; the temperature is really higher, since the platinum often melts.

17. **Elements of the theory.**—The preceding experimental facts permit the formation of an approximate idea of the phenomena. There exists, between the active electrode and the electrolyte, a relatively high resistance; the current produces, at this point an amount of heat sufficient to vaporize the layer of solution; the steam forms an insulating envelope around the electrode and interrupts the current. At this moment, the rapid change in the current value produces an e.m.f. of self-induction, that is high enough to rupture the layer of vapor; it is this spark that gives the pinkish color to the light emitted by the anode; when the self-induction is too small, the pink color disappears. The envelope of vapor being destroyed, by a process as yet little understood, the solution regains contact with the electrode and the current is reestablished.

The nature of the resistance between the anode and the electrolyte is not known. Gaglière (B. No. 89) attributes it to the gas bubbles released by the electrolysis of the solution. If it is assumed that this release of bubbles is uniform, the electrode is surrounded by a layer of small and equal bubbles; and if it is further assumed that a surface concentric with the electrode cuts these bubbles in their long diameter, on this surface the conducting section is evidently very much reduced, the electrolyte becomes more heated than in other places and produces vaporization. According to this hypothesis the rupture would take place between two layers of electrolyte and not between the liquid and the anode; the platinum would not participate in the luminous phenomenon and its temperature would not rise above that of the boiling liquid. This hypothesis does not explain the dissymmetry of the Wehnelt interrupter, and it indicates that the current density at which the rupture is produced should vary with the diameter of the platinum wire, since the phenomenon takes place in a layer concentric with it,

and, consequently of larger diameter. It will be necessary to verify this deduction since it is contrary to all that we know up to the present writing.

The resistance, R_x , between the electrode and the electrolyte, is variable; it is a function of the area of surface, A , of the electrode, of the current value, I , of the temperature, t , and the time, T ,

$$R_x = \phi \left(\frac{I t T}{A} \right). \quad (1)$$

The value of the primary current, at any instant, is

$$I = \frac{E - L \frac{dI}{dt} - M \frac{di}{dt}}{R + R_x} \quad (2)$$

R being the resistance of the constant part of the circuit.

In order to form the vapor, a certain quantity of heat corresponding to the energy, W , must be liberated;

$$W = \int_0^{T_1} R_x I^2 dt. \quad (3)$$

The time T_1 at the end of which the rupture occurs, depends therefore, upon the resistance, R_x . It is difficult to say exactly how R_x varies before the rupture; neglecting the reaction of the secondary,

$$R_x = \frac{E - L \frac{dI}{dt}}{I} - R.$$

Examination of current curves shows that R_x increases and diminishes as a function of time; it is, therefore,

difficult to calculate I and $\frac{dI}{dt}$.

The difficulty is again increased by T_1 ; in fact, the

variation is so rapid that it is impossible to draw any certain conclusions from the oscillograph curves concerning the variation of R_x .

In absence of more accurate information, it is possible to draw some interesting conclusions from the equations. Neglecting the reaction of the secondary current, it is seen that the e.m.f. generated in the circuit,

$$e = -M \frac{dI}{dt} = \frac{M}{L} [E - (R_x + R)I]. \quad (5)$$

is proportional to the ratio of transformation of the coil; therefore, within certain well defined limits, it is advantageous to decrease the number of primary turns; this is verified by experiment. On the other hand, the diminution of L by changing the iron core, is useless, since M diminishes at the same time and the ratio remains constant.

It has been noted that the lost time in an electrolytic interrupter is very short. Simon (B. No. 58) considers it as constant; he also assumes the resistance, R_x , to be constant and then calculates the time required to produce the heat necessary for the formation of the envelope of steam. This calculation leads him to give as the complete period of the interrupter,

$$T = A + \frac{B}{E^2}. \quad (6)$$

This formula, which has been verified by Ruhmer (B. No. 63), has been questioned by others; it does not seem to be susceptible of general application, since the oscillograph shows that the resistance, R_x , is variable and rarely the same in two successive interruptions. It must also be remembered that E must remain within rather narrow limits in order to maintain the "second phase" of the phenomenon.

From equation (2) we have

$$\frac{dI}{dt} = \frac{E - (R_x + R)I}{L} - \frac{M}{L} \frac{di}{dt}$$

which shows the influence of the secondary current, i , upon the establishment of the primary current; if i is at

this instant decreasing in value, the factor, $\frac{M}{L} \frac{di}{dt}$, has the

same sign as E , consequently $\frac{dI}{dt}$ is greater than if E worked alone.

There is a very important difference between the performance of electrolytic interrupters and mechanical interrupters. With electrolytic interrupters, at the moment the primary current becomes zero, the total energy also becomes zero, since there is no primary capacity in which to store it. It is, therefore, impossible to have sparks at this moment, unless the capacity of the secondary be sufficient to accumulate a part of the energy.

The efficiency of the Wehnelt interrupter is very low, because of the considerable heating of the electrolyte; it is not unusual to find more than 80 per cent. of the energy dissipated in the form of heat in the interrupter alone.

All that we have said is equally applicable to the Simon interrupter, as well as Wehnelt's; R_x then represents the resistance of the liquid conductor which connects the two compartments. It is possible that this resistance may be more constant than in the Wehnelt interrupter; therefore, Simon's formula (6) is perhaps more applicable.

In the normal operation of the Wehnelt interrupter, the envelope of steam being formed, what is the cause of its disappearance? Some (B. No. 66) believe that the spark of the "extra" current ignites the explosive mixture at the anode and that the explosion drives away the steam. To this hypothesis the following objection may be made: The gas released from the electrolyte is always collected at the anode and the cathode, moreover if the gas at the anode is a mixture of hydrogen and oxygen it is indeed extraordinary that this mixture has escaped being ignited before. The solution adjacent to the envelope of steam seems to play the rôle of cathode, the steam and the

liquid appear to behave like two voltmeters connected in series. The volume of gas collected at the anode, according to Walter, is two and one-half times greater than would be expected according to Faraday's law.

Certain authors suggest the condensation of the vapor; others claim that the gas and vapor are released in quantities sufficiently large to account for the tumultuous movements of the electrolyte which reestablish the contact. Direct observation reveals an upward current of large bubbles, which burst at the surface of the electrolyte. Wehnelt observed, with a rotating mirror, the relatively slow formation of the gaseous envelope, then its dissolution into little bubbles, interrupting the current. Child (B. No. 62) calls attention to the fact that the high e.m.f., which exists between the points of rupture, produces a considerable electrostatic pressure upon the gas envelope, thus facilitating the expulsion of the vapor. Finally, Gagnière (B. No. 89) attributes the return to the original state, to the variation of the internal pressure of the bubbles and the surface tension of the liquid.

A very peculiar phenomenon takes place in the Simon interrupter. When one of the electrodes is placed in a perforated tube that is immersed in a jar containing the second electrode, it is seen that the operation of the apparatus causes the level of the liquid in the tube to rise or fall. The phenomenon appears to be caused by the relative facility with which the bubbles of gas and vapor are formed at one side or the other; in certain cases, this is of great importance since it is possible to obtain a change in level of about one meter.

18. **Electrolytic interrupters for alternating current.**—With alternating current the Wehnelt interrupter gives unequal interruptions, which is just what would be expected from what is known of its characteristics. Messrs. Kallir and Eichberg (B. No. 54), who studied the operation of the Wehnelt interrupter with alternating current, observed that the discharge did not commence until the instant when the positive half of the wave had attained

a certain value and from this instant the interruptions became more frequent as the maximum of E was approached, and then decreasing in frequency toward the zero value. The same phenomenon was observed in the negative half, except that the secondary sparks were extremely short.

This phenomenon can easily be observed with an oscillograph (B. No. 84), if care is taken to keep the value of the coefficient of self-induction so low that numerous interruptions will take place in each wave half. Fig. 48 shows distinctly the difference between the positive and the

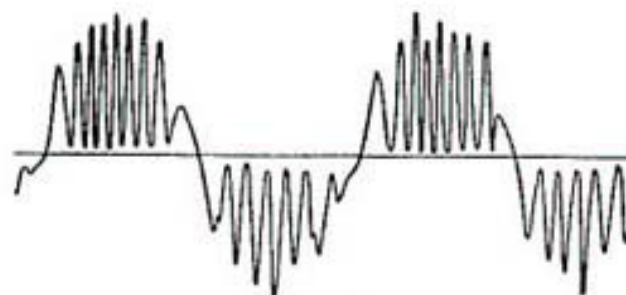

FIG. 48.

negative half of the wave; the frequency being less in the negative half. It is also seen that the frequency is greatest for the maximum amplitudes.

The difference between the positive and negative disappears when a Simon interrupter is used; this type being perfectly symmetrical. The sparks are equal in length for each half-wave but are opposite in sign.

When a Wehnelt interrupter is used for rectifying alternating current, it often happens that the active electrode becomes fused, because as is well known the platinum point, when used as cathode, heats considerably.

CHAPTER V.

THE SECONDARY CURRENT.

19. **Striking or disruptive voltages.**—In order that a spark shall pass between two conductors that are separated from each other, there must exist between them a difference of electrical potential, the value of which depends upon the length of the gap, the form and nature of the conductors, and the nature and condition of the medium in which the spark must form. The difference of potential, which is often called the striking voltage, has been determined by various physicists, under varying conditions, and the results obtained, which differ greatly from one another, should be considered only as approximate indications of magnitude of the e.m.fs.

All bodies oppose the establishment of a spark with a certain resistance that varies in value with the thickness. The striking voltage necessary to rupture one centimeter of the substance considered, is often called the dielectric strength. The ratio of the striking voltage to the thickness is not constant; the dielectric strength decreases (air) with the thickness.

Figs. 49 and 50 show striking voltages found by various experimenters, for air under normal conditions of pressure and temperature.

The values given by Joubert were obtained from experiments made with a static machine charging condensers; the sparks were formed between brass balls 22 mm. in diameter.

Thomas Gray (B. No. 37), who has extensively investigated the dielectric strength of many different insulating materials, measured the strength of air by passing sparks between two plates.

C. E. Skinner (B. No. 38) measured the striking voltage between two needle points; the e.m.f. being furnished by transformers capable of giving 200,000 volts. The figures given by this author indicate the mean effective value of the e.m.f., the wave-form being taken as sinusoidal. In comparing this curve with the others given in Figs. 49 and 50 the values given by Skinner must be multiplied by $\sqrt{2}$.

The German physicist Oberbeck (B. No. 40) made some

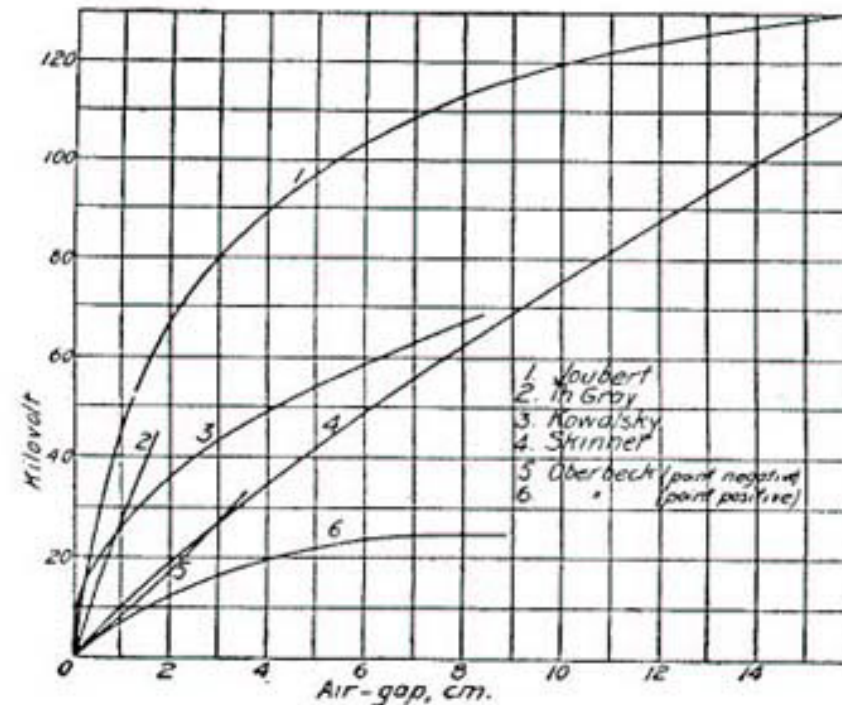

FIG. 49.

measurements of the striking voltages between a plate and needle point and established the well known fact that the striking voltage is greater when the point is negative than when it is positive.

Klingelfuss (B. No. 74) measured the striking voltage directly, using an induction coil; he used as electrodes a plate and a point, the latter being positive. It was explained on page 59 why these results can be considered as the upper limit.

Finally, of the numerous determinations which have been made, those made recently by de Kowalski (B. No. 87), are given. He measured the e.m.f. between a brass ball 2 cm. in diameter and a plate of the same metal 158 mm. in diameter. The tests being made with e.m.f. supplied by a continuous-current generator that was used to charge condensers; under these conditions the e.m.f. can be very accurately measured with ordinary commercial voltmeters.

The curves in Figs. 49 and 50, excepting that of Klingel-fuss, show clearly that the voltage increases less rapidly

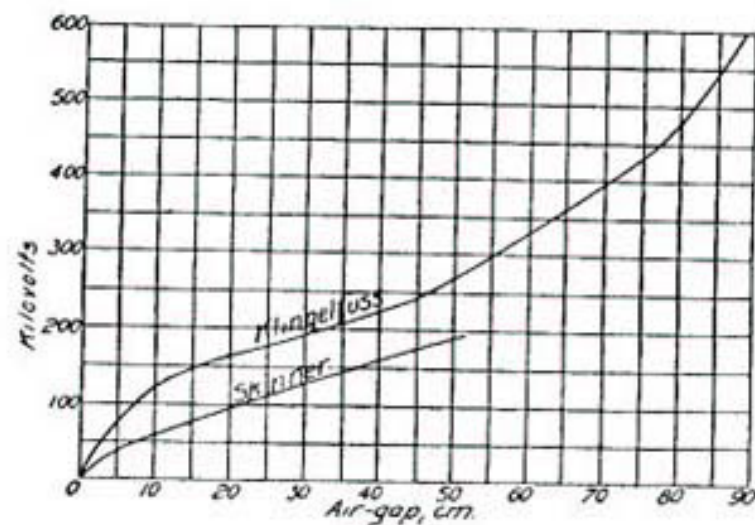

FIG. 50.

than the distance. This fact should be borne in mind, because it would be possible to conclude that since the curve of the maximum current values as a function of the spark lengths (Fig. 17) shows a point of inflexion, the coil or the interrupter has some irregularity in its operation.

Dr. C. Baur (B. No. 86) gives an equation for the mean striking voltage of dielectrics.

$$E = c l^{\frac{2}{3}},$$

wherein l is the thickness of the dielectric (spark-gap), which corresponds to the voltage, E , and c a constant. This formula fits the general form of the curves very well.

In reality, the nature of a spark is not so well defined that absolute values can be attached to quantities shown by the curves described above.

The pressure of the gas has a marked effect on the sparking distance. The striking voltage decreases with the pressure down to a certain value—a few millimeters for air—then it increases very rapidly and becomes very great for the most perfect vacuum that can be obtained in practice. Above the atmospheric pressure the striking voltage increases.* In both cases, above and below normal pressure, the nature of the spark changes.

20. Sparks.—In order to obtain the longest possible sparks with a given value of e.m.f., the negative electrode must be a plate and the positive one a point; in which case the sparks are directed at the center of the plate, or just

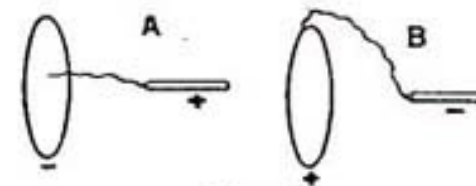

FIG. 51.

about as shown in A (Fig. 51). The spark may be white and noisy, or more or less yellow, thick and silent; at the surface of the plate the spark is whiter and more luminous, due to the metallic vapors. When, on the other hand, the point is made negative and the plate positive, the value of the e.m.f. must be much greater and the sparks, instead of forming between the center of the plate and the point, start from the edge of the plate, B (Fig. 51). This difference is very characteristic, it forms one of the best means of determining the polarity of the discharge from an induction coil.

When the distance between the point and the plate is much less than could be used with the coil the spark is

*Professor Ryan found that for pressures up to about 150 lb. per sq. in., the dielectric strength of air varies directly as the absolute pressure and inversely as the absolute temperature.—O.A.K.

thick and silent and the difference in polarity of the discharges disappears almost completely; for this reason, the point and plate should be separated as much as possible when it is desired to distinguish the polarity of the discharge.

When the sparks are furnished by a sufficiently powerful source, they are clear and give a characteristic crackling sound, providing the voltage greatly exceeds the striking voltage; in this case the sparks approach an arc. If the source is not sufficiently powerful the electrodes become slowly charged to the same potential as before, then form a continuous and silent brush discharge, which is scarcely visible, making it appear that the striking voltage has not been quite attained. If, without changing anything else, the e.m.f. of the source is increased, the brush discharge increases in magnitude and sparks are formed without there being any sudden change from one phenomenon to the other. It is, in a great measure, due to this difficulty in distinguishing the dividing line between brush discharge and actual breakdown, that such different results for the striking voltage are obtained. When a condenser charged to a high voltage by a generator is used as a source, the first spark jumps just as soon as the striking voltage is reached; this spark heats the air and reduces its resistance; then a second spark is formed and so on the frequency steadily increasing up to a certain limit, which is determined by the renewal of the air; the heated air rises and is replaced by cold air which again increases the resistance. If the voltage is kept constant, and the available power is increased (for instance, by decreasing the resistance of the primary circuit), the frequency of the sparks increases up to the moment when the circuit is closed short through the envelope of hot air; at this point a sort of arc, having a low but finite resistance, is formed (B. Nos. 60 and 87). Everything that tends to disperse this envelope of hot air, such as a draught of air or a magnetic field, will tend to reestablish sparks and extinguish the arc.

In the succession of sparks which have just been described

the first are white, thin and straight or composed of straight lines; their sound is sharp. When the heated air facilitates the passage of sparks, their color changes, they become yellow or reddish; their sound becomes softer. Finally, when the arc forms its size depends upon the value of the current; it is completely silent when the current is continuous and produces a sound depending on the frequency when the current is alternating.

Summing up, all that need be remembered, since we are going to apply it to induction coils, is that discharges between two conductors always begin with one or several separate sparks, after which the performance depends upon the power of the source.

In order to have it complete, it should be added that brush discharge precedes the first spark. This phenomenon has been photographed by Walter (B. No. 57).

Since the discharge cannot take place except for a certain e.m.f., it is possible, providing the secondary capacity is small, to neglect the action of the secondary circuit up to the moment when the sparks or brush discharges appear; thus justifying the assumptions made in developing the elementary theory in Chapter III.

21. **An outline of disruptive discharge.**—Assume a coil of average dimensions, using a low-frequency interrupter, so as to separate the successive discharges, and excite the circuit with a current of proper value. If the spark-gap terminals are too far apart, no spark will be produced; but in the dark brush discharge and corona effect can be seen along the external secondary circuit, especially where there are points or projections; the effect is sometimes beautiful. Bringing the electrodes nearer together sparks are produced, at first white, thin, noisy and seldom straight, more often in the form of a broken line. Bringing the electrodes still nearer together the sparks become fatter and more noisy. Continuing to reduce the spark-gap the sparks become fatter and less noisy; they turn yellow or red, retaining a sort of a white core that is more luminous than the rest of the spark. Finally, for a very

short air-gap each discharge is a thick spark, making a low hissing noise and appearing like a light yellow flame the center of which is a little deeper color; the spark is very hot; it instantly ignites paper and is constantly being carried up by the current of heated air

In certain induction coils the sparks are never yellow; they always remain white and brilliant, and the crashing noise increases when the gap is decreased; these are veritable condenser sparks due to the relatively large capacity of the secondary.

The same succession of phenomena could be obtained by fixing the electrodes to give a short enough air-gap and gradually increasing the current, leaving the spark-gap constant.

The curves shown in Fig. 52 will aid in explaining what

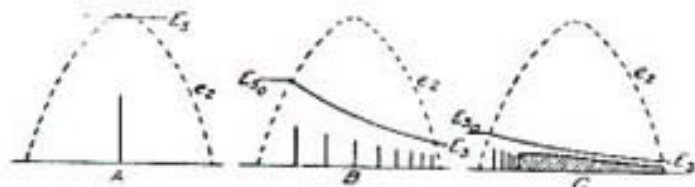

FIG. 52.

takes place. The first semi-oscillation of the secondary e.m.f., e_2 , at first just attains the striking voltage, E_s , one spark is produced (A, Fig. 52) (the duration of the sparks being unknown they are represented here by simple vertical lines). Decreasing the length of the gap (B, Fig. 52), a spark is produced as soon as e_2 reaches E_{s0} and the conductors are discharged; but the coil continues to furnish energy, the e.m.f., increases again and a new spark is formed and is followed by others until the e.m.f. is no longer great enough to raise the electrodes to the striking voltage.

How does the phenomenon of disruptive discharge take place? The first spark heats the air so that the second encounters less resistance, and so on; the result is that the striking voltage is continuously decreased from E_{s0} to E_s (B, Fig. 52), and that the frequency of the sparks continuously increases from the beginning to the end of the

discharge. Abraham (B. No. 60) observed analogous phenomena in the discharge of condensers, that were charged from an alternating-current source. It is evident that in the descending portion of the curve, e_2 (B, Fig. 52), the frequency of the sparks could decrease because of the decrease in the e.m.f. It is this part of the discharge that appears to the eye to be a single fat spark.

When the air-gap is still more reduced the striking voltage, E_{s0} , decreases (C, Fig. 52), and the frequency of the sparks increases; the heating of the air is greater than before, so that the e.m.f. is sufficient to strike and maintain an arc; the arc is represented by the cross-hatched portion of the curve in C, Fig. 52. In this case the partial sparks at the beginning produce the white core of the hot sparks.

The conventional representation of the sparks given in Fig. 52 does not exactly represent what takes place. Each spark, represented by a single vertical line, may be a very complicated phenomenon; it may contain a great many oscillations, or it may consist of a great many discharges in the same direction. However the duration of the total discharge (one spark) is so short in comparison to the wave of secondary e.m.f., e_2 , that it is impossible to represent both phenomena to the same scale.

22. **Properties of sparks.**—Although, as was said before, the sparks do not differ from one another in a well defined manner, the characteristic features have been established for each phase. The white spark, when observed with a spectroscope, always gives the lines of the metals between which it is formed. When the spark is long, the white part of the spark is often found only near the negative electrode, and it is here only that the lines of metal are found in the spectrum; in the rest of the spark, as in all hot sparks of yellow or red color, the spectrum is striped, like that of gas.

The experiments of Hemsalech showed that in the discharge of a condenser, charged by an induction coil, there are nearly always obtained for each discharge several

oscillating or intermittent sparks, and the reason that the first straight-line spark is very brilliant, is that the air is incandescent; the metallic vapors come afterward and mix with the heated air. It seems that, without a condenser and for long sparks, the phenomena are not the same; the arc, when it is produced, does not show any metallic lines, at least, they are hidden by the spectrum of air.

The white sparks, which, as we have seen, cause sudden and more or less frequent variations in the current value, naturally have very marked inductive properties; this can be demonstrated by a very simple experiment (B. No. 39). Connect in the secondary leads to the spark-gap, a loop of wire several centimeters in diameter, the terminals of

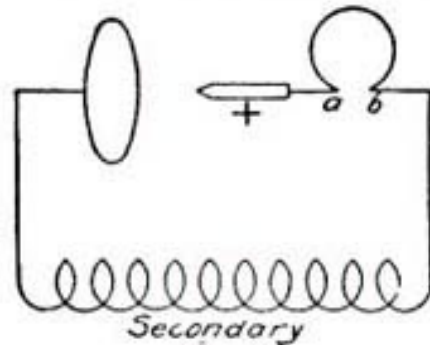

FIG. 53.

which can be connected by a micrometer gap, a, b , in Fig. 53. Between a and b the difference in potential will be proportional to

$$Ri + L \frac{di}{dt}$$

R being the resistance of the loop, L the coefficient of self-induction, and i the value of the current which is established across the spark-gap; the wire can be made so large that R may be neglected. As long as the variations in the value of i are small, there are no sparks between a and b ; this is the case when the spark is hot.

As soon as the white sparks appear, a small spark passes across a, b , the gap offering less impedance than the loop;

these sparks are due to very great variations, $\frac{di}{dt}$, and also to the fact that the instantaneous value of i is infinitely greater than would be judged from the mean value of the current. Anything that tends to establish white sparks in the main gap will produce sparks at a, b ; for instance, if a hot spark is established between the terminals, by blowing against it one can show that simultaneously with the formation of a white spark there is a discharge at a, b .

The hot spark corresponds to a lesser e.m.f. drop, because the resistance of the heated air is less than that of cold air. However, the air-gap does not behave like a metallic conductor; no spark can pass until a definite potential difference has been reached. This fact can be demonstrated by a simple and interesting experiment: A coil is excited by a powerful source, and is provided with a very rapid interrupter—a Wehnelt, for instance. The spark-gap is adjusted to give a very hot spark, a sort of an arc some centimeters in length. If, now, a wire is attached to one of the electrodes, preferably the positive and if the other end of this wire is brought near to the negative plate, it is seen that the distance between the plate and the wire must be made four or five times less than the spark-gap before a spark will form there in preference to its old path; then it will completely abandon the first path in favor of the second. Afterward the wire can be drawn away from the plate, and the spark lengthened; it will not resume its old path until the distance becomes so great that the discharge is stopped; it is also possible to lead the spark back to the point electrode. This experiment shows that even with a very hot spark, the resistance is great because it absorbs an e.m.f. sufficient to break down several centimeters of cold air, and also because no discharge will take place in the heated air below a certain value of potential difference, since the shunted gap immediately takes all the discharge.

Up to this point we have considered only sparks which are distinctly separated from one another, such as would be obtained with low-frequency interrupters: the last

experiment shows that the aspect of things changes when the interval between two consecutive sparks is so short that the path of heated air has not time to escape.

With rapid interrupters, the striking distance being that which corresponds to white sparks, the discharge is at first a flux of crackling sparks, which is more or less quickly transformed into a hot and silent stream, often streaked with white lines; this phenomenon is often obtained with the Wehnelt interrupter.

The high-speed interrupters sometimes facilitate the discharge in the following manner: The coil being unable to break down the air-gap, corona and brush discharge will take place with each interruption of the current, and these phenomena heat the air, so that, at a certain instant, a discharge between the electrodes will take place. (The violet rays from the brush discharge also act to render the gap more conducting.) The discharge, once established, will continue. It should be noted that, in this case, the discharge most often changes from brush discharge to a hot spark, because the greater heating effect of the hot spark tends to facilitate the discharge. It is generally in this manner that the hot sparks, given by electrolytic interrupters, are formed.

When the sparks are once established, it is possible to increase the spark-gap: with the very high frequency given by the electrolytic interrupters, it is easy enough in this way to double the length of the spark; it is for this reason that certain persons have claimed to have obtained much longer sparks with electrolytic interrupters than with mechanical interrupters.

The decrease in the resistance of the air, when the temperature is raised, can be demonstrated in the following manner: The electrodes being placed far enough apart to prevent a discharge, approach the gap with a flame, (gas jet, alcohol or even a match), when the discharge will immediately take place. This experiment will succeed if care is taken to adjust the spark-gap so that it just slightly exceeds the explosive or striking distance.

CHAPTER VI.

POWER AND EFFICIENCY OF INDUCTION COILS.

23. **Power and efficiency.**—The power absorbed by a coil depends upon the resistance of the primary circuit, on the coefficient of self-induction and the e.m.f. employed; often also, when the secondary is closed upon itself or through a large capacity, the power is a function of this circuit also. No matter what the conditions of the primary circuit may be we have seen that only a part of the energy absorbed is utilized for induction; this is the energy which has been stored in the magnetic field, namely:

$$W_1 = \frac{L I_{\max}^2}{2}.$$

In a coil excited by a continuous-current source of e.m.f. E , the energy absorbed at any instant is

$$E I dt,$$

and since E is constant, the power absorbed is

$$P_0 = \frac{E}{T} \int_0^T I dt = E I_m;$$

the product of the constant e.m.f., E , and the mean value of current, I_m .

If n discharges are produced per second, the power utilized for induction is $n W_1$, and we can define the primary efficiency as

$$\eta_1 = \frac{n W_1}{P_0} = \frac{n L I_{\max}^2}{2 E I_m}.$$

this is called the efficiency of the circuit; it will be seen that it is possible by proper choice of the factors, E and R , to increase the efficiency to a maximum value.

With each discharge, the energy W_1 , is released; part being dissipated as heat in the secondary and in the iron core, the rest being utilized. If the useful energy is designated as w , the ratio, η_2 , between w and W_1 , represents what is called the secondary efficiency of the coil,

$$\eta_2 = \frac{w}{W_1} = \frac{2w}{L I_{max}^2}$$

The product of η_1 and η_2 represents the total efficiency, η ,

$$\eta = \eta_1 \eta_2 = \frac{n w}{E I_m}$$

Little is known of the total efficiency of a coil, because it is almost always impossible to find the "secondary efficiency" of a coil.

The efficiency of the circuit is easy enough to determine, when the coefficient of self-induction, L , and the number of interruptions, n , is known, because the measurement of the power-input, $E I_m$, is a very simple matter.

The total efficiency can scarcely be determined except in two cases. When the secondary circuit is closed through a constant resistance, r' , and the mean effective value of the current is i_c , the useful power is

$$P = i_c^2 r',$$

and the total efficiency is

$$\eta = \frac{i_c^2 r'}{E I_m}$$

The second case is when the secondary circuit is closed through a relatively large capacity; if, then, the longest possible sparks are obtained, it can be assumed that the

energy stored in the secondary capacity is entirely utilized in the discharges, so that the energy of each discharge is very closely

$$w = \frac{c e_2^2}{2},$$

and the secondary efficiency may attain

$$\eta_2 = \frac{c e_2^2}{L I_{max}^2}$$

from which, if n is known, the total efficiency is

$$\eta = \frac{n c e_2^2}{2 E I_m}$$

In this test it is well to use balls for the spark-gap terminals, so as to be able to refer to known striking e.m.f.s., or better yet, to measure by another method the e.m.f. corresponding to the length of spark obtained. A good precaution is to use low-frequency sparks so as to avoid heating the air and the terminals of the gap.

In experiments made on various types of coils charging Leyden jars of large capacity, the author has never obtained an efficiency above 50 per cent., and generally nearer 40 per cent.

The efficiency of the circuit is easier to measure and it can, in many cases, be improved; the factors which can be manipulated to this end are: The e.m.f. of the source, the duration of the contact and the resistance of the circuit. If, for instance, the current value, I (Fig. 54), is required, we know that this value is attained after a certain time; the higher the e.m.f. the shorter the time. Since the copper loss in the circuit is

$$R \int_c^I I^2 dt,$$

it is seen that it is proper to reduce the time by increasing the e.m.f., E , as much as the interrupter will permit.

Increasing the resistance, R , of the circuit, by a rheostat, (a common practice), is contrary to proper utilization of the energy; but since it is a safeguard to the coil, it is better to sacrifice a little of the efficiency in all cases where there is a fear that the contact will be too long for the e.m.f. employed.

The efficiency increases with the e.m.f. of the source, but the rate of increase of the efficiency is not constant. It falls off, so that there is a value of e.m.f. above which

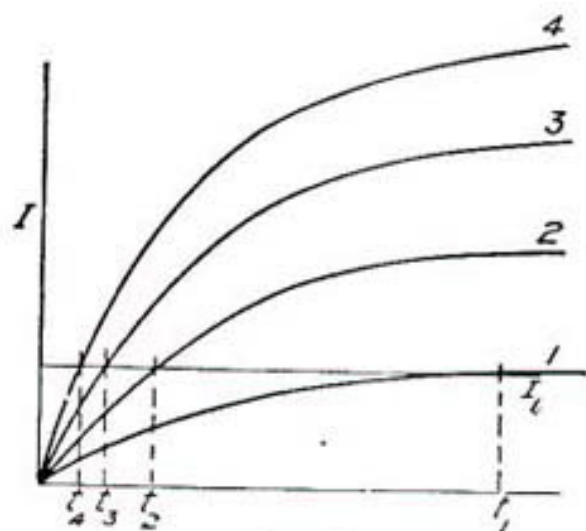

FIG. 51

it is useless to go; this value is generally equal to about $10 R I_{max}$.

However, the efficiency is not the only point which has bearing on the subject, it is often convenient to utilize lighting circuits at 110 or 220 volts; with sufficiently rapid liquid interrupters a good utilization of the energy is obtained, providing it is not necessary to employ rheostats in series for regulating the current value.

With mercury interrupters, in which the duration of contact can be regulated, the regulation should be such as to give a value which will permit the attainment of very

near the necessary current values, but the duration of contact should never be prolonged much beyond this point, because the energy will be expended in pure loss.

The increase of the voltage, E , permits a reduction of the duration of contact, it increases the efficiency and also permits the use of an interrupter of higher frequency; therefore, the usual power of the coil, that is, the energy which it can furnish in a given time under given conditions, is increased.

If the number of interruptions, n , is increased by simply reducing the "lost time" between two consecutive discharges, the power of the coil is increased. But without any change in efficiency, the ratio between the output energy and the input energy in each discharge remains the same.

With electrolytic interrupters, the total efficiency may be measured in both cases mentioned above. However it is very difficult to separate the efficiency of the coil from that of the circuit, since the resistance of the interrupter varies from instant to instant.

In order to compare two coils, it is necessary that the conditions be as nearly identical as possible and that the power absorbed by each for producing a given effect, be measured; however, it is possible to find for different coils certain circuit conditions and methods of use, such that the useful results will be equivalent; the comparison should not be made until the most favorable conditions for each coil have been investigated.

With continuous current the power absorbed by the coil should be measured with a wattmeter, or, more simply and accurately, with any voltmeter and a Weston ammeter. Since it is necessary to know the mean value of the current, all ammeters giving the mean effective value: Hot-wire, electro-dynamometer, electromagnetic—should not be used in this case, as their use may lead to very serious errors.

In the secondary circuit, instruments should be used which give the mean effective value, because the two factors, e_2 and i_2 , are variable.

When the coil is connected to an alternating-current circuit, a wattmeter must be used for measuring the power absorbed; there is no reason why the value of the current and mean effective voltage should be measured, except where it is desired to control the regulation.

24. **The measurement of constants.**—It is not within the scope of this work to enter into details of testing, and we will limit ourselves to pointing out the importance and choice of methods.

Resistance of the two circuits of a coil should always be known, and when there is fear of an accident in the coil, it is the first measurement to be made. A coil in which the secondary is broken may continue to give apparently good results, but a little spark between the broken points is capable of putting the whole coil out of service. By verifying the resistance from time to time, it is possible to detect such an accident before it has assumed much importance; this verification should always be made after the coil has been transported, or has undergone mechanical shocks which could cause the wires to rupture.

The measurement of resistance does not require very great accuracy, from two to three per cent. at the most, because it is difficult to know the temperature of the mass within about five degrees centigrade. This lack of precision makes it impossible to discover the short-circuiting of a few turns in the secondary—an accident which frequently occurs, and which is capable of putting the coil out of service.

In case a Wheatstone bridge is not available, the resistance of a coil can be measured with a milliammeter or voltmeter, the value of the current derived from a known e.m.f., such as that from a continuous-current lighting network, for example.

There are numerous methods for measuring capacity, but most of them require perfect condensers, which requirement is seldom fulfilled by coil condensers; in each there generally exists a very strong polarization and a relatively considerable conductivity; these two faults do not interfere with the operation of the coil, but they render

the measurement of the capacity more difficult. The method to be most recommended for this sort of work, is that of Sauty. By replacing the galvanometer by a telephone, and the continuous current by an alternating current, the capacity thus measured is, indeed, that which should be used in the calculation of the oscillations. It is always smaller than that obtained by the ballistic method, because the capacity due to polarization is almost completely eliminated.

The measurement of the coefficient of self-induction is often considered difficult; in reality it is just as easy to measure as resistance; it is simply a matter of choosing the method most adapted to the circuit. For induction coils, since all coils contain iron, zero methods should not be considered, and the deflection methods should be used. The method used by Rayleigh of comparing a coefficient of self-induction with a resistance is generally the most convenient.

It should not be forgotten that the coefficient of self-induction of a coil containing iron is a function of the ampere-turns. (Fig. 34); consequently, measurements which do not indicate the value of the current are useless; it is necessary to make several measurements corresponding to current values between zero and the maximum which will be used in the coil. In measuring the coefficient of self-induction of the secondary, it is necessary to choose current values which will give about the same number of ampere-turns as that obtained by the primary current values.

The coefficient of mutual induction should also be determined for the same primary current values. In a rigorous test it would be necessary to take the secondary current into account, but since this latter is rarely known, it is necessary to measure the induction, assuming the secondary current to be zero. The most simple method is that of deflections in which the quantity of electricity produced in the secondary by reversing the primary current of which the value is known, is measured. The ratio of

transformation, when it is not already known, may be determined by the ratio of the coefficients:

$$\frac{M}{L} \cdot \frac{l}{M} \sqrt{\frac{l}{L}}.$$

In order that the ratio of transformation thus measured be exact, it is necessary to introduce in the ratios the values which correspond approximately to the same number of ampere-turns; for M and L it suffices to know their value for the same primary current. For the other ratios,

$$i = I \frac{l}{m} = I \sqrt{\frac{l}{L}},$$

which may be done after a preliminary measurement with any value of current has given an approximate value to the ratio of transformation.

25. Coil testing.—That which has been said concerning operation of coils and interrupters shows the complexity of the phenomena and demonstrates that there should be almost as many methods of testing as there are special applications for coils. There are, nevertheless, certain general tests which can be made, because they are characteristic of the worth of the coils. Among these tests, one of the most important is the determination of the length of the secondary sparks as a function of the primary current values. As was seen in Chapter III in tracing a curve of maximum current values as a function of the corresponding spark length, (Fig. 17), a sort of characteristic of the coil is obtained for a given condenser and interrupter. The form of this curve and its constancy are the best guarantees of the given condition of the coil.

The method of determining this characteristic of the coil consists in testing it with an interrupter giving a constant duration of contact which is long enough to permit the establishment of the full value of current as represented by the equation, $I_{max} = \frac{E}{R}$.

It is necessary to use a high voltage, that of a lighting circuit, for example, and insert a resistance in the circuit,

so as to be able to vary the maximum value of current. The current is measured with an ammeter when the interrupter is stopped and the circuit closed.

For different values of current, I_{max} , determine the maximum lengths of sparks which it is possible to obtain and plot these lengths as abscissas, the corresponding values of current being plotted as ordinates.

Several curves may be constructed for different capacities. In this way the optimum capacity may be determined. However, this optimum capacity holds only for the particular interrupter employed in the test. When the coil has been in operation for a certain time and it is desired to determine its condition, these tests should be repeated under identical conditions.

The test should always be conducted progressively, commencing with the short sparks and plotting the results obtained in the form of a curve, as soon as the curve has passed the point of inflection (Fig. 17)—that is, as soon as it becomes convex to the abscissas. The primary current should be increased very carefully, because this may be an indication of small discharges which take place within the coil. When the curve turns up too rapidly, increasing the primary current will have little effect on the length of the spark, and this length should be considered the practical limit, which should not be exceeded.

Rapid interrupters and those in which the rupture is a function of the current value should not be used in this test; because one would be tempted to plot the length of the spark with a mean value of current, which is an indication much too vague to be of use.

The optimum capacity can generally be judged by the result obtained; its exact determination is quite difficult, because the effect produced is often impossible to measure directly. Sufficiently good results are generally obtained by choosing a capacity which gives, other things being equal, the greatest length of spark. In radiography the aspect of the tube, the uniformity and the intensity of the light emitted, are good guides in choosing the capacity to be employed. Unfortunately, it is not

possible to give more precise indications on this subject; the cleverness of the operator plays an important part, one which it is impossible to eliminate.

26. **Accidents and faults in coils.**—Faults in coils are numerous and often very difficult to locate. The following indications may in some cases serve to recognize these faults, but in repairing them it is best to call in an electrician who possesses not only the tools necessary, but considerable experience in this line of work.

Open circuits sometimes occur in the coil winding; they are easily recognized by measuring the resistance. When the primary circuit is opened, the fault is immediately discovered because the small e.m.f. of the source will not be able to establish any current in the circuit. It often happens that the wire is broken, but still in contact; in this case variation in the resistance of the contact will serve to indicate the trouble.

When the secondary coil is opened, the operation of the coil will not be immediately affected; but at the end of a certain time, the small spark which forms between the ends of the broken wire burns the insulation of the neighboring turns and short-circuits them, thus rapidly reducing the useful effect of the coil.

A much more frequent accident is the short-circuiting completely, or partially, of the primary. Often this short-circuit is dead and can be detected by measuring the resistance, but more often it results from the carbonization of the insulation by the sparks due to self-induction; in which case the carbon residue offers a considerable resistance to the test current, and in this way the primary resistance appears not to have varied; but when the coil is in operation, the current due to self-induction of the winding finds an easy path. Energy is dissipated at this point, and the coil furnishes much shorter and weaker sparks. When this accident occurs, generally a very marked diminution of the spark at the interrupter is noted, which is easily visible in dry interrupters, and which makes itself known in mercury interrupters by a characteristic heavy sound.

The short-circuiting of several turns is much more difficult to detect. However, this accident reduces to such an extent the efficiency of the coil, that it is almost impossible not to notice a deviation from normal operation. When one is certain that all other causes of perturbation are eliminated, the fault may be located by burning out the part which is short-circuited. The coil being placed on short-circuit, and a high voltage applied with a Wehnelt interrupter, furnishes a very hot spark of length corresponding to its normal operation; at the end of a very short time, the short-circuited turns, which are the seat of a very large current value, melt the insulation which surrounds them, and thus indicate the location of the fault. It is preferable to allow an expert to make this test.

A condenser may also be short-circuited; it is usual to detect this by measuring the resistance of the dielectric; an ordinary voltmeter is put in series with the condenser and connected to direct-current lighting mains. In case of a short-circuit, the indication of the voltmeter will be about the same, whether the terminals of the condenser are short-circuited or not.

Another case presents itself; namely, an abnormal resistance in the conductors which connect the condenser to the interrupter; the sparks due to the self-induction of the primary winding then become much stronger, and those in the secondary very much weaker. The nature of this trouble will only be recognized after a careful examination of the entire coil; a convenient method consists in removing the condenser from its box and connecting it directly and securely by short wires to the interrupter.

When the insulating tube, which separates the primary from the secondary, becomes punctured, or in general, when a spark passes between the two circuits, the secondary retains a residual charge, which can easily be detected by touching the terminals with a hand; this residual charge is very characteristic of leakage between the two circuits; it is often an indication that the length of sparks employed is too great for the coil.

CHAPTER VII.

CONSTRUCTION OF INDUCTION COILS.

27. **The primary.**--The primary is the part easiest to construct, however, it is necessary to take certain precautions in order that the coil give results that are not mediocre.

In the classical form, the iron core is straight; it is formed of iron wires varying from 1 to 2 millimeters in diameter, which are arranged and assembled in concentric layers about a more rigid core of iron from 6 to 8 millimeters in diameter. These iron wires should be arranged with great care, so as to obtain the best utilization of the space; they are laid on layer by layer, each layer being covered with a coat of varnish. In small coils less care is taken; the wires are simply assembled in a bundle, tied together and all varnished at the same time. Many times they are neither varnished nor tied together. When the necessary diameter has been obtained, the iron core is dried in an oven and is afterward covered with a layer of insulation, the thickness of which depends upon the size of the coil. This insulation is made of varnished paper, of linen, or any other solid insulator.

The primary wire is then wound upon the core in one or two layers. In case several layers are employed, it is good practice to insulate one from the other with the same kind of material that is used to insulate the core, because it should be remembered that there may exist between the terminals of the primary, e.m.fs. of several hundred volts.

The size of wire to employ depends upon the dimensions of the coil, the value of current which it has to carry and the duration of continuous service. The diameter of the primary wire varies from 0.6 to 0.8 millimeter in small ignition coils, and from 2 to 3 millimeters in large coils.

Although the efficiency is not greatly affected by the resistance of the primary circuit, it is good practice to reduce this resistance as much as possible in order to limit the heating, which may be injurious to the insulation, especially when the coil is intended for continuous service.

Among the modifications and improvements in primary windings, one of the most important consists in substituting for the single winding a core covered with several layers of wire, each layer entirely insulated from the others. The terminals of each layer are connected to a terminal plate where they may be inter-connected in series or parallel, so as to vary the coefficient of self-induction and the resist-

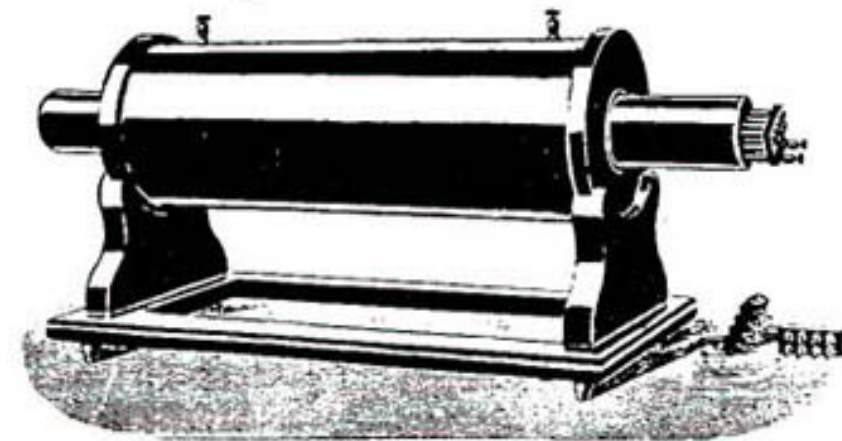

FIG. 55.

ance according to the needs of operation. Fig. 55 shows a construction recommended by Professor Walter to be used with a Wehnelt interrupter; there are four equal sections connected to eight insulated plugs. The following combinations may be obtained: Four coils in series; two in series and two in parallel; and four in parallel. In other models the connections are so arranged as to permit the cutting in and out of a greater or less number of coils.

The iron core is often formed of laminations. If the laminations are of equal breadth, the core will be rectangular. This makes it a little difficult to wind the primary, and much more difficult to wind the secondary, and,

therefore, is seldom used. Most often the laminations are made of different width and are assembled so as to form a section that is inscribed in a circle. In both cases the laminations should be insulated from each other. The use of sheets or laminations, instead of wire, gives a little better utilization of the space.

In models using a closed magnetic circuit the laminations are always used, because of the facility in construction. A model of this type is shown in Fig. 56. This construction has not found much favor.

28. **The secondary.**—As has been pointed out before, the secondary windings are made according to two different

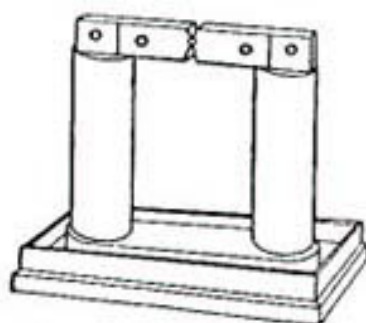

FIG. 56.

methods: In layers or in sections (Figs. 4 and 5). The layer winding is used only in very small coils; it is made by placing the coil in a lathe and winding the wire carefully so that the turns touch each other without crossing; after the winding of each layer of wires, a sheet of varnished or paraffin paper is inserted, so as to separate one layer from the other. Care must be taken to make the layers of paper several millimeters wider than the layers of wire. The winding being finished, the coil is plunged into a bath of hot paraffin or rosin, so as to fill all the spaces; it is afterwards removed and allowed to cool.

This construction is largely employed for small ignition coils; the winding is often made by machine, and some times bare wire is used; the machine in this case winds the turns so that they are separated from each other by an air space.

The section, or pie construction, consists in two operations; the winding of the pies and their assembly. The most commonly employed method up to within a few years, consisted in winding the pies in a bath of hot rosin, so as to fill the spaces between the wires and to glue them together. The apparatus employed is quite simple: It consists of a bobbin mounted on the arbor of a lathe or a wheel, below which is placed a metal basin filled with hot rosin (Fig. 57). The bobbin is generally composed of two brass disks having an external diameter equal to that of the pie; these disks are provided with a hole at the center through which a bolt is passed. A metal core having a diameter equal to

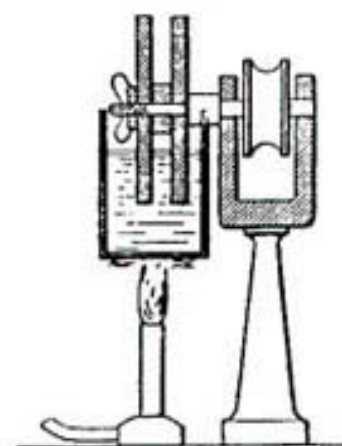

FIG. 57.

the interior diameter of the pies, and a length equal to the thickness which they should finally have is placed between the two disks; these three pieces are rigidly fastened together by a central bolt which completes the bobbin in which the wire is to be wound. Before commencing the winding, the disks and the core are covered with oiled paper, so as to facilitate the removal of the pies; on the core several turns of paper ribbon of an appropriate width are wound, or rings of cardboard cut to the proper diameter are used. The disks are covered with paper held on at the center by the core, and at the outside by a ring or by any other convenient method. The wire is placed on a reel in front

of the bobbin and its end is passed through a small hole made near the center of one of the disks. This being done, the basin of rosin is brought under the bobbin and raised until the bobbin is covered nearly to the axle. The winding is then commenced; it should be done slowly so that the rosin will have time to penetrate thoroughly. As soon as the bobbin is full, it is removed from the lathe and allowed to cool, and then the pie is finished. In order to prevent the unwinding of the interior wires, the core of the bobbin is often provided with a cardboard ring which remains glued to the wire in the form of a rigid circle.

In the old-style coils the pies were of nearly uniform thickness, varying from two millimeters to three millimeters. To-day, builders who still employ this method

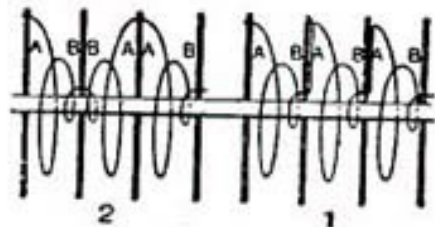

FIG. 58.

of manufacture, make the sections of extremely variable thickness; it is principally a question of convenience and equipment; it is impossible and useless to lay down any rule regarding this point.

In assembling the pies, insulating disks are inserted between adjacent sections. The connections between the consecutive sections may be made by joining the terminal from the interior of one to the exterior of the next (Fig. 58, 1); or by joining alternately the two interior terminals, then the two exterior terminals (Fig. 58, 2). In the first case the sections are assembled with the windings in the same direction; for instance, when the face, *A*, of the section is turned to the left in the winding machine all the faces, *A*, are turned to the left in assembled winding. In order to prevent contact between the wire running from

the center toward the outside of the section, two insulating disks are used, the wire passing between them. In the second case, the adjacent windings are reversed.

The disks employed vary with the builders; paper dipped in rosin, or varnished wood, glass and ebonite have been used. At present, each builder has his own preference. The essential condition to be met is that the disks have a sufficient dielectric strength to resist the maximum difference in potential, to which they are liable to be subjected. Paper disks are still used to a considerable extent. In preparing them, moderately strong paper is immersed in a bath of melted rosin; a sufficient number of sheets are piled up (in no case should less than two be used, so as to lessen the liability of failure on account of a small hole in the paper). The pile is then cut into the shape of annular disks, the inside diameter being the same as that of the coil, and the exterior diameter being a little larger than that of the coil.

The coils and the disks are assembled on a brass tube having a diameter equal to the internal diameter of the coils, then the terminals are joined and soldered. The assembled winding then has a length which is greater than it will be in the finished coil; the winding is put in an oven, and at a sufficiently high temperature a moderate pressure will squeeze out the excess of rosin which was used in impregnating the disks. The whole winding then becomes a compact mass.

The winding is then finished by adding two end disks of thick wood, to which are fastened the brass terminals of the secondary winding. The body of the winding is then wrapped with a temporary covering of pasteboard or thin metal, and receives a coat of hot rosin, which will completely insulate it.

This method of manufacture will give good results when it is carefully carried out, but it is costly and often causes dissatisfaction when used in making large induction coils. It is seldom used at present. The latest improvements consist mostly in new methods of manufacture.

Messrs. Rochefort & Wydts were the first to introduce important modifications in the construction of induction coils (French patent No. 265728, April 6, 1897). In the first model they abandoned the method of using pies, and returned to the layer winding, using one coil and fewer turns than was the usual practice. Furthermore, the entire coil was immersed in an insulating paste, so as to avoid fissures, which are often produced in the rosin and solid dielectrics, and also to avoid the deposit of carbon which results from the decomposition of liquid dielectrics. According to the patent, their insulation consists of a hot

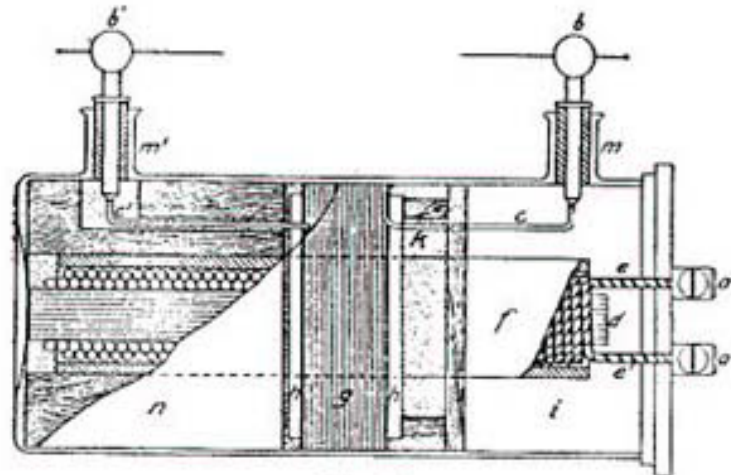

FIG. 59.

solution of paraffin in petroleum, which becomes a jelly upon cooling. The secondary winding, as seen in Fig. 59, is very short; it is placed at the middle of the primary at g, a position where the induction has a maximum value. The first coils made according to this system contained only 0.6 kilograms of wire, where equivalent coils of other models contained several kilograms.

At present, Rochefort has increased the number of elementary coils and connects them in series or parallel, according to the service for which they are intended. The attention of the reader should be called to a particular property of the layer winding, namely: The electrostatic

capacity between the interior layers of the primary winding is so large that the wire at the interior may be at a very low potential when the secondary is entirely insulated; from this it results that it is always necessary to connect the corresponding pole to the earth; this connection is necessary, as in wireless telegraphy, for example. Because of this property of the layer winding, Rochefort makes a practice of connecting the interior wire to the primary, and for this reason has given his coils the name "*Unipolar*." In order to prevent this property from being an inconvenience, this same builder joins two smaller coils, the two interior wires being connected together; the two terminals of the total coil then take up a potential equally elevated with respect to the earth, one positive and the other negative. This arrangement is equally symmetrical.

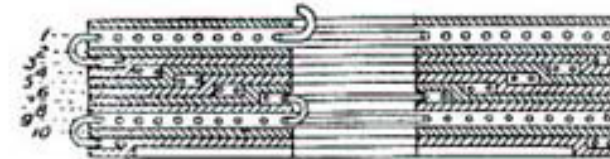

FIG. 60.

Based on a theoretically well founded idea, Klingelfuss has evolved a peculiar coil. It is well known that the difference in potential between any two convolutions of a coil increases with the number of convolutions which intervene in such a manner that in one pie the potential increases or decreases in the direction of the diameter, according to the direction of the current. If two pies connected at the center are placed facing each other, it is easy to see that the potential differences increase from the center toward the exterior; therefore, a disk of uniform thickness will be too thick at the center, and may be too thin at the exterior. In order to avoid this inconvenience, Klingelfuss (French patent No. 305,523, Nov. 19, 1900) constructs the insulating disks of gradually increasing thicknesses, thus returning to the extreme system used by Ritchie. His pies contain

only one thickness of wire. The winding itself is special; it is made by a machine not described in this book, and by means of which each turn is so formed that it cannot come in contact with a neighboring turn, the silk coverings of the wires do not even touch. A schematic drawing of the cross-section of the winding is shown in Fig. 60. A spiral plate, 1, being wound, is covered with an insulating disk, 2; several turns of the new layer, 3, are placed upon this disk, then the whole is filled with a specially formed disk, 4. Upon this are wound several other turns, which are in turn covered with an insulating disk, 5, and so on. Fig. 60 shows clearly how the number of insulating disks, that is the thickness of the dielectric, increases as the number of turns increases. The special machine referred to above, winds the wire in such a manner as not to require any soldering. Properly speaking, there are no pies or sections; the winding is continuous. This method of construction is very interesting, especially for very large coils; it has permitted Klingelfuss to build coils which give one-meter sparks and more and which will stand up perfectly under service.

Another constructor, Leslie Hiller, in an English patent (No. 5811, March 13, 1903) returns purely and simply to the Ritchie disk system: his coils is formed by flat spirals wound mechanically on disks of paper, and without destroying the continuity. There is naturally a great number of these disks; coils giving 25-cm. to 45-cm. sparks contain from 700 to 1200 disks, similar to the one shown in Fig. 61. As in the Klingelfuss system, the neighboring turns do not touch one another, in view of which fact the winding may be made of bare wire.

It has often been pointed out that in order to obtain a maximum effect with a certain length of wire, it is necessary to give the coil a profile which will be inscribed in the lines of force of the magnetic field (Fig. 62). In practice, since the secondary is always much shorter than the primary, the cylindrical form is equivalent, and there is no need of complicating the construction by these small de-

tails. The curve, $M = f(X)$, in Fig. 62, is obtained by measuring in different positions the coefficient of mutual induction between the primary and a pie, the diameters of which are d_1 and d_2 ; the ordinates, M , represent the relative values of the coefficients, and the abscissa the positions of the pie with respect to the iron core represented. This curve shows that for a secondary coil having a length equal to one-half that of the iron, the coefficient, M , varies but little.

Attempts have been made to give the interior turns of the pies a diameter increasing from the center toward

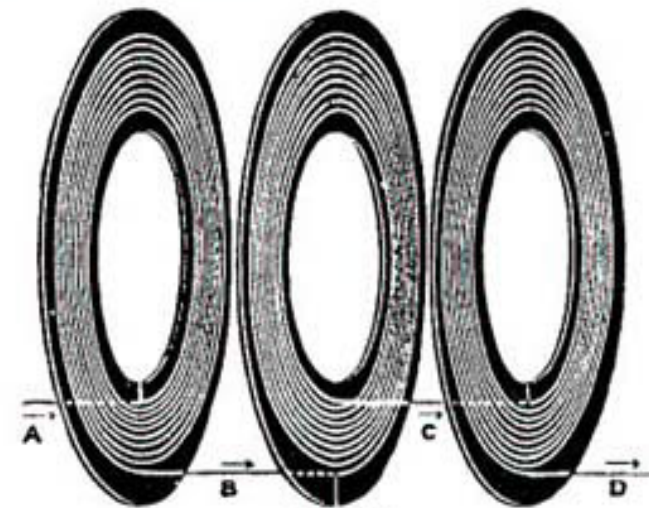

FIG. 61.

the extremities, so as to increase the distance between the primary and the secondary in proportion to the difference in potential which exists between them. It is well to know that the center of the coil is not necessarily at zero potential, and that dissymmetry in the discharge suffices to render the potential at one of the poles zero, or very near it; then the middle of the tube must resist a potential difference equal to one-half of the total e.m.f., and the extremity opposite must support double that amount. The theoretical coil would have a form as indicated by the cross-hatched portion in the upper half of Fig. 62, but this method of construction is very seldom used.

29. **Dielectrics.**—The insulation between the primary and secondary is very important. It is obtained in general by the aid of a glass, ebonite or micanite (reconstructed mica) tube. Oftentimes also for small coils, the tube is simply of cardboard, and in case the interior wire of the secondary is connected to the primary, the rôle played by the separating tube is simply that of a mechanical support.

Regardless of the dielectric chosen, the thickness must be proportioned to the length of sparks furnished by the coil—varying from a few millimeters for small coils, up to 20 or 30 millimeters for large ones.

Glass, which was principally employed at the beginning,

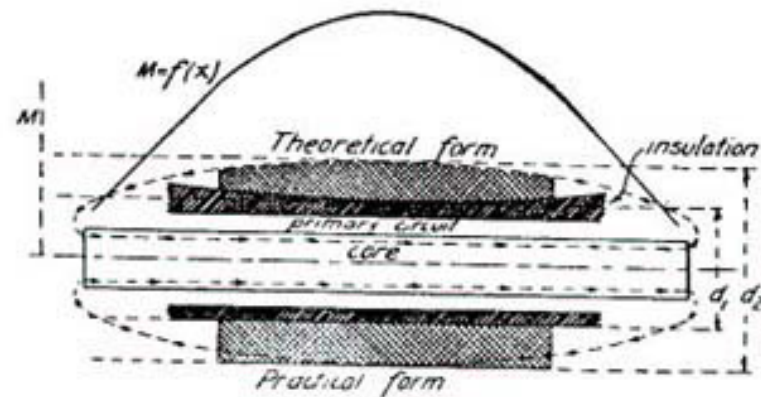

FIG. 62.

has been almost entirely abandoned; ebonite and micanite are now preferred. Ebonite, in addition to possessing good insulating qualities, is mechanically strong; but it is difficult to avoid defects in the mass, which will produce weak points. Micanite has, perhaps, a greater dielectric strength, but this is partly offset by the fact that the dielectric strength is affected by the action of ozone; therefore, it is necessary to completely envelope the micanite in another insulating material which will protect it from these effects.

There is generally play between the primary and the tube so that the primary can be easily withdrawn; but the secondary is nearly always glued to the tube by means of

an insulating material, such as rosin or paraffin, and the fastening should be such that there are no interstices in which sparks may form; with liquid or paste-like dielectrics the same precaution is necessary.

The exterior of the coil should be perfectly covered by an insulating layer more or less thick, according to the lengths of the sparks, so as to minimize leakage, which always takes place over the surfaces. It is equally important that there be no empty spaces between this layer of insulation and the wire. Many coils are at present enclosed in boxes filled with wax, paraffin, or rosin, or some pasty or liquid insulator; the box is sometimes filled in a vacuum.

The dielectric strength is not the only quality which the material used for insulating the exterior of the coil should possess. It should in addition possess the following qualities: Should not crack; should not melt under the action of moderate heat; should not possess a large temperature coefficient of expansion, and should not be hygroscopic. There is no really perfect insulator; the rosins and the paraffins possess in part the requisite qualities, and each builder has his own preferences prompted by his experience and the conditions of manufacture.

30. **Condensers.**—Condensers used with induction coils are made up of sheets of tin-foil separated by sheets of some dielectric; this is most often varnished, rosined or paraffined paper, varnished or paraffined silk, or rubber, caoutchouc, and sometimes mica. It does not appear that the quality of the dielectric has much influence on the efficiency of the coil. The only thing required, is that the thickness of the dielectric be sufficient to resist the differences in potential, often very great, to which the condenser is subjected (see Chapter III); this thickness should be very much greater when the coil is intended for continuous service, because it should not be forgotten that condensers become perceptibly heated in operation, and that the dielectric strength diminishes rapidly when the temperature increases.

The common method of constructing condensers is as follows: Sheets of paper are cut to the required dimensions, as are also sheets of tin-foil; the sheets of tin-foil are made from 1 to 2 centimeters narrower than the sheets of paper, but very much longer. The number of sheets of paper to be inserted between the tin-foil varies with the power of the coil and the thickness of the sheets themselves, but there should always be, at least, two thicknesses, so as to avoid the breaking down of the condenser due to an unseen fault in the paper. The sheets of paper are varnished or paraffined in advance or are used dry. Place on the table the sheets of paper which are to form the dielectric, then, on top, a sheet of tin-foil.

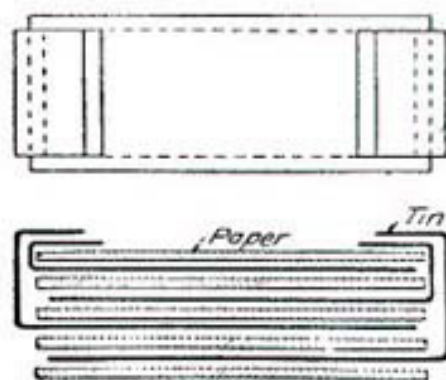

FIG. 63.

being careful to leave an equal border of paper on three sides, the tin-foil projecting from the foreside. On this sheet place another layer of papers, lining them up with the first, then another layer of tin-foil with its end projecting from the opposite side, etc., until the condenser is completed. Then the whole mass is placed in an oven, where it is boiled in rosin or paraffin; finally, while still hot, it is pressed into a firm mass. The extremities of the sheets of tinfoil which extend beyond the two ends, are bent back upon the ones above (Fig. 63), and contact is established by aid of springs which press against these parts; or, better yet, the extremities are bent back upon themselves and soldered to wires, so as to establish a better contact.

Nowadays, condensers are often subdivided and provided with terminals which permit the use of sections separately or in groups, so as to vary the capacity.

The subdivision can be made in equal parts or according to any progression. The best combination to adopt, because it gives the greatest number of combinations, is the binary series: 1, 2, 4, 8, 16, etc. With four sections this series gives all the combinations from 1 to 15, while the decimal series: 1, 2, 2, 5 gives only from 1 to 10, and equal sections give 1 to 4. The grouping of sections is

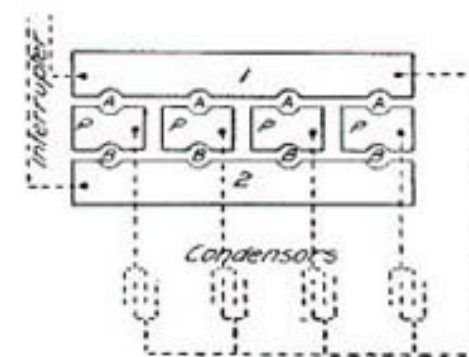

FIG. 64.

always made in parallel; the terminals are formed in different ways. In the model shown in Fig. 64, all the sections have one of their terminals connected to a copper strip, 1; the other terminals are connected to blocks, *P*. A plug placed in *B* connects the corresponding section to the circuit; at *A*, on the contrary, the section is short-circuited. The plugs which are placed in the holes, *A* and *B*, are sometimes replaced by sliding contacts pivoted on blocks, *B*, and coming in contact with 1 or 2.

From what we have seen of the rôle played by the condenser, it is easily understood that it is very desirable to be able to adjust the capacity.

31. **Dimensions and proportions.**—If we knew the law of disruptive e.m.f. as a function of time for a given interrupter and the law of the secondary discharge, it would be possible to calculate a complete induction coil; the cal-

ulation would not differ greatly from that required for a commercial transformer, but since these facts are lacking, it is but a delusion to make the calculation, and one must have recourse to empirical methods in determining each design.

Nevertheless, there are some indications which may be deduced from the theory and requirements of construction. First of all, the length of the secondary coil cannot be less than the length of the spark which it is desired to obtain, unless a construction analogous to that of Rochefort is used. The length of the body of the coil is then determined.

Furthermore, it is known that the efficacy of the pies decreases from center toward the extremities and that for the proportions generally used, the iron core should be at least twice the length of the body of the secondary coil. The ratio of the length to the diameter should be between 10 and 15 if the best results are to be obtained.*

*It has long been the custom to specify a certain ratio of core-

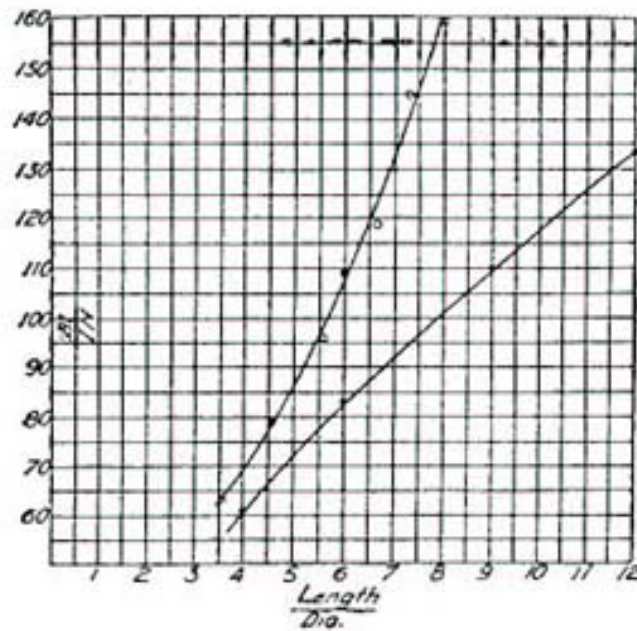

FIG. 64A.

length to core-diameter, when the most favorable results are to be obtained from an induction coil with an open magnetic circuit. Some

Therefore, we can write,

Length of body of secondary $> l$;

The length of iron core $= 2l$;

Diameter of core $= \frac{2}{D}l$ to $\frac{2}{15}l$;

wherein l is the length of the spark.

These dimensions can be altered afterwards if necessary.

Primary windings should be made of wire of such size that the heat, $I^2 R T$, liberated should be radiated without danger to the coil. It is good practice to work the primary copper at a mean current density of from 1 to 2 am-

per inch, time ago, the writer attempted to establish some definite relation between the flux density in the core and this ratio. Results of tests on two sets of cores were plotted with the ratio of core-length to core-diameter, as shown in Fig. 64A. The black points represent a line of cores one inch in diameter, and of various lengths, while the white points are for a line of cores four inches long, and of various diameters. It is evident that there is no simple relation between the flux density per ampere-turn per inch-length of coil, and the

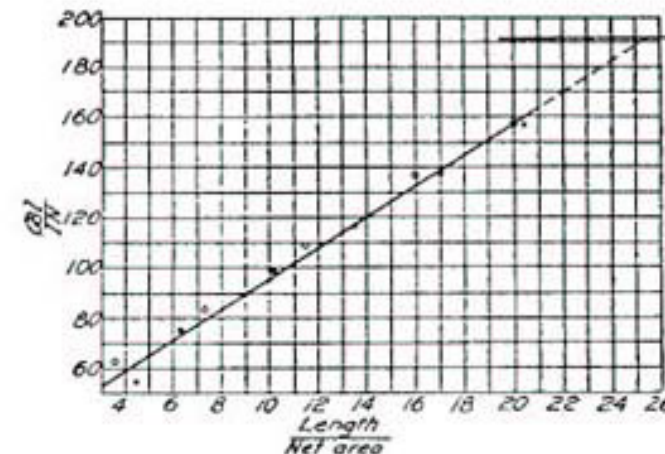

FIG. 64B.

ratio of core-length to core-diameter. Fig. 64B shows results from the same tests plotted with the ratio of core-length to net core-area. It is interesting to note that under these circumstances all the points arrange themselves along a given straight line. The test data were taken from an article published in the *Electrical World*, December 14, 1907, by Professor F. W. Springer. O. A. K.

peres per square millimeter; but the cooling being almost nil, the total quantity of heat liberated should be quite small. This necessitates in large coils, or where the length of wire is considerable, the increasing of the diameter of the wire so as to obtain a total resistance as small as possible. It must be remembered that hysteresis plays an important rôle in the heating of large coils, and it is, therefore, necessary to reduce that part of the heating which is due to copper loss.

The number of turns on the primary varies with the value of current to be employed; it is always good to reduce this number, so as not to require too large a number for the secondary. An important consideration enters here: The energy stored in the coil which is a function of the number of turns. The necessity of increasing the volume of the iron with a length of spark, requires an increase in the power of the coil. Experience shows that the iron is worked at a mean induction of about 6000 gausses; this induction is close to that obtained in practice when the magnetizing force is about 100 gilberts:*

$$\mathfrak{C} = \frac{0.4 \pi N I}{l'}$$

the length l' of the primary coil is generally from 0.8 to

*A given ratio of core-length to core-diameter can correspond to any ratio of core-length to net core-area.

If the values of \mathfrak{C} and \mathfrak{B} assumed above are expressed in English units, we have

$\mathfrak{C} = 254$ gilberts per in., and $\mathfrak{B} = 38,700$ lines per sq. in. and from

$$\mathfrak{C} = \frac{0.4 \pi N I}{l} = 254,$$

we have

$$\frac{I N}{l} = \frac{254}{0.4 \pi}$$

and

$$\frac{\mathfrak{B} l}{I N} = 191.56,$$

Assuming this last expression to be constant for coils whose core-length is equal to from 10 to 15 times the diameter, and plotting

0.9 that of the iron, From this equation, we can get the practical value:

$$N = 64 \frac{l}{I},$$

the length, l , of the iron being expressed in centimeters, and the current value, I , in amperes.

Under these conditions the coefficients of self-induction of the primary winding, the core having a ratio, $\frac{l}{d}$, between 10 and 15, may be expressed as a first approximation by,

$$L = 80 N^2 d \times 10^{-9};$$

N being the total number of turns when the diameter, d , is expressed in centimeters, while the coefficient of self-induction is given in henrys.

The number of primary turns being determined, it is next necessary to obtain the number of secondary turns. There is no rule for determining this number. As a principle, it can be assumed that the ratio between the number of turns (coefficient of transformation) increases with the length of sparks. In accordance with the known law, that the ratio of the number of turns is also that of the e.m.fs. of induction. Therefore the difference of potential to which the dielectrics of the primary and condenser are submitted, increases with the disruptive voltage in the secondary, and it is necessary to increase the thickness of these dielectrics if the coefficient of transformation is left

this value with the ratio of core-length to net core-area, we get a straight line parallel to the x -axis (Fig. 64b.) This line intersects the line, found by experiment, at a point corresponding to a ratio of length to area of about 1 to 25.

From this it appears that the equation given by the author cannot be applied to all coils whose core dimensions fulfil the requirement that the core-length be from 10 to 15 times the diameter. However, it is safe to say that the results will be approximately correct when the ratio of core-length to net core-area lies between

$$\frac{L}{A} > 24 < 27. \quad \text{O. A. K.}$$

constant. Furthermore, the e.m.f. of self-induction increasing the operation of the interrupter, is less stable, the sparking is greater and absorbs a greater amount of energy.

The coefficients of transformation employed by different builders vary greatly. Some, like the Allgemeine Elektrizitäts Gesellschaft, appear to have been guided by the considerations given above; others, on the contrary, considerably reduce these coefficients. The following table shows the great variance of opinion on this subject.

TRANSFORMATION RATIOS FOR DIFFERENT LENGTHS OF SPARK.

Length of sparks	A. E. G.	Carpentier	Klingelfuss	Rocheport
15 cm.....	160	108	"	"
20.....	180	157	"	"
25.....	210	163	"	115
30.....	240	183	"	100 a 150
40.....	300	150	"	"
50.....	150	180	"	"
60.....	420	144	"	"
70.....	500	"	"	"
100.....	"	"	107	"

The coefficients of the A. E. G. appear high when compared with those of the other builders, but it is evident that if one could obtain windings with a great number of turns having a lower resistance, and at the same time preserving sufficient insulation on the wire, it would be advantageous to employ this construction; unfortunately, the above conditions are contradicted, and there is reason to fear that with a great number of turns the wires are crowded, and that sparks form between the individual turns.

Whatever the truth may be, the figures in the preceding table show that for coils equally well constructed and enjoying a well established reputation, the coefficients of transformation are entirely different, which proves the uselessness of calculation in the design.

The diameter of the secondary wire is generally quite small, varying from 0.15 to 0.20 millimeters; rarely is use made of larger wire, and it does not seem that much is gained by increasing the size; it is preferable for a given volume to increase the thickness of insulation, or the space between the wires.

In determining the thickness of the insulating tube between the two circuits, the same indecision reigns. The thickness should naturally increase with the length of the sparks—it is scarcely possible to give a rule on this subject; experience is the only guide. In addition to the dielectric strength, defects in manufacture must be taken into account and allowed for. Below is given the dielectric strength of a few substances as determined by Thomas Gray; these figures represent the e.m.f. in kilovolts necessary to puncture one centimeter of the substance. It should be remembered that the dielectric strength decreases as the thickness increases.

Glass, thickness, 1 mm.....	Dielectric strength 285 kv. per cm.
" " 2 ".....	" " 253
" " 4 ".....	" " 200
" " 6 ".....	" " 168
Ebonite, one thickness, 0 mm, 93	" " 538
" two thicknesses, 1 mm, 86	" " 434
Micanite, thickness, 1 mm.....	" " 400

In comparing these figures with the disruptive voltages given in other places, one can obtain an idea of the dimensions to be adopted. Practically, the insulating tubes employed for medium sized coils, giving 25 to 45-centimeter sparks, have a thickness of several centimeters.

32. Types of induction coils.—For a long time the exterior appearance of induction coils has remained about the same as was established by the first builders: A cylindrical body terminated at two ends by glass disks and covered with a sheathing of ebonite (Fig. 65); this cylinder was mounted on a base containing the condenser. Since the field of application has become considerably extended, the construction has become robust, looking less like the

forms used in physical laboratories. At present in France a great number of builders place the coils in rectangular boxes filled with rosin or paraffin. The terminals are

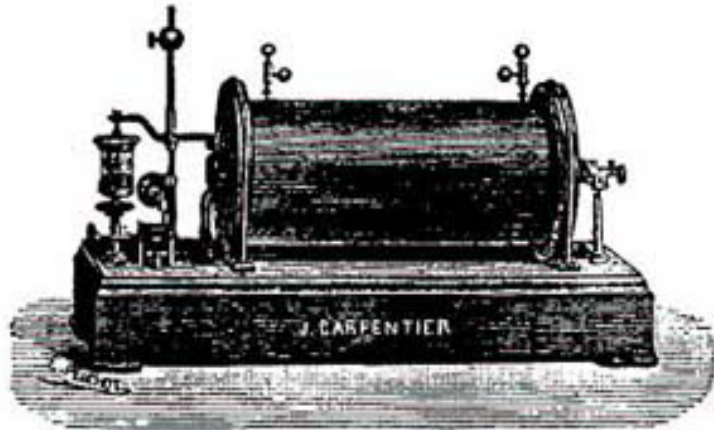

FIG. 65.

often mounted on ebonite columns. The primary coil is generally about the length of the box, it projects slightly

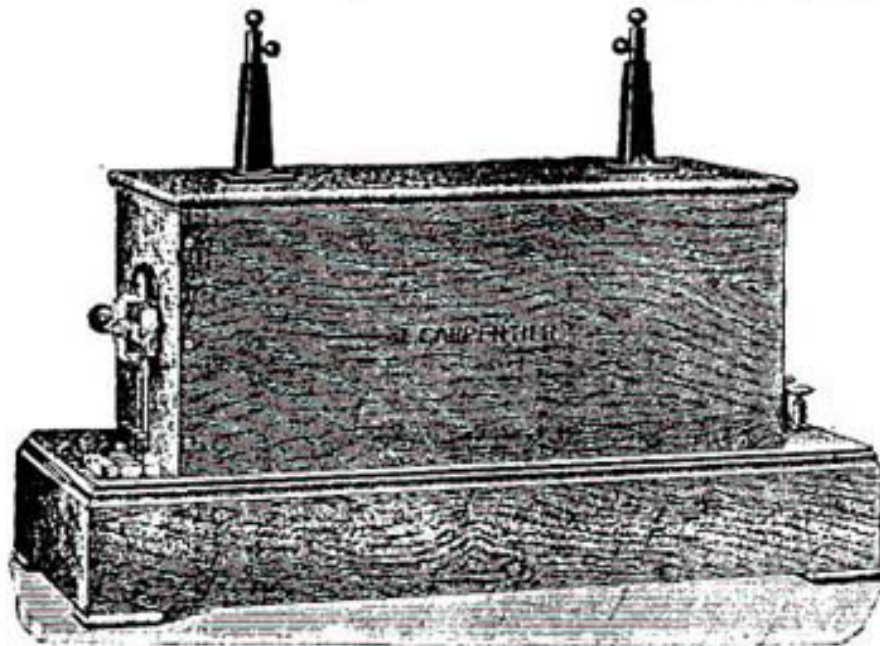

FIG. 66.

at each end. These boxes are sometimes mounted on a base containing the condenser, and the interrupter is placed

at one side (Fig. 66). The use of the Wehnelt interrupter, which design requires no condenser, has led to a construc-

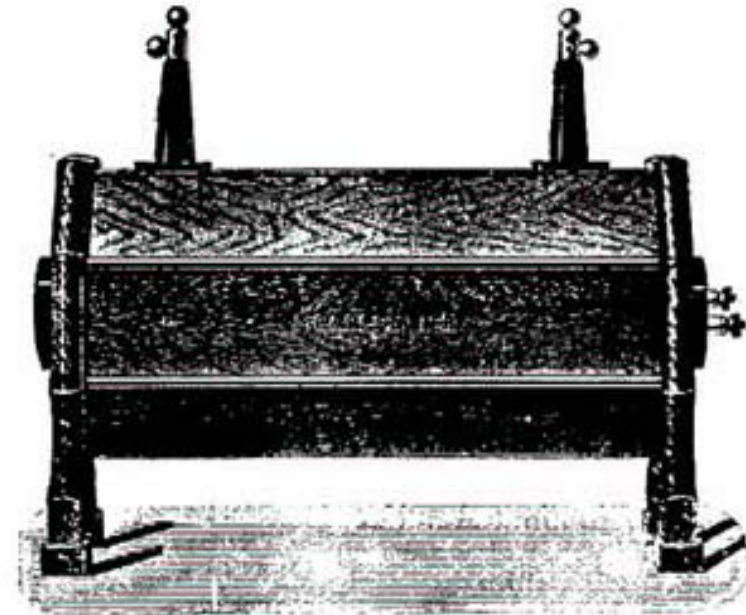

FIG. 67.

tion without a base, such as shown in Fig. 67. The form generally used in Germany may be characterized by Fig.

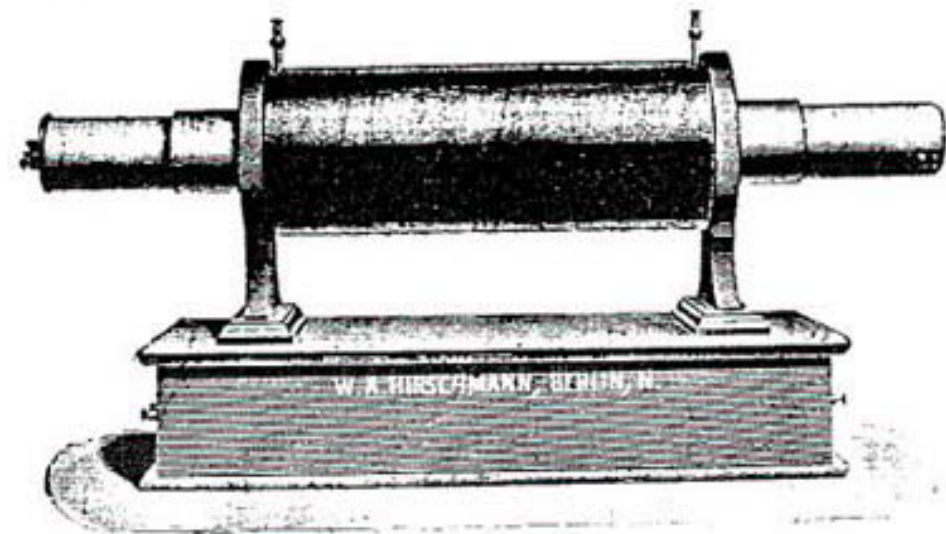

FIG. 68.

68. The primary is very long, it extends considerably at both ends; it is covered as all other parts of the coil with

a sheathing of ebonite. The secondary coil has a length about equal to that of the sparks, and is supported by two

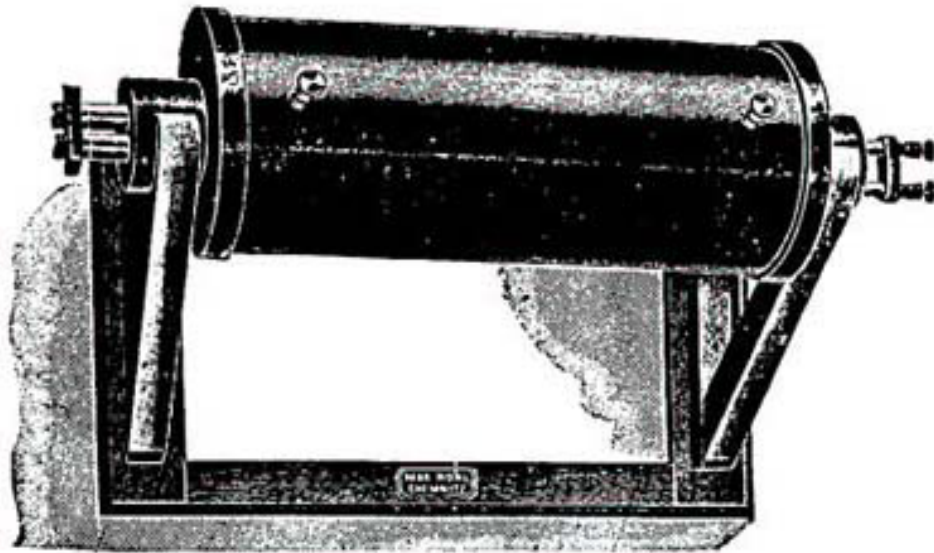

FIG. 69.

specially formed disks which rest upon a base. A construction which is often advantageous is shown in Fig. 69.

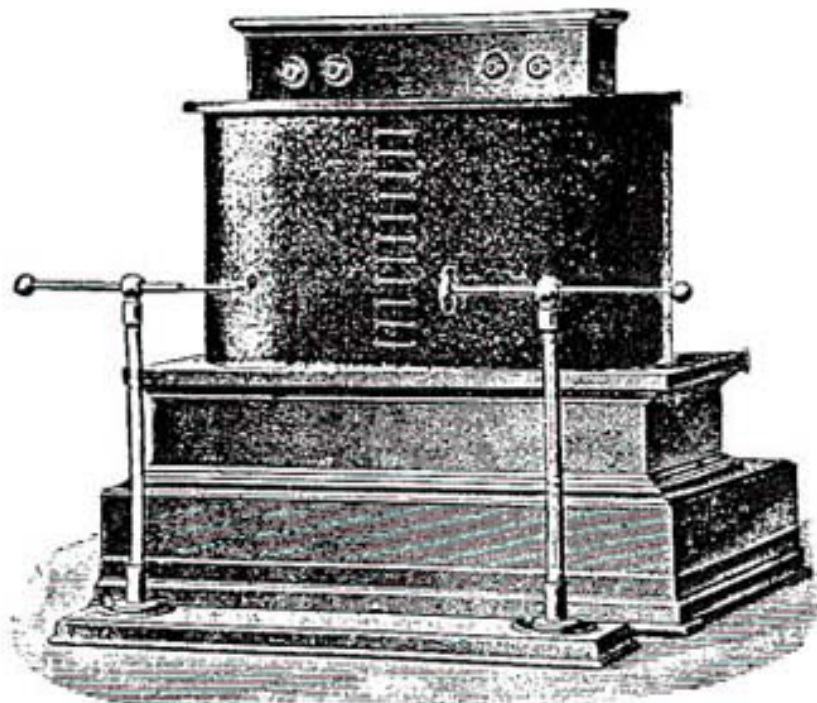

FIG. 70.

It consists of supporting the induction coils on two brackets fastened to the wall.

The English and American induction coils are combinations of those given above.

As can be seen, the form which a coil may take is not at all fixed, and it is possible that wireless telegraphy, which is one of the principal commercial fields of application, will

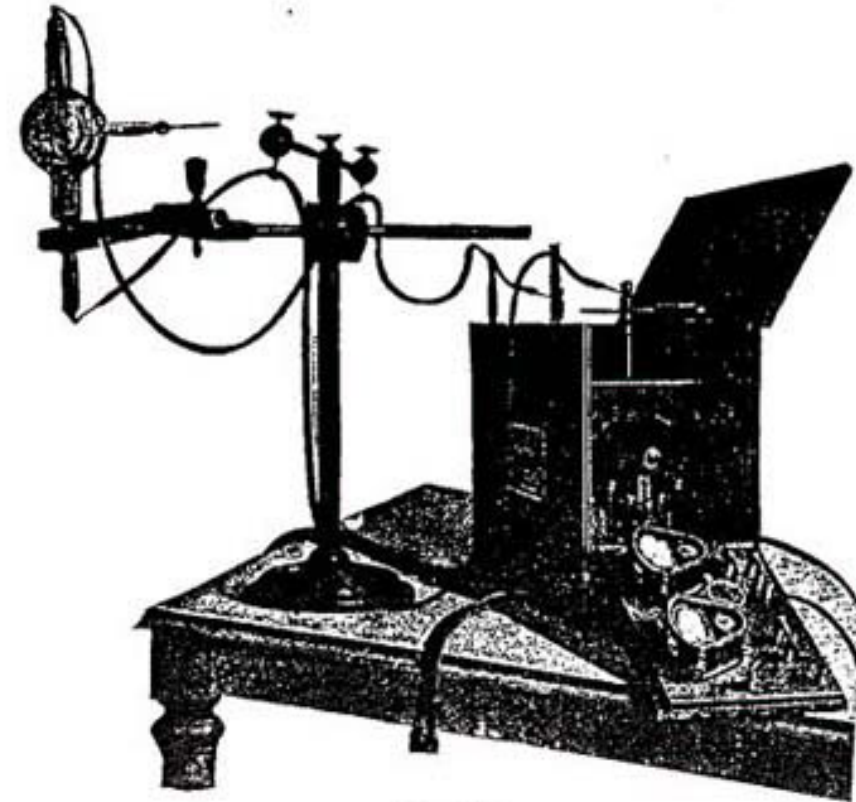

FIG. 71.

conduct to coils of more robust and practical construction; which will more nearly resemble the commercial transformer.

Among the coils which may be considered as special is the vertical type represented almost entirely at present by the Rochefort coils (Fig. 59) and the closed-circuit type made by Klingelfuss (Fig. 70).

The coils used in radiography must often be arranged

for transportation of the complete outfit; several models have been designed for this purpose. The coils are reduced to the smallest possible dimensions and enclosed in a case which contains also the greatest part of the necessary apparatus for operating the tubes (Fig. 71).

Finally, we may close this summary by saying a few words concerning the small medical induction coils. The general form of these instruments is well known; one or two cylindrical coils of small dimensions provided with spring interrupters are placed in a box with the accessories, such as dry-battery electrodes, salt, etc. Condensers are not used with these coils. The terminals are so placed that the electrodes can be connected to the primary or the secondary. The regulation of the value of the secondary current is made either by changing the relative position of the primary and secondary, as in the apparatus designed by Dubois-Reymond, or by inserting to a greater or less degree, the metallic tube between the two circuits, and in this manner screening the effect of the primary and secondary.

CHAPTER VIII.

INTERRUPTERS.

33. **Solid contact interrupters.**—The hammer interrupter of Wagner & Neef, such as was used with the first coils, is to-day almost completely discarded, but models derived from this type operate very satisfactorily when their dimensions are properly proportioned. The general form of these interrupters is shown in Fig. 72; a spring blade made of brass or steel, carries at one extremity, a mass of iron or hammer, *M*; this hammer is placed before and a short distance from the core, *F*, of the coil. A platinum point, *p*,

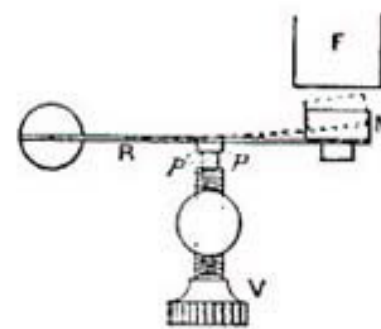

FIG. 72.

p, is riveted to the spring, and makes contact with *p'*, which is also of platinum and carried at the end of the thumb-screw, *V*. When the screw is in contact with the spring, the coil being connected to the source, the hammer will be attracted to the core. This separates the contacts at *p* and *p'*, thus opening the circuit. The magnetic attraction ceases, the hammer is returned to its initial position by the spring, thus again restoring the continuity of the circuit and the phenomena is repeated, and in this way the vibratory movement is given the hammer. The

amplitude and the frequency of the vibration are regulated by the mass put in motion, the elasticity of the spring, the value of the current, and the pressure of the screw against the spring.

The sparks which are produced by the interrupter, roughen the surface of the contact; they sometimes melt and freeze together, thus stopping the operation of the coil. d'Arsonval has endeavored to correct this defect by giving one of the contacts a continuous rotating movement, in this manner the small projections produced by the sparks are regularly distributed, and the surface of the platinum remains intact, thus adding greatly to the reliability of operation. The vibrating spring is as usual, provided with a platinum point, but the screw is furnished with a platinum cylinder of greater diameter. The contact is produced at the circumference of the cylinder in such a way that revolving the cylinder slightly upon its axis, the point of contact is constantly renewed. The movement is given to the cylinder by a small auxiliary electric motor.

In interrupters of the Neef type, the rupture of the circuit takes place at a point on the vibrating blade where the amplitude is less than at the hammer, and the spring is bent before the rupture takes place, because of which the speed of separation at the contact is not very great. For this reason the limit is soon reached, because of the sparking of the interrupter which prevents the use of this type with coils giving long sparks.

The Deprez interrupter (ISSI) is a very important improvement. The fundamental idea was to maintain a closed-circuit by pressure at the contacts, such that the rupture could not take place before the current had attained the necessary value. In the Neef interrupters, the vibrations of the hammer are almost entirely regulated by the elasticity of the spring and the mass of the hammer, therefore, if the contact is not well made, the rupture is produced at a given moment, regardless of the value of current in the primary and the sparks produced in the secondary are, therefore, irregular.

One of the latest forms of the Deprez interrupter is shown in Fig. 73: M is an iron blade which oscillates about the axis, O ; the spring, R , deflected by the screw, V_2 , presses the blade against the contact screw, V_1 ; two platinum contacts, a and b , one fastened on the blade, the other at the screw, V_1 , make the electrical contact between the two pieces; the blade, M , is entirely separated from the rest of the interrupter, it is connected to the primary of the coil. The electricity enters by the screw, V_1 , passes from V_1 to M contacts, a and b , traverses the primary winding and returns to the source. The core, F , attracts M , and at the moment when the electromagnetic attraction is sufficient to overcome the tension of the spring, R ;

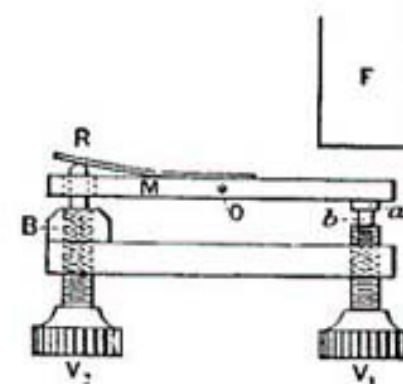

FIG. 73.

the blade, M , is drawn toward F and the rupture takes place. The circuit being broken, the spring returns the blade to its original position, thus closing the circuit. It is easily seen that this interrupter permits an easy regulation of the current value, corresponding to which the rupture will take place, by adjusting the screw, V_2 , which modifies the tension of the spring. For a given adjustment, the rupture will always take place at about the same current value, regardless of the e.m.f. of the source, but the frequency of the interrupters depends on the voltage increasing with it. It is also well to know that the system is not free to oscillate and has no natural period; its period may vary over a large range. This interrupter

gives excellent results in experiments of short duration in which it is possible to look after its operation. In prolonged experiments, the current value must be greatly reduced, because the sparks produced at the points of rupture will often cause a freezing of the contacts, and thus stop the interrupter.

Theory shows that the essential condition which should be fulfilled by an interrupter for induction coils is to produce the quickest possible rupture—that is, right at the start to have a very high speed of separation at the contacts, so that the spark at the contact will encounter a high resistance.

This requirement has led several builders to produce the rupture by a shock, allowing the hammer to strike a spring in such a way as to very rapidly separate the two contacts. This method is used in the interrupter of Watson & King (French patent No. 266, 499, 1897).

The atonic interrupter of Carpentier acts in this manner, and, furthermore, has no natural period of vibration; it is perfectly atonic. It is at present one of the best solid contact interrupters made. It consists (Fig. 74) of a strip of soft iron, *P*, resting in a triangular slot of a block of iron: a coil spring, *R*, placed parallel with *P* pulls this strip against a blunt ended screw, *B*, the end of which is made of ivory. The tension of the spring, *R*, is regulated with the thumb-screw, *M*. Because of the position of the spring, *R*, the displacement of the spring, *P*, toward the core causes no appreciable variation in the tension; consequently, as soon as the magnetism is sufficient to overcome the tension of the spring, the strip, *P*, is attracted much more rapidly than is the case when the force of the spring increases with the displacement. The electric contact is established between the elastic blade, *L*, and a platinum tipped screw, *C*. If by an adjustment of the screws, *B* and *C*, a suitable distance between *L* and *P* is established, *P* will strike *L* at a moment when its speed is quite high; and since the inertia of *L* is very small, a very rapid separation of the contacts, *a* and *b*, will take

place. The return of *P* after the rupture, or the re-establishment of the circuit, depends on the tension of spring *R*, also that of spring *L*. Experience shows that it is possible to obtain a duration of open-circuit which is very short in comparison with the period of the interrupter. The current value at which the rupture is produced depends on the two factors given above, but particularly on

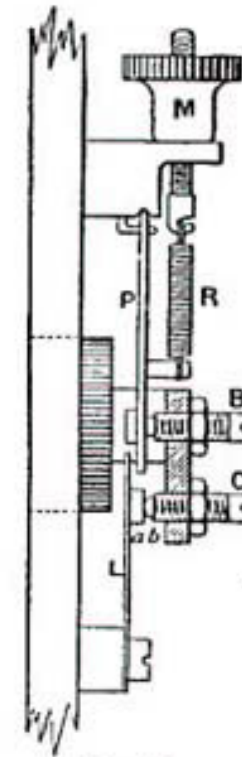

FIG. 74.

the first. If the current value is once adjusted, it will remain extremely constant.

This interrupter is really atonic and can be used at any speed desired; it may, for example, be synchronized perfectly with alternating current. Another interesting property of this interrupter is, that it always produces the rupture at a given time after the closing of the circuit; this time is that which is necessary to attain a given current value. We will see, when speaking of internal combustion engines, the importance of this property.

All interrupters described above operate with quite low voltages, 25 to 30 volts at the most. Above this point a veritable arc is established between the contact points, which will burn them, or at least, will cause the coil to operate poorly, or stop it entirely. For voltages above this, it is necessary to make the break in a non-conducting

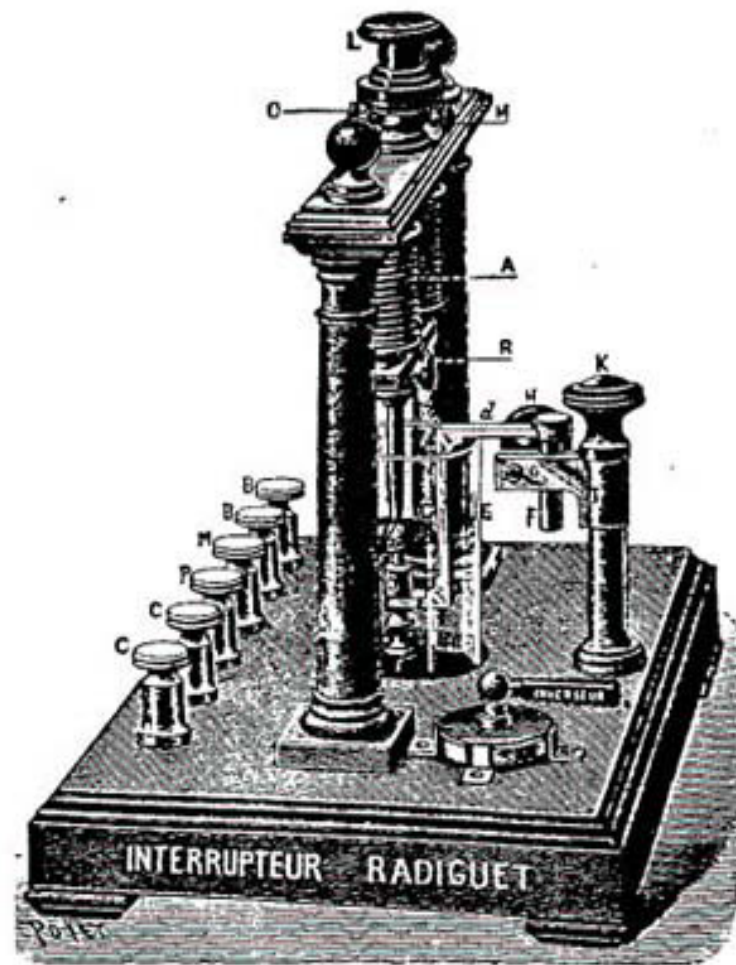

FIG. 75.

liquid, so as to smother the arc. This is a method generally employed in the mercury interrupters, and has been applied to some solid-contact interrupters. Among the interrupters of this class, we can cite three different models.

In the Radiguet interrupter (Fig. 75), the arc is produced

between two pieces of copper. The upper piece is coupled to the armature of an electromagnet by an elliptic spring, *C*, similar to those used on carriages. The electromagnet being excited by the primary current of the coil, the armature is raised and breaks the contact between the vertical pieces and the copper block, *D*, supported by the piece, *d*. The current being ruptured, the armature and the upper contact piece fall back, re-establishing the contact. Because of the spring, the vertical piece presses on the block during a variable fraction of the period, and the rupture is made when the speed of the armature has attained a considerable value, thus assuring a sudden separation of the contacts. Regulation is made by adjustment of the lower contact through its support, *d*.

The Lecarme & Michel interrupter (1902) rotates. It consists of four brushes of thin brass carried on a vertical shaft. When this shaft turns, centrifugal force opens the brushes and causes them to rub against fixed copper contacts with a pressure which increases with the speed. During the rotation, while the brushes are in contact with the pieces of copper, the petroleum which fills the receptacle is compressed. As soon as the brushes pass the contacts, the petroleum passes out quickly and assists in smothering the spark at the rupture at the same time it cools the contacts.

In Contremoulins & Gaiffe's interrupter, (Fig. 76) the part which turns, is composed of a copper drum similar to a dynamo commutator. This drum carries four insulating pieces in such a manner as to form two large segments and two small ones. Two brushes, formerly of carbon, but at present of copper, rub against the commutator. One of the brushes is fixed, the other movable, and it may be adjusted through an angle of 110 degrees about the axis of the commutator. When the two brushes are brought near each other, they are in contact with the same segment for a considerable portion of the revolution. On the other hand, when they are on the same diameter, they are constantly insulated from one another; between

these two limiting positions, it is easy to see that by the displacement of the movable brush, the duration of the contact can be varied.

34. **Mercury interrupters.**—In order to increase the power of the coil, it is necessary to increase the voltage of the source, so as to facilitate the establishment of the current, which permits an increase in the frequency of interruption, or the current value at the instant when the rupture takes place. Mercury interrupters are almost indispensable in this case.

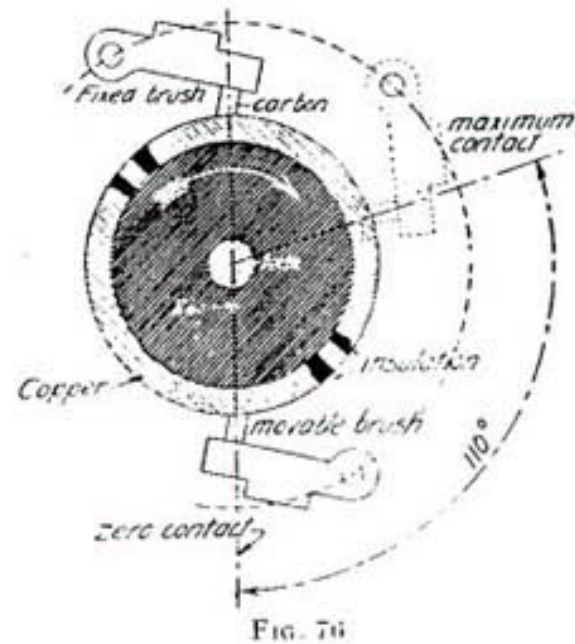

FIG. 76.

The Foucault interrupter in its classic form (Fig. 77) is composed of a horizontal beam, *F*, supported by a vertical spring, *K*. The beam is provided at one extremity with a soft iron block, *M*, and the other one with a rod, *A*, ordinarily terminated by a platinum point. The second rod, *B*, similar to *A*, is placed nearer to the spring. The two rods plunge in glasses of mercury covered with alcohol or water. Beneath the iron block is placed an electromagnet, *E*, operated by a separate battery. When the beam is lowered on the side toward the glasses, the two

rods plunge in the mercury, or are immersed in the mercury; the one, *A*, at the end completes the circuit of the coil, while the second one, *B*, completes the circuit of the electromagnet; the latter attracts the soft iron of the beam and flexes the spring, *R*, causing the two rods, *A*, and *B*, to be lifted out of the cups of mercury, thus breaking the circuits. The beam is then returned to its original position by the spring, *R*, and the cycle repeated. The movement of the beam is thus maintained electrically; the duration of the oscillations depends on the stiffness

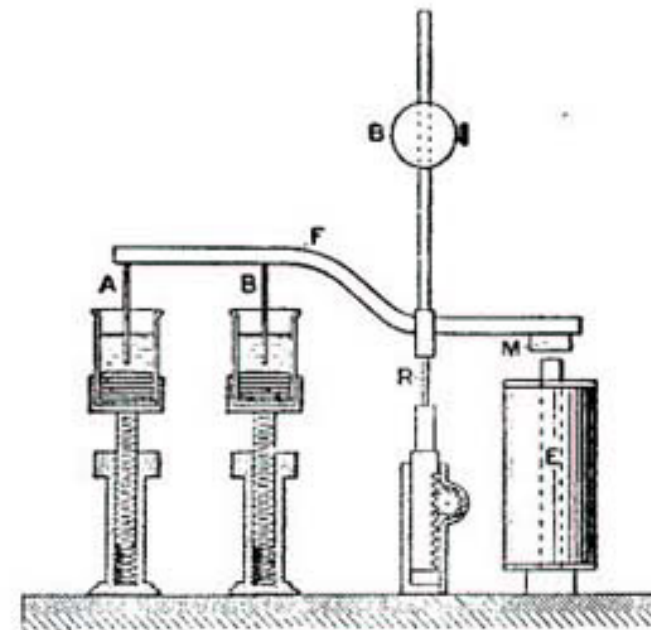

FIG. 77.

of the spring, the inertia of the beam, which may be regulated with the ball, *C*, and also on the depth of the immersion of the rods in the mercury. This interrupter may be regulated by raising the entire beam system with the aid of a rack and pinion, and raising or lowering the cup, *B*. The most important regulation is that of the cup, *A*, which is connected to the coil, because it permits the variation of the duration of the contact; this arrangement, which will be recognized in all the mercury interrupters, is of capital

importance. Because of it, it is possible to regulate in each case the duration of contact, so as to obtain a maximum effect with a minimum amount of energy.

Often the interrupter is reduced to a walking beam and a single cup, the whole being placed on the same base as the induction coil, and the iron core of the coil being used to attract the soft-iron armature (Fig. 65).

The Foucault interrupter has been practically abandoned: it has been greatly modified in order to adapt it to high speed and to the rupture of large values of current, and to the high voltage employed nowadays.

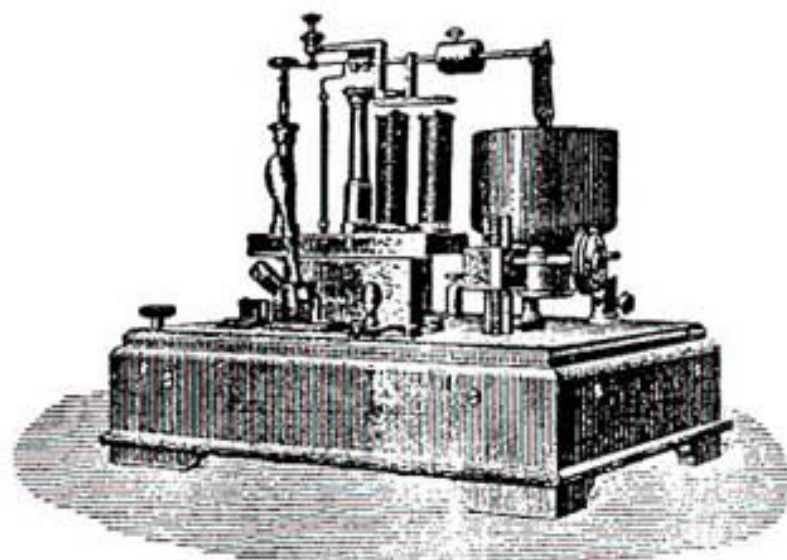

FIG. 78.

The plunging rod of the Foucault interrupter enters obliquely into the mercury and whips the liquid, forming an emulsion of the mercury with the insulating liquid, and in this way constantly changes the adjustment. In all the present forms of the mercury interrupter, attempts have been made to remedy this defect, either by guiding the plunging contact, or by giving the beam such length as to render the movement practically in a straight line.

In the Rochefort interrupter (Fig. 78) the copper blade which plunges in the mercury is connected to the beam

through a thin strip which permits it to follow the beam, at the same time varying the angle. The electromagnet, attracting the armature and a platinum pointed auxiliary contact, gives the beam an oscillatory movement, which can be regulated at will. During the vibration, the plunging contact tends to deviate from a straight line because of the centrifugal force, but the resistance of the liquid against its large surfaces is sufficient to maintain it in an almost straight line; the liquid, therefore, plays the rôle of guide.

In the large model of the Villard interrupter (Fig. 79) a beam with a large radius is employed. The plunging contact is carried by one of the branches of a tuning-fork.

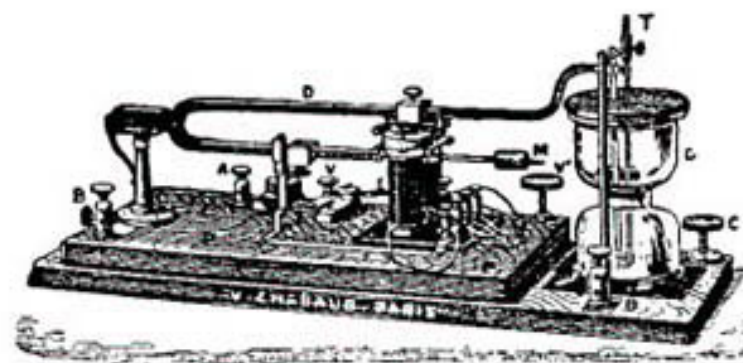

FIG. 79.

This same branch carries the soft iron armature, which plays in front of an electromagnet; the action of the latter tends to draw the branches of the tuning-fork together in such a manner that they are set into vibration and open the circuit at equal intervals. The counter-weights placed on the branches permit the tuning of the two branches, and within certain limits, permit the regulation of the vibration number. The cup is made smaller at the center where the surface of the mercury is situated, so as to avoid oscillations of the liquid; similar arrangements are found in most other mercury interrupters. Finally, to facilitate the renewal of the mercury, the base which carries the tuning-fork and the terminals is hinged

on the left side, so that the whole can be lifted, permitting the removal of the cup. A great improvement in the interrupters of the plunging-contact type, consists in moving the contact by an electric motor, and transforming the rotary motion into a straight line, as is done in the steam engine. This arrangement, which seems to have been brought forward in Germany, is to-day employed by all builders. The electric motor has the advantage of being easily regulated as to speed, and gives a constant amplitude, irrespective of the speed. The interrupters of this type are certainly among the most practical; above all for operation on lighting circuits. On the other hand, they do not readily lend themselves to high speeds, because of the inertia of the parts which must follow the alternating movement. The tendency of the mercury to follow the contact also limits the speed in such a manner that it is scarcely possible to utilize these interrupters at a speed above 30 or 40 interruptions per second.

Another inconvenience which is common to mercury interrupters is the rapid pulverization of the mercury, which is produced by the motion under the action of sparks. The mercury forms a gray colored paste composed of very small globules of metal enveloped in a black powder, due to the decomposition of the insulating liquid by the spark. The importance of this defect should not be exaggerated, because excellent results can be obtained with an interrupter in which the mercury is almost entirely emulsified in this manner.

In giving a concrete form to the description, the only trouble is the choice. All builders produce interrupters of the mercury type, and nearly all of these various models are capable of giving satisfactory operation. Fig. 80 shows a model in which the electric motor through a crank and a connecting rod operates a plunger guided vertically; the plunging contact is fastened to the connecting rod. The connections between the plunging contact and one of the terminals is made by a flexible copper strip. A fixed

conductor immersed in the lower part of the mercury establishes a connection with the other terminal. A tachometer connected to the opposite end of the motor shaft indicates at each instant the number of interruptions per second.

In certain other models, and particularly in those of Gaiffe, Carpentier, and others, the flexible strip for the

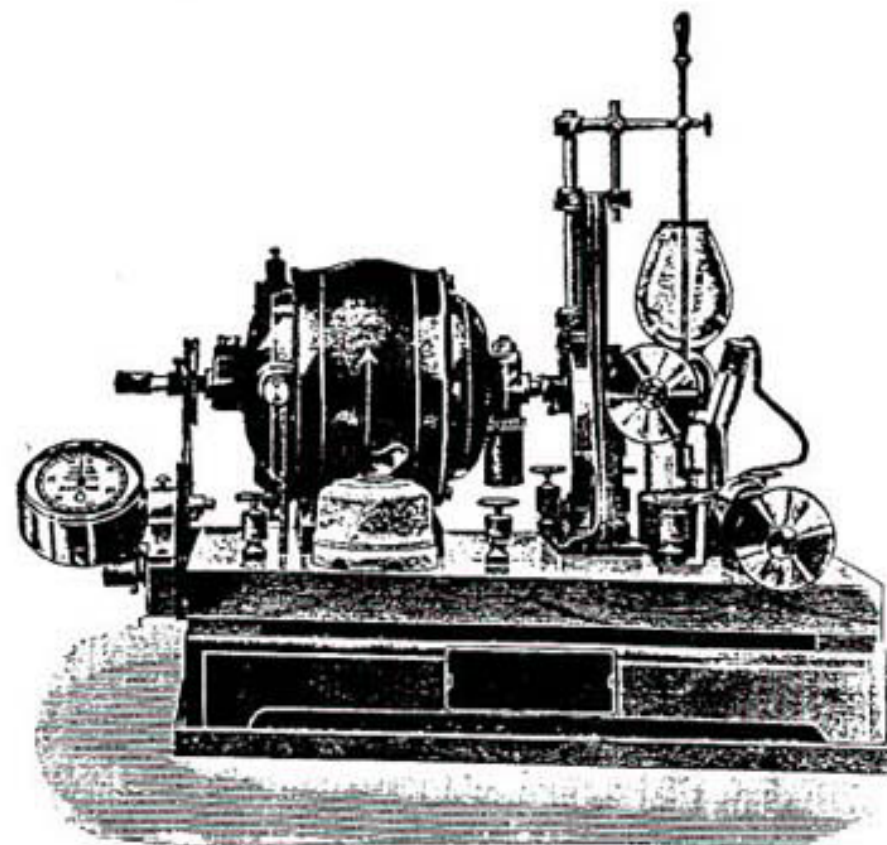

FIG. 80.

connection to the movable plunger is done away with. There are two movable plunging contacts connected together; one is continuously immersed in an auxiliary cup completely filled with mercury, and another in a cup where the rupture is made.

For very rapid interruptions, other arrangements have been proposed; they consist in the use of a turbine which

pumps the mercury to a reservoir and projects it as a rigid column against metallic pieces arranged for this purpose.

The first of this form of apparatus was that of the Allgemeine Electricitäts Gesellschaft (Fig. 81). In this apparatus a small vertical turbine pumps the mercury contained in the reservoir. The mercury mounts in the hollow axle of the turbine up to a horizontal disk where it meets a nozzle from which it is projected by centrifugal force in the form of a fine jet. This jet of mercury while turning, encounters the teeth of a ring suspended in the basin and insulated from it. When the jet falls upon a

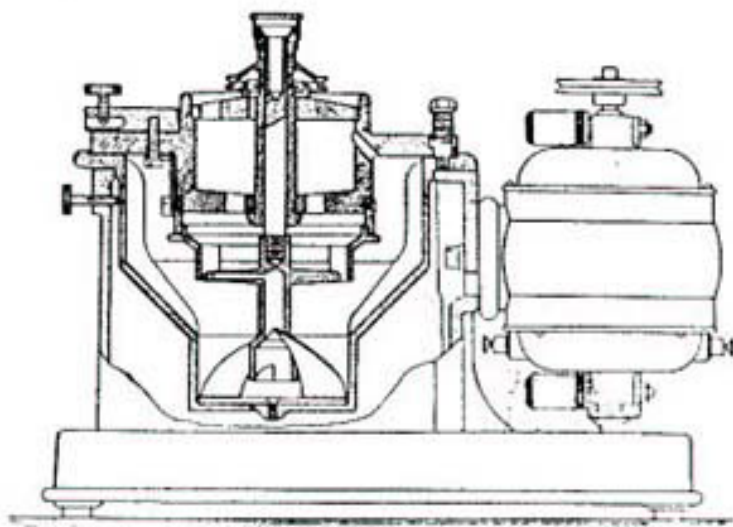

FIG. 81.

tooth, the circuit is closed; it is opened when it passes between two consecutive teeth. The interruptions are very sharply defined, as is also the making of the circuit. The turbine is driven by a small electric motor, which is seen at the side; or, more rarely, by a crank turned by hand. It should be noted that this interrupter does not operate at low frequency. The turbine will not pump the mercury below a certain speed. The interruptions are made in the middle of an insulating liquid, preferably alcohol. The pulverization of the mercury is quite considerable in this apparatus, but there is little inconvenience thereby, since

the turbine pumps only the homogeneous mercury from the bottom of the tank. Two fixed helical vanes prevent the mercury from taking up the rotating movement of the axis, and thus causing the turbine to lose its prime.

With this type of interrupter an accidental or willful stopping of the turbine immediately breaks the circuit; therefore a reostat for preventing an abnormal current in case of stopping is not needed. The frequency of the

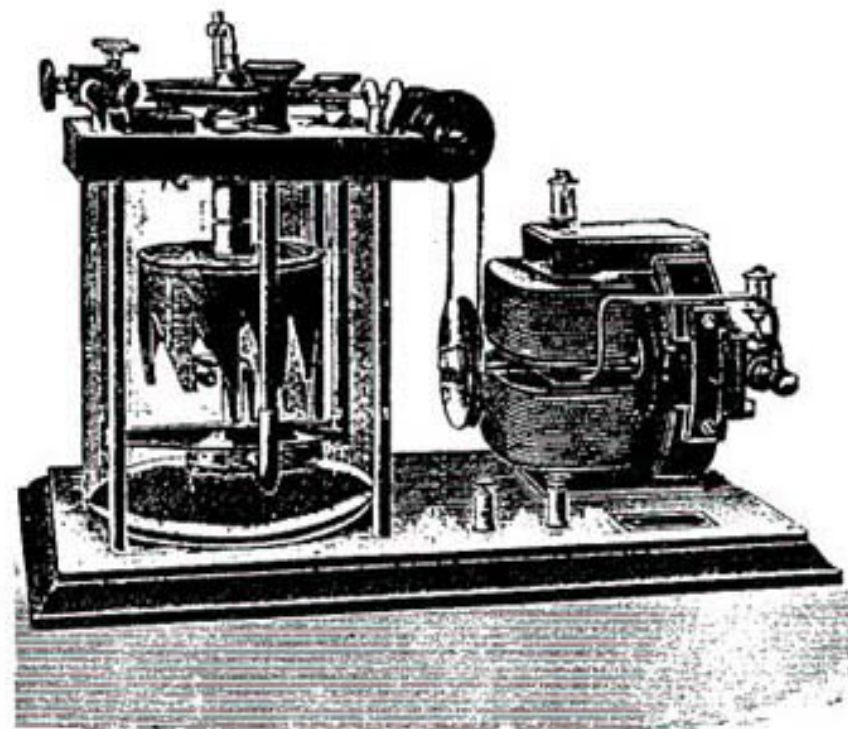

FIG. 82.

interruptions is varied by changing the number of teeth in the middle ring; 150 interruptions per second are easily obtained; above that, the interval between the teeth becomes too small and the current is not always interrupted.

Another form of the turbine interrupter is that of Max Levy in Berlin. In this model (Fig. 82) the jet of mercury is stationary, and the toothed ring turns. The axis of the turbine carries a metallic ring provided with triangular teeth. The mercury pumped by the turbine into the

nozzle and is projected against the teeth, which pass across its path. The nozzle is movable, and may be raised or lowered with the aid of a handle, and in this manner the duration of the contact can be adjusted while the interrupter is in operation, independent of the frequency of the interruptions.

Another class of interrupters in which mercury plays

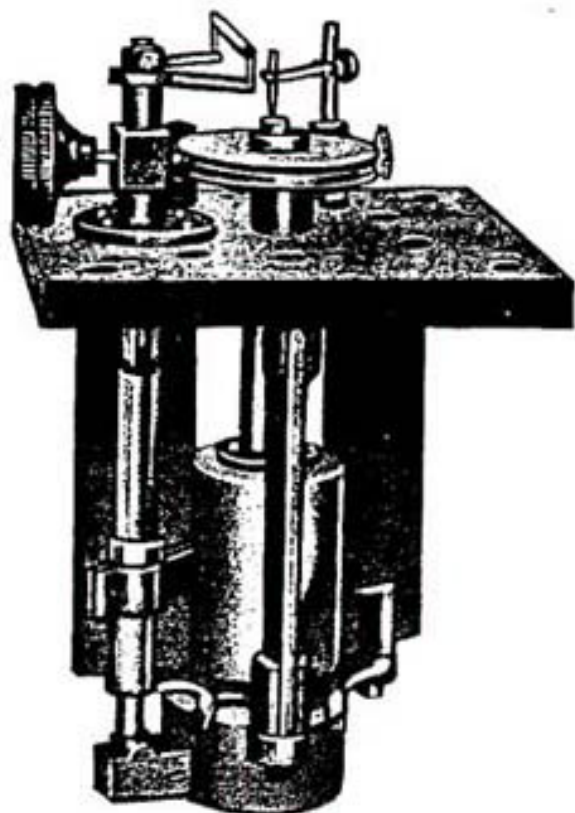

FIG. 83.

an auxiliary rôle may be mentioned here, namely: The interrupters with sliding amalgamated contact. The first of this type appears to have been constructed by Hirschmann in Berlin. The interrupter represented in Fig. 83 is a little different as to construction but it rests on the same principle. A stability drum fastened to a vertical axle turned by a pulley, has part of its surface covered by two strips of amalgamated copper; the strips

are connected in the form of a triangle. Against this drum rests a copper brush, which is provided with a hole along its axis. The brush can be moved along the drum in such a manner as to come in contact with the larger or smaller portion of the copper strips, which in this manner permits the variation of the duration of contact. The vertical axle terminates at the lower end with a small turbine which pumps mercury into the wood cylinder which carries the brush; the circuit for the mercury is from the mercury basin through the turbine, the wooden cylinder and the brush. During rotation, the mercury passes through the brush onto the strip which it amalgamates, and at the same time it assures the electric contact and reduces the sliding friction. A spring adjustable from the exterior regulates the pressure between the brush and the drum. The electric circuit is made from the basin of mercury which encloses the entire interrupter through the mercury to the brush and from there to the axle of the drum when the brush is in contact with the metallic surfaces. The other terminal of the circuit is connected to the axle of the drum. This connection to assure good contact is made by providing the axle at the upper extremity with a small cup filled with mercury, in which a copper wire connected to the terminal is immersed.

In all mercury interrupters the rupture is made in an insulating liquid. There are many dielectrics which may be used for this purpose, and, without doubt, it is best in each case to use the dielectric recommended by the builder of the interrupter.

For a long time alcohol was employed, as recommended by Foucault; naphtha oil has been employed since its introduction by Henry. Pure water has also been recommended. In a general way, water gives very good results with low voltages up to about 20 volts; above that recourse must be had to non-polarizable dielectrics, such as alcohol, petroleum and mineral oils. All hydrocarbons are decomposed by the spark at rupture and leave a powder deposit, probably of carbon, which envelopes the globules

of mercury and prevents them from coming together; it is to this that the gradually increasing division of the mercury is due. To this should be added the effect of the surface tension of the layer of dielectric which envelopes each globule. When the mercury is transformed into this condition after continued use of the interrupter, it must be replaced by new mercury. A large part of the mercury can be recovered by washing it with water if the liquid used was water, or alcohol, with benzine if it was petroleum or mineral oil. By heating the washed mercury agglomeration of the mercury is facilitated.

35. **Diverse interrupters.**—Innumerable varieties of interrupters have been invented. The greater part of them have served no useful purpose; nevertheless, the ingeniousness or the novelty of the system deserve mention, if only to put on guard those who reinvent the same things and are tempted to believe that they are new.

In 1855, Poggendorff pointed out that by producing an interruption in a vacuum, the condenser could be done away with and a very clean rupture be obtained.

The idea was taken up later by M. F. Moore and the apparatus shown in Fig. 84 constructed; this is simply a Neef interrupter placed in a tube from which the air is exhausted. This apparatus has not been used; the corrosion of the contacts is very rapid and is difficult to remedy.

Among the interrupters of the plunging-contact type that of M. Margot, (1897) which may be constructed in a laboratory if needed, should be mentioned. It consists of a helix of heavy copper wire, one of the extremities of which is turned in the direction of the axis of the helix, the other extremity being fastened. If the whole is placed in a crucible containing enough mercury to cover the free end of the helix, the total current will traverse it. The electrodynamic action will draw the turns together and pull the end away from the mercury, producing an interruption in the current.

In order to obtain very high frequency interruptions, Grimsehl (1900) mounts the platinum point, which

plunges into the mercury, on a reed which is made to vibrate by a current of water; the surface of the mercury is constantly cleaned by the current of water. Also for obtaining a high frequency, Arons (1899) proposed carrying the platinum contact at the middle of a vibrating wire attracted by a horseshoe magnet; the system should permit the attainment from 800 to 1000 interruptions per second.

In his researches of 1837, Page used a copper star, the points of which dipped in mercury. The idea was taken up again in 1897 by Hofmeister, and in 1900 by Ducretet. This method is excellent for a short time, at the end of



FIG. 84.

which the pulverization of the mercury is so rapid that it is impossible to make practical use of it.

The interruption of the current by the separation of two layers of mercury has been tried: M. J. Luhne (1900) takes a hollow insulating cylinder cut along a generatrix. This cylinder turns on a horizontal axis, it is nearly full of mercury, and is partly immersed in mercury in a basin; at each revolution the mercury at the interior comes in contact with that at the exterior through the slit in the cylinder, then the circuit is broken by the edge of the slit. Caldwell (1900) employs, for the same purpose, an insulating disk pierced with holes. This disk turns on a

vertical axis and is immersed in a bath of mercury. A glass tube filled with mercury is supported on the disk in such a manner that at each passage of a hole before it, the two layers of mercury are brought into communication.

Bary (1901) produces a fine thread of mercury by means of a capillary tube, the rupture of the current being produced by the action of electrodynamic repulsion between the elements of the current itself.

Villard (1904) passes a jet of mercury between the poles of a permanent magnet; when the value of the current is sufficiently large, the action of the magnet on the conductor is sufficient to break the jet of mercury, which thus interrupts the current. The frequency of the interruptions varies with the voltage and with the current value; it may be regulated by adjusting the length of the free jet. This interrupter, which appears to be very interesting, is too new to be able to judge of its practical value.

Working along another line, Barker (1899) places an arc lamp in a 500-volt circuit in series with a rheostat of 50 ohms resistance, and interrupts the circuit periodically by placing the magnet close to the arc.

36. Electrolytic interrupters.—The rapid success attained by the Wehnelt interrupter was evidently due to its great simplicity, which permitted its easy construction in laboratories. The description should commence with the first model, which is always useful in case of necessity where other appliances are not at hand.

In its most simple form (Fig. 42), the Wehnelt interrupter is composed of a platinum wire, a few tenths of a millimeter in diameter, soldered to the extremity of a glass tube; the latter is filled with mercury in which a copper wire is immersed to make connection with the positive pole of the battery. The glass tube is immersed in a jar filled with acidulated water, or some other electrolyte. A sheet of lead connected to the negative pole forms the cathode of the system. The surface of the platinum which is in contact with the electrolyte, must

be proportioned to the value of current which it is desired to obtain, and also to the coefficient of self-induction of the circuit, and to the e.m.f. of the source. The heating of the platinum wire often causes the glass tube to break. It is often more advantageous to solder the platinum wire to the heavy copper wire, and to place the two in a tube of glass almost closed at the bottom, having a hole just



FIG. 85.

sufficient to allow the platinum wire to pass. In order to avoid the corrosion of the copper, it is well to varnish it heavily. With this arrangement the length of platinum in contact with the electrolyte is easily regulated.

The interrupters now on the market differ from this simple model only by their more robust and appropriate construction. In the models of Siemens & Halske and Max Levy (Fig. 85), the platinum wire emerges from a

porcelain tube placed in the center of a jar containing the electrolyte. A movable thumb-nut is used to adjust the length of platinum in contact with the electrolyte. The cathode is a sheet of lead carried on the side at the base; it is sometimes rolled on the porcelain tube so that the two electrodes are fastened to the cover, the jar serving simply to hold the electrolyte; an arrangement analogous to the last was employed in 1898 by E. Thomson and R. Shand. In order to prevent corrosion of the metallic pieces, there is provided at the top of the porcelain tube

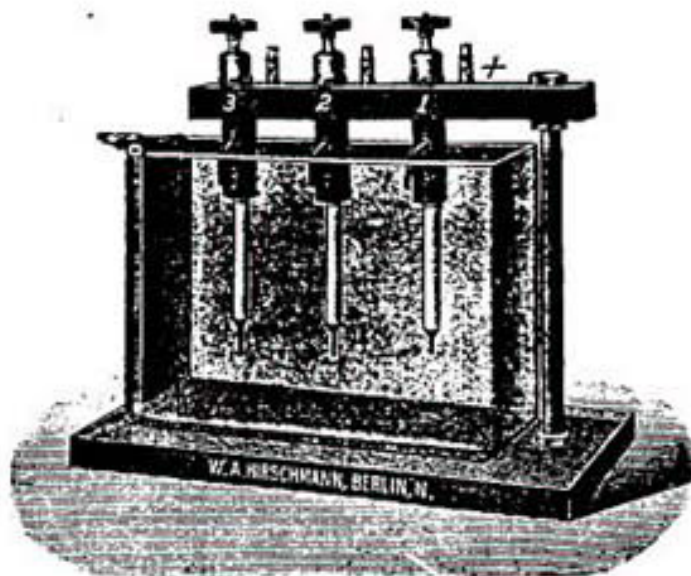

FIG. 86.

an overflow by which the liquid which mounts in the tube can escape.

The adjustment of the anode by moving the platinum wire in and out of the electrolyte requires the presence of the operator near the interrupter. This condition is sometimes difficult to satisfy; for example, in radiography it may be necessary to spare the patient the noise of the interrupter. In this case instruments using several anodes of different surfaces are employed (Fig. 86), the terminals being connected to a switchboard placed near to the

operator. The simple movement of a switch suffices to place in the circuit the anode, the surface of which is suited to the result to be obtained.

We have seen the inconvenience caused by the heating of the electrolyte; in order to avoid this, a cooling coil is often immersed in electrolyte and traversed by cold water (Fig. 87); in this way the temperature rise is controlled. This arrangement, which is useful for prolonged operation, may advantageously be replaced by a jar of large

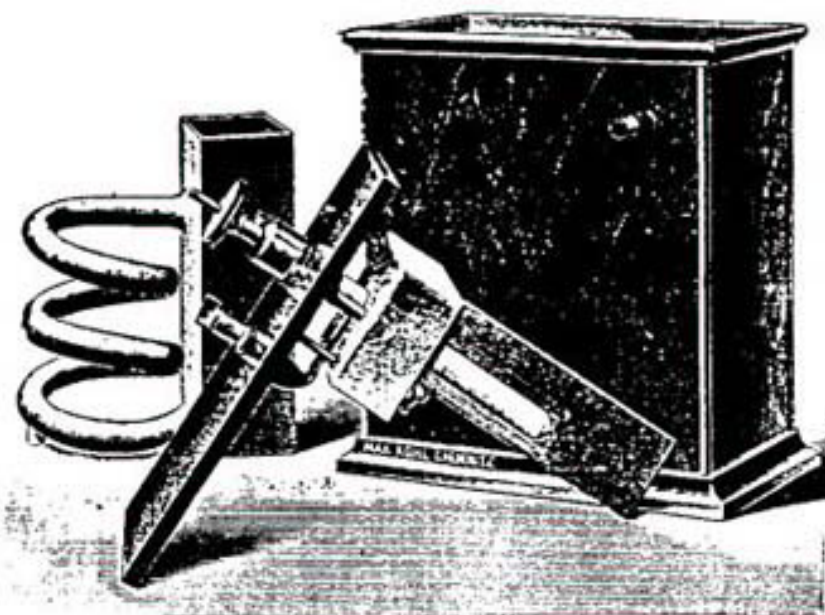

FIG. 87.

dimensions when the duration of operation does not exceed an hour.

The system of Jirotko Levy is intended particularly for continuous operation; it consists of conducting about the anode a current of air which cools it, drives away the steam bubbles and regulates the action. The anode is fixed at the curved extremity of a glass tube, the opening in which is large enough to allow the passage of the current of air sent into the tube by a small electric fan. This system appears to produce a saving in electrical energy.

If, on the contrary, it is desired to operate at low voltage (12 to 30 volts), it is advantageous to employ a warm electrolyte. The model by Carpentier (Fig. 88) is designed for this purpose; it is composed of an adjustable anode mounted in a glass tube and placed in a lead cell forming the cathode. The cell is covered with felt and incased in a wooden box, so as to prevent cooling. The electrolyte is heated to 55° or 95° cent. before filling, or is heated in the

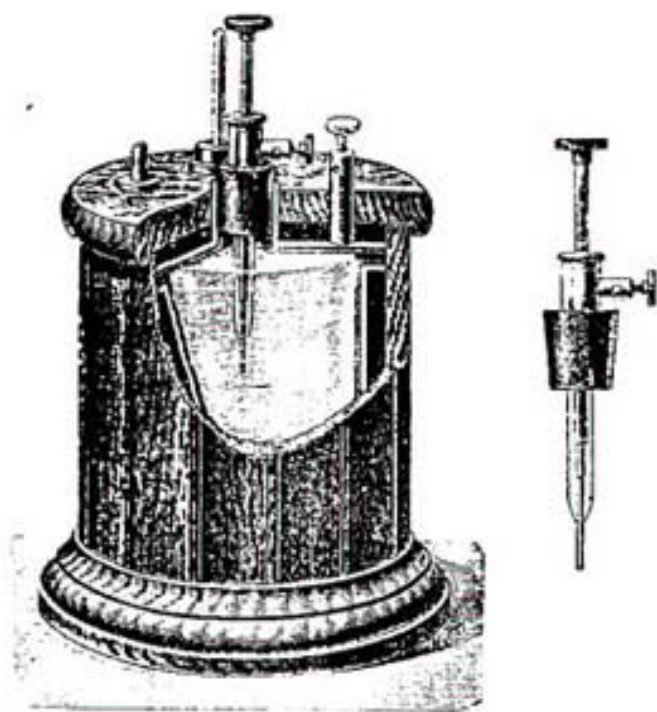

FIG. 88.

cell by operating the interrupter at high voltage. This interrupter will operate at very low voltage and hot sparks of relatively low frequency analogous to those of the mercury interrupter can be obtained. Operation at low voltage and high frequency may be obtained according to Rzewerski, by directing a current of diluted acid against the anode, so as to avoid the formation of gas bubbles. By this means that author is said to have obtained 450 interruptions per second with 24 volts.

Among the various forms of Wehnelt interrupters, that of J. V. Pallich may be cited. The anode is formed by a steel wire from one to two millimeters in diameter, and the cathode with a copper wire of from 3 to 4 millimeters in diameter, the two electrodes being enveloped in glass tubes almost to the end. The steel wire is used up very rapidly, but it is necessary simply to move it forward in its tube.

The arrangement of Gaiffe-Gallot is intended to remedy



FIG. 89.

the ill effects caused by the wear of the platinum anode which is always produced when operating with alternating current. For this purpose the platinum wire passes freely in the insulating sheath and rests against an insulating support, so that its length is determined by the distance between the support and the end of the sheathing; this distance may be adjusted at will by moving the sheath up or down. When under the action of the current the plati-

num wire becomes worn, it descends by its own weight, so as to always rest against the support.

Interrupters of the type Simon-Caldwell, as we have seen, have the advantage of being symmetrical; therefore they lend themselves readily to use with alternating current, and give equal intensities for both half-waves.

In the model shown in Fig. 89 an electrode of lead is immersed in the outside jar; the other electrode is placed in a porcelain tube, the lower extremity of which is pierced with two small holes. All the heating is produced in the narrow part of the electrolytic conductor—that is to say, in the holes. The result of this is a rapid disintegration of

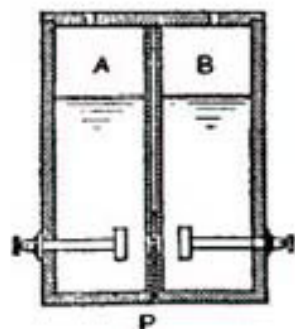

FIG. 90.

the porcelain at this point; the hole increases in diameter, and the tube must be renewed.

Certain builders, in order to overcome this annoyance, use a larger hole in which a conical needle of glass can be inserted, so as to regulate the size of the opening.

A very important fact which should always be taken into account, is that the liquid rises continually in the cell of small diameter; it is, therefore, indispensable to provide an overflow which will return the electrolyte to the outside.

An interesting model was brought out by Ruhmer in Berlin, which consists of two small cylindrical cells, *A* and *B* (Fig. 90); the two flat walls are pierced by a hole which establishes communication between the two cells. A space is left between the two walls in which a porcelain plate, *P*,

also pierced with a hole corresponding to those in the walls, can be placed. In this way the diameter of the hole can easily be varied by changing the porcelain plate; also, it can be replaced when the size of the hole has become enlarged through continued operation.

The liquids which may be employed in electrolytic interrupters are numerous. The most common, and the one which gives the best results, is sulphuric acid diluted from 20° to 25° Baumé. This solution has the disadvantage of liberating, during operation, an abundance of very corrosive acid vapors, which limits its use to laboratories which are well ventilated, or, requires that the apparatus be well closed, so that the vapors cannot escape, except by a tube leading to an alkaline solution.

Concentrated solutions of caustic potash, or soda which have also been recommended, do not have this disadvantage, but the results obtained are not as satisfactory as with acid, and also the liquid is very corrosive. Thus to avoid this inconvenience which frequently occurs in medical application the use of a saturated solution of ordinary alum or sulphate of magnesium is recommended.

The fields of application of these different arrangements of interrupters are as follows: For a low voltage, 10 to 30 volts, the Wehnelt with warm electrolyte at a temperature near boiling. From 30 to 120 volts, the Wehnelt with a cold electrolyte maintaining the temperature by artificial cooling if the interrupter should operate continuously. Finally for operation at about 120 volts, the Simon-Caldwell interrupter appears to be preferable; it commences to give good results above 50 volts.

37. **Interrupters for alternating current.**—In order to operate on alternating current, interrupters should be able to synchronize with the frequency of the current employed. Of those interrupters which have no natural period, the atonic interrupters of Carpentier, for example, may be adjusted for this purpose; it suffices to regulate the tension of the spring. In this way it is possible to obtain either one spark each period corresponding to one of the half-

waves, or a spark for each half-wave. This adjustment is very delicate and a little difficult. It can easily happen in the case where there is only one spark per period, that the polarity of the half-waves in which the interruption is produced should change and, therefore, the polarity of the secondary would also change.

Villard has constructed a special interrupter for alternating current (Fig. 91). The tuning-fork which he employs for continuous current is here replaced by a simple vibrating strip fastened at one end and carrying at the other a contact which plunges in mercury; this strip passes

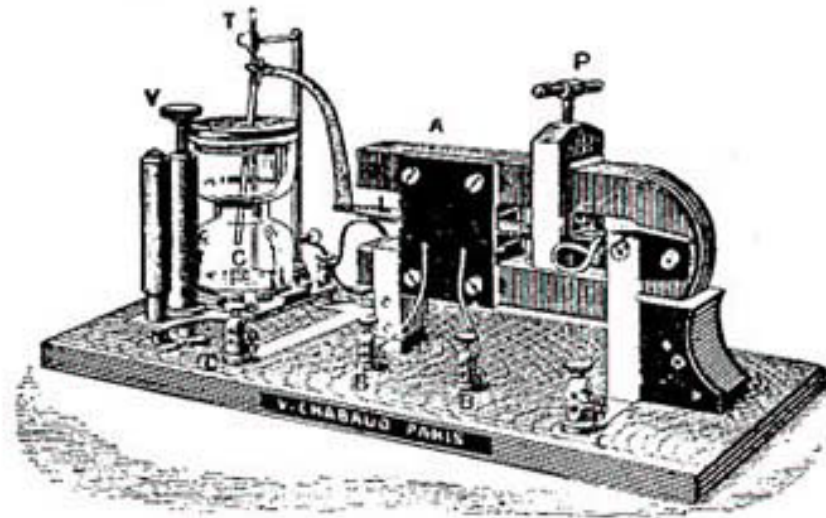

FIG. 91.

before a solenoid fed with alternating current taken from the same source as the current which is to be interrupted. It is, therefore, polarized alternately in one direction, and, then in the other; and, since it is mounted between two poles of a strong permanent magnet, it is attracted first by one pole, and, then by the other; it vibrates synchronously with the alternating current. The solenoid is fed from a small transformer intended to give to the movement of the vibrating strip the necessary retard, so that the rupture of the circuit will always be made at the moment when the current value is a maximum. This

interrupter produces one interruption per period; it acts, therefore, as a current rectifier.

Turbine interrupters can be driven by synchronous motors, so that the interruptions will occur in each half-wave; or, if it is preferred, discharges of the same polarity can be obtained by suppressing half of the teeth on which the mercury jet falls. The A.E.G. have designed a turbine interrupter of this type (Fig. 92); the motor is direct-connected to the

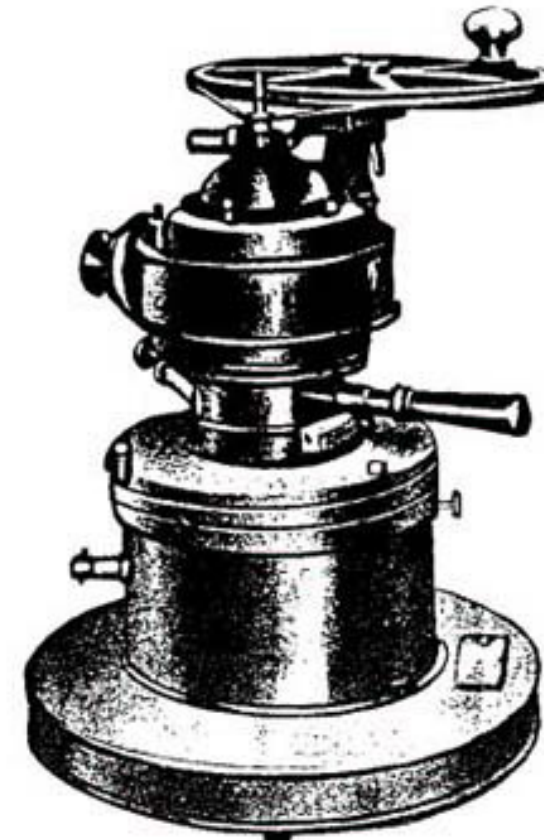

FIG. 92.

shaft of the turbine, and the motor is so mounted that it can be adjusted through a certain angle with reference to the turbine, so as to produce the interruption at the moment of maximum current value. A hand wheel is used to start the motor.

Electrolytic interrupters operate with alternating current

as well as with continuous current, and this is one of the greatest advantages which they possess. However, we have seen that the Wehnelt interrupter gives very different effects, depending on whether the platinum wire is anode or cathode. This property is utilized to obtain discharges which are nearly of a single polarity; in fact, in many cases this result is attained; the half-wave, where the platinum is cathode, being very nearly suppressed; this suppression is, however, not complete enough for radiographic work.

The Simon-Caldwell interrupter being symmetrical, gives equal discharges in each direction; these discharges are alternating and cannot be used directly with cathode tubes.

Since in many places alternating current only is available, the problem of exciting induction coils with this kind of current often presents itself, particularly for medical work. Independently, of interrupters operating directly on alternating current of which we have just spoken, methods have been tried which permit the charging of storage batteries from the street network, so as to obtain a direct current for the induction coils afterward. We will not treat the most rational method, which consists in transforming alternating current to continuous by means of synchronous converters, or by motor-generators; these installations do not come within the scope of this work. However, we will examine some systems which in certain cases may be of service.

Several forms of electromagnetic rectifiers have been proposed, among them that of Koch constructed by Hirschmann. They all rest on the properties of polarized relays. A strip of soft iron polarized by a permanent magnet is submitted to the action of two electromagnets fed with alternating current; each of the electromagnets successively attracts and repels the armature when the current changes inside. By its movement, the armature reverses the connections of the charging circuit to the storage batteries, so that they receive pulsating direct-current. These rectifiers require a very delicate ad-

justment. The phase of the current in the electromagnet must be such that the reversal of connections is made at the moment when the alternating e.m.f. passes through zero, so as to obtain a proper utilization of the energy and to avoid sparks at the contacts. This adjustment is obtained by means of choke coils and condensers. The Villard interrupter and the turbine for alternating current, if they are properly retarded so that the rupture of the circuit will take place at the proper moment, may be used for the same purpose.

Another solution, more simple, is furnished by the electrolytic valves, the practical success of which is due to Pollak. In an electrolyte in which a sheet of lead and a sheet of aluminum are immersed, the electricity will pass easily in the direction from lead to aluminum, while a

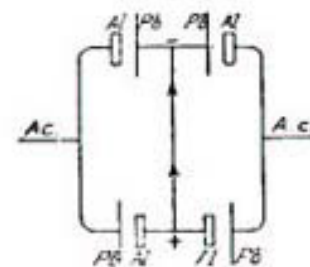

FIG. 93.

very considerable e.m.f. will be necessary to pass it from aluminum to the lead; in other words, the aluminum anode opposes to the passage of electricity an infinite resistance as long as the e.m.f. is below a value which varies from 20 to 200 volts, according to the nature of the electrolyte.

From this it is seen that a cell containing an arrangement of this form is a veritable valve for alternating current, letting only the electricity from one side pass, stopping that from the other. In practice, in order to obtain better utilization of the energy by employing both half-waves, four similar cells are interconnected, as shown in Fig. 93. It is easily seen that the current can always exist in the circuit, and that the branch in which the re-

ceivers are placed always carries a current in the same direction. Various electrolytes may be employed, but use is frequently made of alkaline phosphates. Practice has not yet sanctioned the use of this apparatus; we can only call attention to them.*

*At the present writing (1908), the electrolytic aluminum rectifier is used extensively for supplying direct current to storage batteries, small motor generators, induction coils, etc. They are built to operate at current values up to 30 or 40 amperes. Rectifiers used in connection with induction coils are often composed of only one aluminum cell. This one-cell form does not rectify the current, but simply suppresses one-half of the current wave producing a pulsating direct-current.

CHAPTER IX.

SPECIAL APPARATUS.

38. **Tesla transformer.**—Together with the induction coils such as have been treated up to this point, mention should be made of certain special apparatus which differs more or less from the induction coil, but which has a point in common with it; namely, the production of separate discharges, each forming a series of damped oscillations.

With the high-frequency apparatus of which Tesla discovered the principle, we enter into a very important field. We will not go very deeply into this subject, and will content ourselves by outlining the principal systems so that their operation may be understood.

The principle upon which the Tesla coil is based, consists in introducing high-frequency currents from the discharge of the condenser into the winding of a special transformer; the condenser being charged by means of an induction coil, or a transformer of low frequency and high tension. The apparatus may be connected in two ways, both pointed out by Tesla in 1891. In the first arrangement, symmetrical connection (Fig. 94)—the circuits, 1 and 2, represent either an induction coil, or a commercial high-voltage transformer. The coil charges two condensers, C and C' , which are connected to the primary, 3, of a high-frequency transformer. A spark-gap, AB , is connected to the terminals of circuit 2, and the balls, A and B , are brought close enough together so that numerous sparks may form, but precautions are taken to prevent them from forming an arc.

What takes place may be explained by supposing the transformer, 1, 2 is an ordinary induction coil. Fig. 95

gives a rough idea of the phenomena. During the establishment of the primary current, I_1 , a small value of sec-

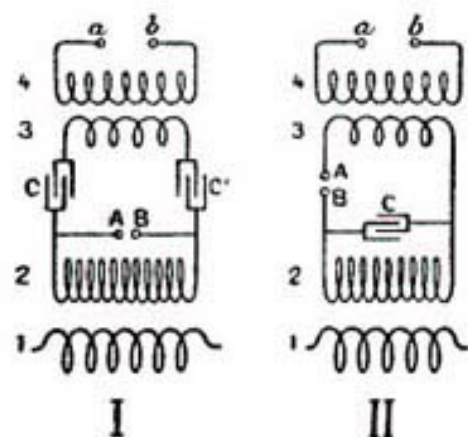

FIG. 94.

I. Symmetrical Connection. II. Connection with One Condenser.

ondary current is produced; but as we have seen, the e.m.f. is not sufficient to produce a spark between A and B . At the moment of rupture, the current, i_2 , takes the

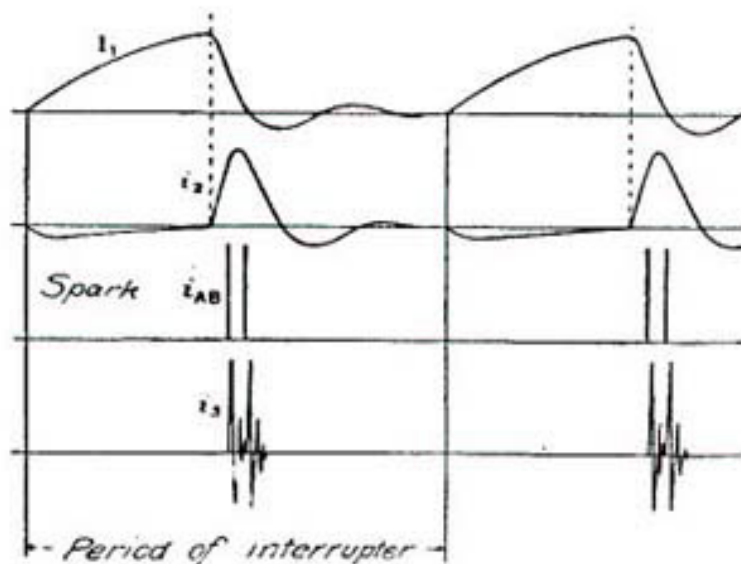

FIG. 95.

well known form: oscillations of the order of a hundred or thousand per second, rapidly damped, are produced

in the circuit charging the condensers, C and C' , and circulating at the same time in circuit 3, which is connected to C and C' . When the condensers are charged to a sufficient potential, a spark is formed between A and B which produces a sudden variation in the charge of the condensers.

At this moment very rapid oscillations are produced in circuit 3; they have a period which is determined by the capacity of the condensers, C and C' , and by the coefficient of self-induction of circuit 3. These oscillations are damped; they may be completely wiped out at the moment when the following spark is produced between A and B . At each rupture of the current, I_1 , there may be a greater or less number of sparks at $A B$, each of them giving birth to a group of analogous oscillations, and the current in 3 has a form similar to that of i_2 .

The current, i_2 , evidently has not the regular form indicated here; as each spark at $A B$ of the primary-current curve should contain a dip analogous to those shown in the oscillogram (Fig. 31). The value of the instantaneous currents, i_{AB} , which exist with each spark should be considerable in comparison with the value of i_2 ; in fact, the sparks in $A B$ have an extremely short duration. They may be oscillating, but their period is infinitely shorter than that of the oscillations of i_2 , because of the coefficient of self-induction of the discharge circuit is much smaller than that of circuit 3. It is not an exaggeration to say, because experience proves it, that the instantaneous value of current in the spark may in certain cases attain several hundred amperes when the maximum of i_2 is not one ampere. The difference between the instantaneous values is caused simply by the difference in the duration of the phenomena.

The high-frequency current produced in circuit 3 is more exactly a current of very short period, because it is easy to see that the duration of the useful phenomena (that of circuit 3) is a very small fraction of the total time. The necessity of demonstrating the phases of the phenomena forced a considerable alteration of Fig. 95;

we will try to re-establish more true proportions. Suppose that the interrupter employed has a frequency of 50 per second, that is, a period of 0.02 second; an ordinary coil with a capacity, such as usually employed for the Tesla currents, gives a secondary period of oscillation of the order of 0.005 seconds (about 0.01 to 0.001 second). The sparks at AB are produced only during the first half oscillation of i_2 , then it is necessary that the potential be greater than a certain value; the useful phenomena lasts, therefore, during a shorter time than this half oscillation. We can say without exaggeration that the duration is very much less than 0.001 of a second—in this case much less than $\frac{1}{20}$ of the total time. The mean lengths and the

capacity of circuit 3 being given, the oscillations which can be produced are probably of the order of a millionth of a second. We have no idea of the magnitude of the damping in this circuit; according to calculation, it would be very little; but it is probable that there are other causes of loss of energy than the Joulean effect, the electric radiation for example.

The e.m.f. generated in the secondary circuit of the Tesla coil (circuit 4) has the same form as i_3 , but lags one-fourth of a period behind this current.

The second arrangement indicated by Tesla (Fig. 94) is provided with only one condenser, and the spark-gap is in series with the coil, 3. The operation of this arrangement is very much the same as that of the first. The two methods give results which differ very little, but the first, from the point of view of security, has the advantage that one may touch circuit 3 without danger. In case an arc forms between A and B , coil 3 may be carried to a dangerous voltage; in the case of the second arrangement, while under the same conditions, it is insulated from the low-frequency high-tension circuit when the first system is employed.

The Tesla transformer consists essentially of a primary circuit formed by several turns of heavy wire; the diam-

eter of these turns may lie between 5 cm. and 20 cm. The secondary is made up of a larger number of turns of wire, a little smaller in diameter. The ratio between the number of turns varies according to the service; it may vary from 2 to 20; the latter figure is seldom exceeded. The two circuits should be well insulated from each other and made up of large wires covered with a thick layer of insulation. The insulation between the two circuits often consists of a glass tube. The whole is generally immersed in oil so as to increase the insulation and to avoid energy losses by radiation.

It may seem astonishing at first that such a small coefficient of transformation will permit the production of such high e.m.fs. in the secondary; it is known that with a spark between AB , which is but a few millimeters long, a spark between a and b can be easily obtained which is from 20 cm. to 25 cm. long, using a coefficient of transformation of only 3 or 4. This phenomena is easily explained: With each spark at AB , oscillations are produced in circuit 3 and a very high e.m.f. of self-induction is produced in the circuit; the condensers, C, C' , are charged and their e.m.f. is, at each instant, equal and opposed of the e.m.f. of circuit 3. We have—neglecting the damping of the oscillations and calling E , the difference of potential between A and B ; e the difference of potential across the condenser; e_s the e.m.f. of self-induction, and R the resistance of the circuit:

$$\omega^2 C L = 1, \quad i_{AB} = \frac{E}{R} \sin \omega t.$$

$$e = \frac{1}{\omega C R} E \sin \left(\omega t - \frac{\pi}{2} \right).$$

$$e_s = \frac{\omega L}{R} E \sin \left(\omega t + \frac{\pi}{2} \right).$$

It is easy to see that the smaller R , the greater the ratio of e and e_s to E . In the high-frequency transformers, the e.m.f. which is multiplied by the coefficient of transforma-

tion is that which is produced in circuit 3, it is e_s , and not the difference of potential, E , applied to the terminals of the condensers, C, C' ; the magnitude of E simply determines the length of the spark at $A B$, and there may exist between the terminals of circuit 3 a difference of potential very much greater. For instance, an induction coil could be placed in shunt with circuit 3 and obtain between a and b (Fig. 96) sparks several centimeters long. d'Arsonval uses this arrangement: he suppresses the secondary of the Tesla coil, and utilizes only the difference of potential which exists between the terminals of a coil of large wire, which is made up of a few turns and forms the circuit, S . The results obtained under these conditions are absolutely the same as those which are obtained with

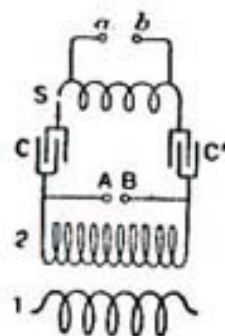

FIG. 96.

the Tesla coil; they differ only in value of the e.m.f., which is naturally very little.

Where the arrangement of Tesla or d'Arsonval is employed, one essential condition must be fulfilled; namely, the sparks at $A B$ must be white and crackling; above all things, the formation of an arc must be prevented. This condition requires special provisions, because with a short gap generally employed between A and B , the air becomes heated very rapidly, and the high tension of circuit 2 tends to establish an arc.

One of the means employed at the beginning by Tesla, consisted in extinguishing the spark by the aid of a strong current of air directed between the balls, A, B . The

second means consisted in utilizing the action of a magnetic field on the current—that is, the magnetic blowout. The balls, A, B , are placed between the poles of a strong electromagnet, the lines of force being perpendicular to the direction of the sparks; the poles of the magnet must be protected from the discharges by means of heavy plates of mica. The magnetic blowout is more affective than the air; the latter has been much simplified by d'Arsonval, who instead of blowing the air between stationary balls, moves the spark through the air. In the d'Arsonval system, the balls, A, B , or the rods which replace them, are mounted on a small electric motor which causes them to describe a circle from 10 cm. to 20 cm. in diameter; the sparks form in this manner at different points, and the duration of a revolution is sufficient to allow the air heated by a spark, to regain the temperature of the surrounding air, before a new spark is formed at the same point.

Another arrangement brought forward by Messrs. d'Arsonval and Gaiffe, consists in connecting between the terminals of circuit 2 (Fig. 96) an auxiliary condenser and connecting the same terminals to the spark-gap, $A B$, by means of two resistances.

In order to prevent the formation of an arc, it is important that the balls of a gap be as highly polished as possible; each spark corrodes the surface where it forms, and the roughness thus produced facilitates the passages of discharges and leads the disruptive e.m.f. rapidly to the formation of an arc.

In the majority of high-frequency systems, the length of circuit 4 is about the same as the length of the wave of the oscillations developed in circuit 3; if by proper adjustment of the capacities, C and C' , a length of wave is obtained which is equal to four times the length of circuit 4, stationary waves will be developed in the latter (Fig. 97, A); if one of the extremities is connected to the earth, its potential, E , is zero, but it carries a maximum value of current; on the other hand, at the free end of the circuit, the values

of the current is zero, but the potential is a maximum. When resonance does not exist between circuits 3 and 4, the difference of potential obtained between the balls, *a* and *b*, is less; therefore, it is advantageous to tune the two

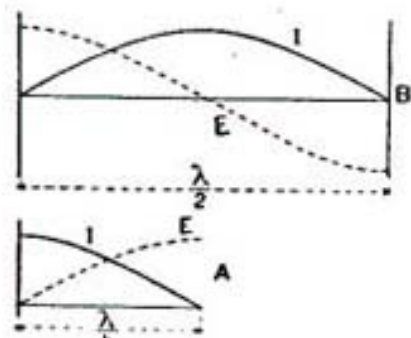

FIG. 97.

circuits in order to obtain the greatest effect with the least amount of energy (B. No. 48).

39. **Resonators.**—An apparatus introduced by Tesla is employed to a great extent to-day by medical men and is known as the resonator. Although the effects produced are quite complicated, they can be reduced to Tesla transform-

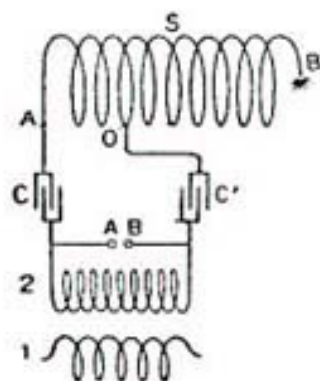

FIG. 98.

ers, in which the circuits are simply insulated in air, and in which the tuning between the primary and the secondary circuit is exactly adjusted.

The first resonator built, that of Dr. Oudin (Fig. 98), consisted of a large coil, *S*, formed of from 50 to 100 turns

of heavy bars of copper wire, wound on a wooden core, and separated from each other by a few millimeters of air. One of the extremities, *A*, of the coil is connected invariably to a condenser, *C*, while the second condenser, *C'*, is connected to a sliding contact, *O*, which may be adjusted along the turns of the resonator. It is easily seen that by proper adjustment of the point, *O*, the coefficient of self-induction of circuit *AO* can be regulated in such a manner that the oscillations there developed will have a length equal to four times the length of the circuit between *O* and *B*. The inductive action produced between the turns in *AO* and those in *OB*, determines the production of stationary waves; the potential at *B* is a maximum, brush discharge being produced at this point, and if it is approached by a conductor, sparks several centimeters long will be formed. If the point, *O*, is connected to the earth, the law of distribution of potential and current represented by Fig. 97, *A*, will approximately obtain; but if any point in the circuit is touched, equilibrium is destroyed. In this apparatus the effect obtained is the resultant of two actions; namely, the induction of the turns of the part, *AO*, on those of the part, *OB*; and the oscillation produced in the part, *OB*, by the variation of the current at point *O*. If the part, *AO*, were placed so that the mutual induction between *AO* and *OB* was zero, the phenomena would still exist, but it would be considerably reduced; in such a manner it would be possible, the tuning being established to cut the coil at the point, *O*, without interrupting the operation of the apparatus.

In order to permit the best possible utilization of the considerable current value which exists at the node of the potential in the resonator, without changing the adjustment of resonance, Captain Ferrié introduced a symmetrical apparatus in which the resonant circuit has a length equal to a half-wave. In this system, which resembles exactly that of Tesla, the inductor circuit, *D*, (Fig. 99) is formed by a single turn of the same size as the secondary turns of the coil, *S*, but completely insulated from them.

The coil, S , is cut in two equal parts, and the connection between two parts is obtained by the aid of a body which is to be submitted to the action of high-frequency currents; the blocks, $P P'$, or appropriate conductors, serve for this connection. In order to adjust primary oscillations to exactly double the length of the wire of the coil, the capacity of the condensers, C and C' , is adjusted. The distribution of potential in the two halves of the coil is symmetrical (Fig. 97, B), the conductors, P, P' , are at a zero potential in such a manner that the electrified body cannot be insulated from earth. It can be touched without causing the least disagreeable feeling, which is contrary to that

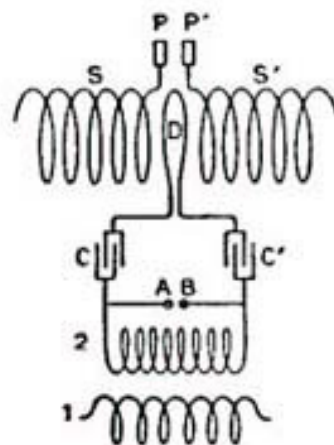

FIG. 99.

which takes place in systems where the electrified body is carried to some potential; in fact, the current value is a maximum at the points, P, P' , where it is necessary to produce the useful effect. In this system resonance is regulated so as to remain always under the most favorable conditions, but in order to vary the value of the current according to the needs, the primary turn, D , can be displaced so as to vary the coefficient of mutual induction between D and $S S'$.

The loss of energy in resonators is considerable, because the oscillations developed in air circuits, presenting a large surface, produce about themselves an intense radiation

of energy. This Tesla tried to avoid by immersing the transformers in oil.

40. **Diverse systems.**—In ordinary induction coils, energy is stored in the primary, and part of it recovered when the rupture of the circuit takes place. It is possible also to store energy in a static form by charging a condenser to a sufficiently high potential, and discharging it in the primary circuit of the coil. This arrangement appears to have been employed for the first time by Norton & Lawrence (B. No. 31); their method consisted in charging a condenser of large capacity, C (Fig. 100-1), on a circuit of e.m.f., E ,

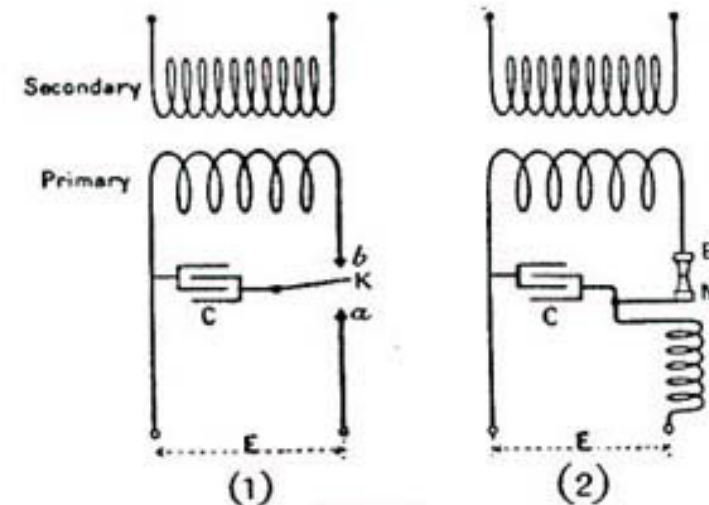

FIG. 100.

and discharging it afterward into the primary circuit of an induction coil by means of a commutator K , driven by an electric motor.

Sometime afterward, Tesla (B. No. 36) proposed an analogous system in which the revolving commutator was replaced by an automatic apparatus composed of an electromagnet, S (Fig. 100-2), excited by the discharging current of the condenser. During the charge the electromagnet, S , attracts its armature, M , but as soon as the condenser is charged, the current ceases in S and the armature, M falls back and discharges C into the primary of the coil.

Assume a condenser of capacity, C , charged by the

e.m.f., E , the quantity of electricity which it contains is CE ; if the resistance of the primary circuit is R , the value of the current, I_t , at the time of the discharge, is measured,

$$I_t = \frac{2CE}{\beta} e^{-\frac{R}{2L}t} \sin \frac{\beta}{2LC} t,$$

$$\beta = \sqrt{4LC - R^2 C^2};$$

We assume here that the resistance of the circuit is small enough to give an oscillatory discharge, as has already been done. We may neglect completely the resistance of the circuit, the value of the current, I_t , then becomes,

$$I_t = E \sqrt{\frac{C}{L}} \sin \frac{1}{\sqrt{CL}} t.$$

The discharge produces in the secondary circuit an e.m.f.,

$$M \frac{dI}{dt} = \frac{M}{L} E \cos \frac{1}{\sqrt{CL}} t,$$

the maximum of which is produced at the beginning of a discharge at the time, $t = 0$; its value is,

$$e_{\max} = \frac{M}{L} E.$$

that is to say, the e.m.f. produced is proportional to the charge voltage of the condenser, multiplied by the coefficient of transformation of the coil. It is, therefore, important to increase this coefficient, if for a constant primary voltage, it is desired to increase the sparks. Although the capacity does not enter into the equation of the e.m.f., it is necessary to take it into account practically, because if it is too small, the energy stored will disappear entirely

in losses—joulean effect, hysteresis, brush discharges, etc.

When dealing with condensers of sufficiently large capacity, it is preferable to charge them in parallel, and discharge them in series; if, for example, there are m condensers of capacity C' , the maximum e.m.f. produced will be equal to,

$$e'_{\max} = m \frac{M}{L} E.$$

The necessity of employing condensers of large capacity, which retain the charge and are capable of resisting high voltage, is the reason why this method is so little used; the advantages which may be obtained with it are more apparent than real; experience shows that energy expended in the two cases is about the same. The only serious advantage which is possessed by this arrangement, is that it permits the use of from 110 to 220 volts and more, without the use of rheostats which cause a great loss of energy.

Finally, we will mention an arrangement by E. Thomson (B. No. 35), which differs slightly from the classical induction coil, but which does not appear to have been used. This arrangement consists in utilizing a current from an ordinary distribution circuit, that is, more than 100 volts, in a primary winding made up of relatively fine wire, and interrupting this circuit with a rotary interrupter. The rupture produces a high value of current in the secondary circuit, which is made up of heavy wire, and this current is in turn ruptured by a rotary contact. By suitably choosing the moment of rupture of the current, there is developed, in a third circuit of very fine wire, a very high e.m.f. It is difficult to judge without experience, the value of this arrangement.

CHAPTER X.

USES OF INDUCTION COILS.

41. Installation and regulation of induction coils.—The source of energy available often determines the choice of the coil, or, at least, of the interrupter; reciprocally, a given coil destined to a given service, determines the choice of source.

When a continuous-current distribution system operating at 110 or 220 volts is available, the largest coils can easily be operated with a liquid interrupter, or an electrolytic interrupter; it is not so easy under these conditions to use a small coil with dry interrupters.

If it is desired to operate a coil employing a low voltage (less than 30 volts for example) from a distribution system, two rheostats, *A* and *B*, may be placed in series between the conductors (Fig. 101) and the coil connected in shunt with one of them. The size of the rheostats, *A* and *B*, may be chosen when the following conditions are given: The coil should operate with an e.m.f., E_1 , less than the e.m.f. of the distribution system; good satisfactory operation of the coil demands that the value of the current at the moment of rupture be at least equal to I_0 . It is easy to see that these conditions will be fulfilled if,

$$R_A = E \left(\frac{1}{I_0} - \frac{K}{E_1} \right).$$

$$R_B = K \frac{E_1}{E - E_1}.$$

The two rheostats should be capable of carrying a maximum current of

$$I_A = I_0 \frac{R_B + R}{R_B},$$

for R_A , and

$$I_B = \frac{E_1}{R_B},$$

for R_B .

Under these conditions the difference in potential, E , varies between E_1 and $E_0 = R I_0$, so that the establishment of the current requires a longer time than in a circuit where the e.m.f. is constant at E_1 . In order to avoid this difficulty, the values of R_A and R_B must be calculated

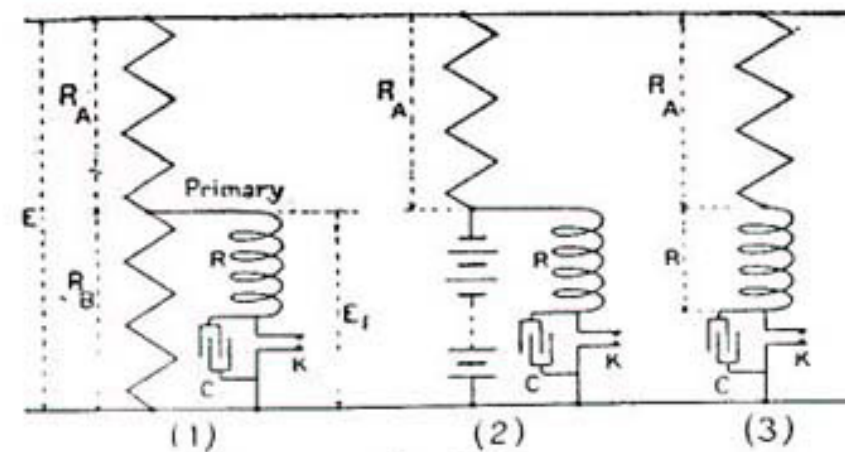

FIG. 101.

beginning with a value slightly greater than the one which it is desired to attain, by taking, for example, I_0 a quarter greater than the necessary value.

This is a costly expedient. It is better, whenever possible, to use storage batteries charged from the distribution system, and which can remain connected to the charging circuit when in use (Fig. 101-2); the expenditure of energy is the same, counting the losses in the batteries, as that obtained when using a single rheostat, R_A , with a mercury interrupter (Fig. 101-3).

When a mercury interrupter is used on a continuous-current distribution circuit, it has been shown that the

value of the current must be limited to a maximum, by means of a rheostat (Fig. 101-3), or a circuit-breaker, so as to prevent the destruction of the coil, in case of stoppage of the interrupter, or too long duration of contact. The use of a circuit-breaker is preferable from the point of view of efficiency, but its operation is not always sure, and one may be obliged to use a rheostat. In this case the resistance of the rheostat must be such as to allow the current to exceed the limit, I_0 , so that this value will be rapidly attained. The more rapid the interrupter, the less the value of resistance connected if it is desired always to interrupt the current at the value, I_0 ; from this it results that for a certain speed the resistance is no longer sufficient to protect the coil in case of stoppage, it is necessary to have recourse to a cut-out, or a fuse. This latter means is still less sure because the value of current at which it melts is very variable, and also the renewal of a fuse requires a longer time than the replacing of a circuit-breaker.

Excepting the regulating rheostat, all parts of the circuit should have as low a resistance as possible; the connecting wires should be of large diameter and well insulated; wire covered with rubber, which is only used for lighting installations, is very good for this purpose; a diameter of 2 millimeters is very satisfactory for ordinary coils which require a mean current of from 5 to 10 amperes, or more.

When a primary condenser separate from the coil is used, care must be taken to connect the condenser to the interrupter with large short wires; avoiding turns and bends this precaution is of capital importance.

The power absorbed by a coil depends on the duration of its operation. A coil capable of carrying a mean current of from 15 to 20 amperes for a few minutes, should generally not be worked at more than 5 amperes continuously, because of the heating of the primary circuit and of the iron core. It should not be forgotten that the majority of coils have small facilities for cooling and that there is great danger of destroying them by heating. The normal conditions

of operation should be given by the builder; or when these instructions are not available, they should be determined experimentally in the following manner: The coil is put into service under certain conditions and at the end of a certain time the resistance of the primary is measured, stopping the coil just long enough to make the measurement. When this resistance has increased 20 per cent., which corresponds to 50° C temperature rise, the experiment must be stopped to await cooling. According to the rapidity of the temperature rise, it is possible to determine whether one is operating the coil near its normal capacity, or not.

The direction of the primary current in the coil is generally of no importance; it is determined entirely by the direction of the secondary current which it is desired to obtain. In order to determine the direction of the latter, a spark-gap formed between a point and a plate as we have seen, or a spark between two wires can be observed. The whitest part is at the negative pole; this last means cannot be employed when the coil furnishes non-condensed sparks of a red or yellowish tint.

With X ray tubes, the direction of the current can be judged from the aspect of the tube itself, but this means has little to recommend it; it is better not to make connections, until one is assured of the direction of the current; in this way deterioration of the tube is avoided.

In a certain number of fields of application, wireless telegraphy, radiography of living bodies, etc., one is obliged to connect one pole to the ground; the question arises as to the limit to which this proceeding may be carried without danger. From what we have seen the insulation between the primary and the secondary is at least capable of resisting a length of sparks equal to one-half the maximum which can be produced by the coil, since it is the normal e.m.f. to which this insulation is submitted; but if one of the secondary terminals is connected to earth, the e.m.f. may become doubled.

If one terminal is to be connected to earth and the maximum length of sparks employed, operation is dangerous, un-

less the coil has been especially constructed for this connection. In the majority of cases, the connecting to earth may be made without danger, because the e.m.f. employed in this case is much less than that which the insulation can resist: taking, for example, a coil giving 40-cm. sparks connected to antenna for wireless telegraphy; thanks to the capacity of the antenna, one rarely obtains sparks greater than 10 cm. between the balls; therefore, the insulation would not be in the least endangered by connecting the pole opposite to the antenna to earth. It would be the same if one was exciting an X-ray tube, the equivalent spark of which is 10 cm. long with a coil giving 25-cm. sparks. In a general manner, one can always connect one terminal to earth when the maximum operating e.m.f. corresponds to half of the maximum e. m.f. which the coil is capable of producing; above this limit, coils especially built for the purpose must be used.

All symmetrical coils when one of their terminals is connected to earth, show a change in the aspect of the spark; it becomes whiter, more crackling, because of the increase in the secondary capacity; it approaches the appearance of sparks from a unipolar coil.

It seems desirable to connect several coils together, so as to increase the available power; there is no precise rule for this case. If the coils were perfect, it would be immaterial whether they were connected in series, or in parallel; since the energy available in each would be added to that of the others, it would be only necessary to consider the exterior circuits. In reality, the phenomena are more complex, and it appears that the parallel connection of secondaries will give unfavorable results, because of the inevitable inequality of the coils, even in the case where it is desired to increase the value of the current; as, for example, when charging large capacity, the series connection appears to give better results. When it is desired to increase the e.m.f. by employing two coils, it is necessary to take the insulation of the coils into account. This connection is only possible for small coils in which the major

insulation between the primary and the secondary is generally considerably greater than is strictly necessary. With large coils, it is not possible, without danger, to exceed the e.m.f. which would be permitted when one of the terminals is grounded.

The primary circuits of the coils should preferably be connected in series, because the interrupters will stand an increase in voltage better than an increase in the value of the current; however, if one is dealing with a battery containing a limited number of cells of large current capacity, it is impossible to do otherwise than to connect the primaries in parallel. Whatever be the connection adopted only one interrupter should be employed, and the change in the coefficient of self-induction should be taken into account, since it requires variation in the capacity of the condenser if the most favorable results are to be obtained. In order to obtain a greater useful effect, it is necessary that the total energy input to the connected primaries should be greater than that which one coil can absorb.

The regulation of interrupters is a very important point, upon which, unfortunately, it is not possible to give general instructions. Referring to Chapter VIII, where a variety of models are discussed, some directions as to their use will be found. It should be borne in mind that the regulation of interrupters is before all a matter of cut and try and of experience, and it is always preferable to follow the instructions given by the builder.

42. Charging large capacities.—This requirement is often met nowadays in wireless telegraphy and the generation of Hertzian waves in general, for the production of Tesla oscillations and in spectroscopy.

When a coil is to charge a large capacity and furnish a spark at each rupture, the condenser to be charged is connected directly to the terminals of the secondary winding, which case is covered by the equations of Colley. Theory and practice both show that the length of the sparks which can be obtained is the more reduced the greater the capacity. If it is desired to determine in

advance the conditions to be fulfilled in order to obtain a given result, it is possible—knowing the coefficient of self-induction of the primary, the capacity of the secondary, the disruptive e.m.f. which corresponds to the desired spark—to use the efficiency equation given in Chapter VI; the maximum secondary e.m.f., E_2 , is:

$$E_2 = I_0 \sqrt{\eta_2 \frac{L}{C}}$$

It should be noted that η_2 is generally smaller than 0.5.

This equation is in error when the secondary capacity is an antenna, because energy is radiated into space, and it is impossible to know the efficiency; the above equation is true only for condensers.

In charging large capacities, it is not necessary to use coils giving very long sparks; it is preferable that the secondary be wound with comparatively large wire, so as to obtain a low resistance. Between two coils having the same coefficient of self-induction in the primary, the one having the lesser secondary resistance should be chosen even though, without capacity, it gives a shorter spark.

Induction coils intended for wireless telegraphy should, for the reason given above, possess other things being equal, a low secondary resistance; they should be very well insulated, since they operate always with one terminal grounded, and also cause high-frequency currents, which are the more destructive for induction coils than low-frequency currents. The smallest fault between two consecutive secondary turns may not be noticed with ordinary discharges, but when operated with condensed sparks, immediately produce a short-circuit.

In spectroscopy, it is also advantageous to employ coils with low-resistance windings; it is never necessary to obtain long sparks, and it is necessary, on the contrary, when condensed sparks are not used, to obtain a sort of a very hot arc.

In laboratories and lecture rooms, it is sometimes necessary to charge large batteries of Leyden jars having a

very large capacity, and it is necessary to obtain sparks of the same length as those which the coil can give alone. In this case, it is impossible to connect the battery directly to the secondary terminals, because then a very short spark would be obtained; it must be charged by means of several successive sparks in such a manner as progressively to elevate its potential to the necessary value. The connections for this procedure are shown in Fig. 102. The interior plates, 2, of the condensers are connected as well as possible to the negative side of the coil (the losses of energy by radiation are less in this case); the exterior plates are connected to the positive pole through a gap formed by a point, p , and a plate, P . The distance between the point, p , and the plate, P , is long

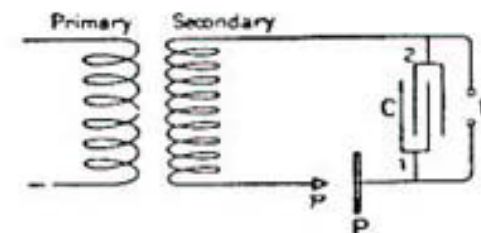

FIG. 102.

enough to give clear white sparks. At each discharge between p and P , the potential of the condensers rises; the sparks at first being very full, become thinner; then, when the disruptive e.m.f. corresponding to the distance, B , is obtained, a burning and luminous spark is formed; the discharges at p , P again become more intense, and the battery is recharged. The number of sparks at p , P , necessary to obtain a discharge at B , depends upon the capacity of the condensers and the spark distance at B . The essential condition to be fulfilled, is that the gap, p , P be very unsymmetrical, so as to prevent the discharge of the condensers into the coil.

43. Radiography and radioscopy.—Radiography and its derivatives, which are often known under the more general name of "radiology," constitute to-day one of the prin-

cial applications of induction coils. The subject is too broad to be treated here; it requires development which extends beyond the domain of the engineer, and since there exist numerous and good works on this subject, it will not be attempted to do more than give a few points which have direct bearing upon the induction coil.

If a cathode tube is placed in shunt with a spark-gap, it is well known that there exists for each degree of vacuum a distance between the electrodes of the gap for which a discharge will be produced with equal facility, either at the spark-gap, or through the tube. This definite length is called the "equivalent resistance of the tube," or, more exactly, the "equivalent spark." Since the nature of the rays emitted varies with the degree of vacuum, it is necessary to know exactly the length of the equivalent spark, and it should always be measured with the same gap; this gap may be formed by two small rods mounted at the terminals of the induction coil, and arranged to allow adjustment of the gap. It is also possible to use a gap consisting of a point and a plate. This is an excellent scheme for temporary installations, because it permits the recognition of the direction of the current, before connecting in the tube; the tube should be connected with its cathode to the plate after having seen that the spark passes from the point to the plate. Care should always be taken to determine the direction of the current, before connecting the cathode tube, because the reversal of the polarity of the tube will damage it.

In a general way, it is known that a tube having a short equivalent spark, emits rays of small penetrative powers which traverse bones with difficulty, and consequently give negatives with very great contrasts. On the contrary, when the equivalent spark increases, the rays become more and more penetrative, the negatives are more gray, but details of the bones are obtained.

The equivalent spark measured between the terminals varies from 2 cm. or 3 cm., and 10 cm. or 15 cm.; it rarely exceeds 20 cm. From this it should not be concluded that

a coil giving 15- or 20-cm. sparks, is sufficient; account must be taken of the requisite power. In France induction coils giving from 25- to 45-cm. sparks are frequently employed; in other countries, notably in Germany, still larger coils are often used; it is difficult to say which is better, because it all depends on the tubes employed.

The length of the equivalent spark being known, it remains to measure the effective value of the current through the tube and the frequency of the discharges, in order to define exactly the conditions of operation. Such complete measurements are rarely made; moreover it is quite difficult to measure alternating currents at this frequency; hot-wire instruments alone are capable of giving indications, and they are rarely sufficiently sensitive. In practice, the mean value of the primary current is measured. This permits one to judge approximately the operating conditions of the coil. The frequency of discharge is not always known; however, with the majority of interrupters, it is quite constant under fixed conditions. It suffices for example, to keep the e.m.f. at the motor terminals of motor-interrupters constant in order to maintain approximately constant speed. Interrupters provided with a tachometer are convenient in this case. With vibrating interrupters, the conditions of operation are determined solely by the voltage of the source and the mean value of the current, so that it is necessary for the operator to have some experience in order to be able to recognize when a favorable adjustment has been obtained.

As means of regulating the current, the ordinary methods are available: Voltage of the source; resistance of the primary, and duration of contact. Use is often made of induction coils in which the primary winding consists of several coils which may be connected in series or in parallel, as mentioned in section No. 27.

In radiography slow interrupters, more or less regular, giving few strong discharges, may be used; but for radioscopy, the speed must be sufficiently high to constantly light the screen. A frequency of from 20 to 25 sparks per

second appears to be a minimum; below this the scintillation of the screen renders observations very difficult and very fatiguing. Also, because of the scintillation, the discharges should be very regular. Among the mercury interrupters which give the best results in this respect, are the turbine interrupters; atonic interrupters are to be preferred among the dry interrupters.*

It is sometimes necessary to connect the positive side of the coil to ground, so as to avoid a shock, which would result from the contact of the patient with the tube; from what was said above, it will be seen that this ground can be made without inconvenience in the majority of cases, since the length of the equivalent spark is rarely greater than half of the maximum spark which the coil can produce.

The equivalent resistance of a cathode tube differs according to the direction of the current; it is a minimum when the electrode, which by construction is destined to be the cathode—that is to say, the electrode having the greater surface—is connected to the negative pole of the coil but the resistance is not infinite in the reverse direction. In some cases there is very little difference. The result of this is that the small value of the e.m.f. produced when the circuit is closed, which is negligible as far as sparks are concerned, may produce in a cathode tube a slight discharge, but sufficient, nevertheless, to produce another source for the emission of X-rays, which may interfere with the image obtained, and also is capable of deteriorating the tube; it is important, therefore, to protect the tube against current produced upon closing the circuit.

Many operators protect their tubes by means of Villard cathodic valves (Fig. 103); these are tubes in which the cathode, *S*, is in the form of a helix of large aluminum wire, and the anode a small disk of the same metal, *a*,

*Electrolytic interrupters are extensively used at present, both in radiology and radiography. They are the most rapid, and can operate with higher current values than others.

placed at the end of a narrow tube. The cathodic valves have the property of being extremely unsymmetrical; when the wire is cathode, the length of the equivalent spark is about a millimeter, while it is about 10 cm. when the wire is anode. It is easily understood that by placing one of these valves in series with the tube to be protected, that the equivalent resistance in the correct direction is but slightly increased, while in the other direction, it is considerably increased. As shown in Fig. 103, the wire, *S*, of the valve should be connected to the anode, *A*, of the tube.

The use of alternating currents is often obligatory, because of the great number of distribution systems which furnish

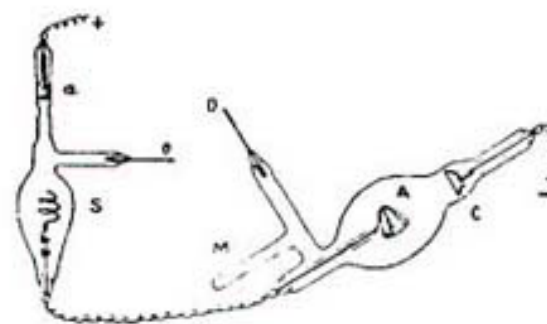

FIG. 103.

alternating current only. In using cathode tubes, it is necessary that the discharges take place in the same direction; therefore, one of the half waves must be suppressed, or the current must be rectified.

In suppressing one of the half-waves, use may be made of an interrupter for alternating current, which gives a single interruption per period; as for example, the Villard interrupter, or the synchronous-motor turbine interrupter. It is also possible to connect in the primary circuit, one or two electrolytic valves, which will allow current only in the direction from lead to aluminum, and offer an almost unsurmountable resistance in the other direction. The use of the cathode valve placed in shunt with the secondary, gives the same results as an aluminum valve

in the primary circuit. The Wehnelt interrupter gives a secondary current which is more or less unsymmetrical, according to the conditions of the circuit; when it is used, it is well to connect a cathode valve in the secondary to eliminate more completely the reverse current. By employing rectifiers, the available power is increased, since both half-waves are utilized. Mechanical rectifiers have been practically abandoned; the same result can be obtained, either with electrolytic valves connected like a Wheatstone bridge as was shown in section 37, or with four Villard cathode valves connected in the same manner, the cathode tube being connected on the diagonal.

Whatever be the method preferred for rectifying the current, the use of alternating current presents itself in two

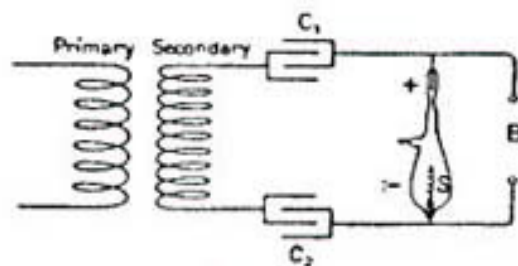

FIG. 104.

forms: Employing an induction coil as a simple transformer; or as a coil with an interrupter. The first solution is rarely applicable, because the transformation ratio of ordinary coils is too small. For instance, a coil giving 40-cm. sparks, having a transformation ratio of from 150 to 200, and a coefficient of self-induction of 0.03 henry, when connected to a 200-volt, 50-cycle circuit, will give only from 16,000 to 22,000 volts; that is to say, a spark from 2 cm. to 3 cm. long at the most. This method is, therefore, applicable only with special coils having large transformation ratios.

It is possible to greatly increase the e.m.f. by using an arrangement of Villard (Fig. 104). The secondary terminals are connected to two condensers of considerable capacity; the other set of condensers being connected by

a tube, or by a spark-gap, *B*; the alternating discharges of the coil traverse the condensers and give sparks of certain length at *B*. If a cathode valve is connected in shunt with *B*, it will form a short-circuit for currents in one direction, in the same manner that the sparks will become united directly; but, furthermore, because of a phenomena as yet little known, the length of the sparks which may be obtained in *B* will be increased considerably; they are sometimes doubled.

The direct use of alternating current is not general. In most cases recourse is had to interrupters, so as to raise the secondary e.m.f. to a sufficiently high value.

44. Ignition.—The spark furnishes a convenient means for igniting explosive mixtures; it is used in laboratories for gas analysis with the eudiometer; it is used for lighting gas lamps, but at present the most important field is the ignition of the explosive mixture in gas engines.

The general principle of operation of these engines, especially the four-cycle type, which is almost universally employed to-day, is well known. After the explosion, the piston is driven forward; the cylinder is filled with burnt gas; when it arrives at the end of the stroke, a valve is opened, and the piston returning, drives out the gas. Another stroke forward is produced by energy stored in the fly-wheel, after which by a suitable valve gear, the exhaust valve is closed, and the admission valve opened; during this stroke the piston draws in the explosive mixture, then it returns, still driven by the fly-wheel. During the third stroke, the explosive mixture is compressed in the cylinder, and at the moment when the pressure is a maximum, the ignition must be produced; the explosion drives the piston forward, producing the energy of the motor.

The moment of ignition must be accurately determined, otherwise bad results will be obtained. Fig. 105 shows an indicator diagram of a spirit motor taken by Hospitalier-Carpentier for three ignition points. In curve 3, the ignition is produced too soon, the spark is too advanced;

the curve shows distinctly that the ignition point occurs before the end of the stroke; the maximum pressure attained is considerable. It produces a violent explosion, dangerous for the motor, and in spite of this, the area of the diagram, which is well known to be proportional to the energy developed, is less than that obtained with correct ignition (curve 2). If, on the contrary, the ignition

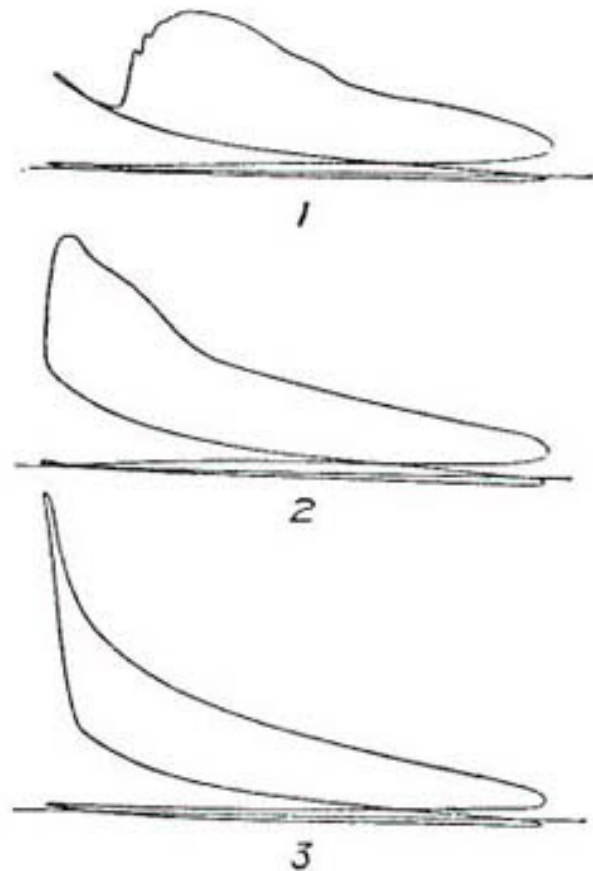

FIG. 105.

1. Late Ignition. 2. Correct Ignition. 3. Early Ignition.

is late (curve 1) the spark takes place when the piston is on its forward stroke, the pressure of the mixture is already diminished, the area of the diagram is reduced; at the end of the forward stroke, the pressure of the burnt gas is still great enough at the moment when the exhaust valve opens, to let out gases which are too hot and which have not had time to expand and produce useful work.

The problem may be stated as follows: To produce at a precise moment in the travel of the piston, a spark capable of igniting the mixture. The moment when the spark should take place varies with the motor and with its speed. The ignition of the mixture is not instantaneous; it takes place at a speed of about 5 meters per second, so that in order to obtain a maximum effect, the spark must take place a little before the passage of the dead point. For a given motor and mixture, this advance has constant value; however, for different speeds, the advance of the spark must be changed; this necessitates the adjustment of the advance wheel when the motor is in operation. In reality, motors of low or mean speed, in order to give good results, should have a nearly constant advance of the spark; if the majority of these motors are provided with a device for varying the advance, it is because the spark does not take place at the moment when the cam produces the rupture; there is a retard which varies according to the circumstances.

The precision with which the spark should be produced is for modern motors of the order of a thousandth of a second; therefore, special precautions must be taken to obtain sparks which are very regular.

The moment when the spark should be produced is determined by a mechanism, generally a cam, which closes the primary circuit of an induction coil provided with an ordinary interrupter, or the coil is not interrupted, and the cam produces the rupture.

Considering the first arrangement (Fig. 106), the circuit is closed, the current established in the primary, and the attraction of the armature of the interrupter opens the circuit, and a spark is produced. The conditions to be fulfilled are as follows: The cam must hold the circuit closed for a time sufficient to allow the current to be established in the coil; the interrupter should run perfectly uniformly, so that the interval of the closing of the circuit by the cam and the spark will be rigorously constant; if this is not the case, the spark will take place too soon

or too late, producing ignition under conditions disadvantageous to the motor.

In order to obtain good results, two methods are used: The use of atonic interrupters, which interrupt the current at the end of equal periods when the conditions of the circuit do not change; or the utilization of very high speed, vibrating interrupters, so that the retard or advance produced by an irregular spark will remain within suitable limits of time.

The ordinary vibrating interrupters have the serious defect of remaining in vibration during the interval of

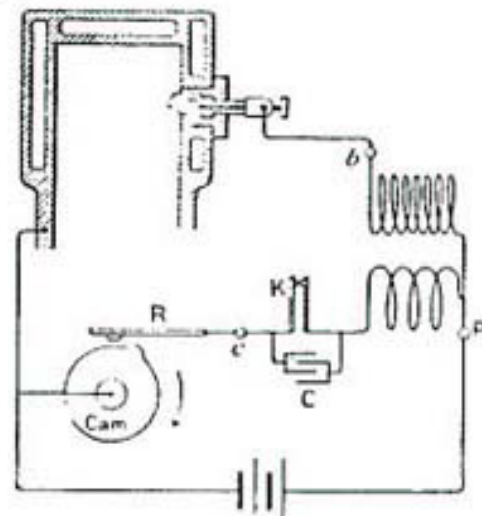

FIG. 106.

two closures by the cam, so that the rupture is in advance or retard, according as the closure is produced during the movement of the hammer toward the core, or inversely; the spark is very weak or zero in the first case, because the current has not time to attain a sufficient value. It is seen that this inconvenience can only be avoided by using very high speed interrupters.

The spark advance lever permits the variation of the instant of closing the circuit, so that the spark always takes place at the desired moment; according to the duration of the establishment of current in the coil, it is pos-

sible to have a greater or less apparent advance, and the closing of the circuit may take place long before the end of the compression stroke, while the spark is produced at the dead point. When the speed changes, the constant duration of current establishment corresponds to a different fraction of the stroke; therefore, it is necessary to vary the apparent advance in order to produce the spark at the same point in the stroke; in starting, it is necessary

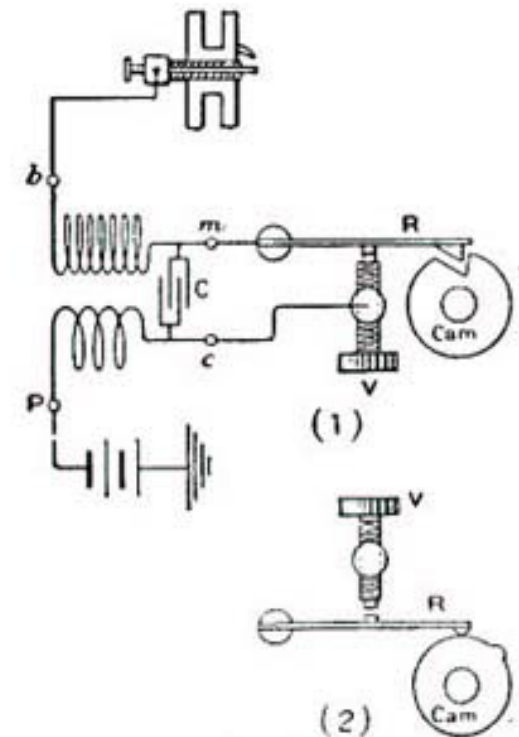

FIG. 107.

to give the spark a large apparent retard, so as to avoid the possibility of reversing the engine.

When the rupture is produced by a cam, the scheme is that shown in Fig. 107-1. The primary circuit is closed by the spring, *R*, which rests against a screw, *V*; at the end of a time, more or less long, according to the speed of the motor, the spring, *R*, suddenly raised by the cam, leaves the screw and the circuit is broken, because of connection on the inside of the coil, the condenser, *C*, is

connected between the points of rupture, thus far everything is exactly as in ordinary coils, except that there is only one spark per revolution. The above system is that which has been used by the Dion automobile; the current is established by the shock of the spring on the screw; on the other hand, in the Aster system the contact is established by the raising of the spring by the cam (Fig. 107-2). In other systems, the cam is replaced by an insulating

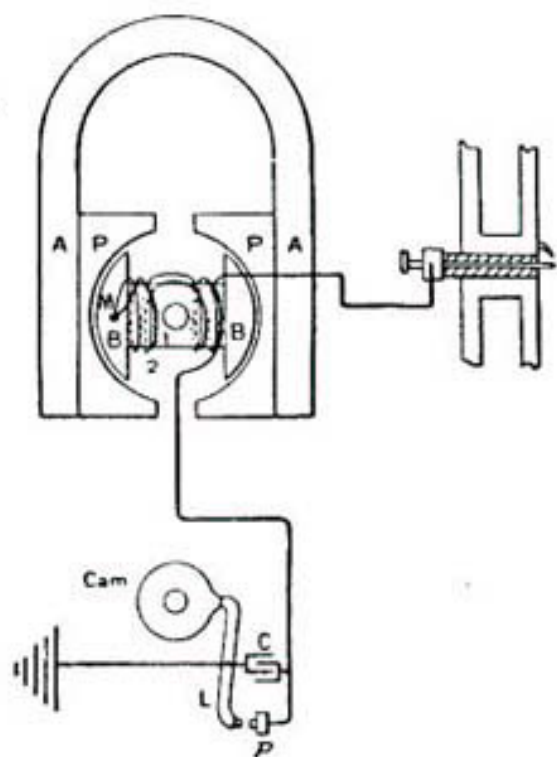

FIG. 108.

disk, provided with metallic sectors against which a spring rests.

In such systems the rupture is produced by the movement of the cam. There is no need to advance the spark, and in practice, the motors which are provided with this arrangement, generally have a fixed advance; there being provided a constant retard to be used when starting.

Spark coils for motors have taken a great many forms.

We will not describe them here, but will limit ourselves to general instructions as to their operation.

Among the systems derived from the above, we can mention that which is based on the "extra current" of rupture. The coil employed is an induction coil, the circuit of which is closed by a contact inside of the cylinder instead of the spark-plug; the cam produces a sudden separation of the contact pieces, so that a spark of "extra current" passes between them in the cylinder; with this arrangement the current is often furnished by a small magneto.

A combination system of coil and magneto is now often employed; the first appears to be due to Simms-Bosch firm. The induction coil (Fig. 108) has two circuits, primary and secondary, wound on the armature, *B*, of a small magneto driven by the motor itself. The primary circuit is closed by a spring contact, *L-p*, which is opened abruptly by a cam at each revolution of the shaft; under these conditions, the current produced by the rotation of the magneto is interrupted at the moment when its value is a maximum; the condenser, *C*, being placed in shunt with the interrupter, everything takes place as in an ordinary induction coil; in the secondary, *2*, is generated a high value of e.m.f., which is added to the much smaller e.m.f. generated by the rotation of the circuit, *2*. This system is very simple; it does away with the use of a primary or secondary battery; its installation is very easy, since it requires only one insulated wire between the free terminal of the secondary and the spark-plug.

In the Eisemann system, the coil and magneto are separate (Fig. 109). The armature of the magneto is short-circuited during the major portion of the stroke; at the moment when the cam passes, the short-circuit is opened, and the "extra current" in the primary, *1*, of the coil produces by induction in the secondary, *2*, an e.m.f. sufficient to give a spark several millimeters long.

The magneto systems have the advantage of always being ready. It is not necessary to trouble one's self as

to the condition of primary batteries or the charge of storage batteries; on the other hand, the magneto often becomes demagnetized, thus causing the same disturbances.

All systems using an induction coil, or more generally high-tension in which the spark jumps between two points at a fixed distance, require the use of a spark plug. The plug contains two metallic wires, one insulated, the other

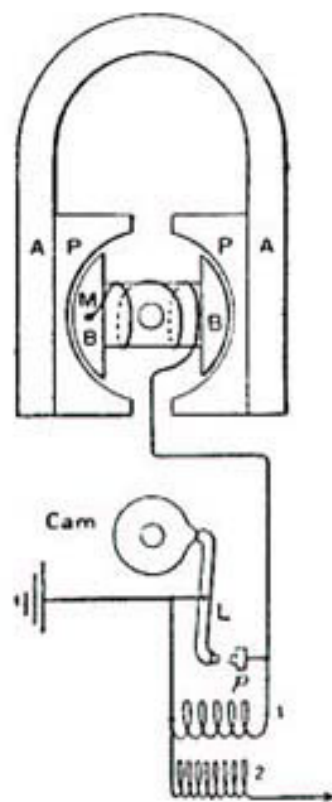

FIG. 109

connected to the frame of the engine, between which is formed a spark of from 0.5 to 1 millimeter in length at the most. The insulation between the two wires is generally of porcelain; although mica is also employed. The types of plugs are numerous, and the differences between them are often of little importance. They are generally for the object of preventing the cracking or breaking of the plug.

In spite of the short distance between the wires of the spark-plug, the spark encounters a certain resistance in overcoming this distance, because of the compression of the gas. The equivalent spark, in which air at atmospheric pressure may be ten times longer than the spark in the compressed gas as can be easily verified by a spark gap placed in shunt with the spark-plug.

The spark which is formed in the compressed gas is always a high-frequency spark; this can be shown by the use of the loop of wire as described above, in section 22.

The plugs become covered in time with a slightly conducting layer of black smoke and oil; the result being that the current encounters a path of little resistance which reduces the e.m.f. much below the disruptive value and when the spark is not produced ignition is impossible. This action is greatly accelerated when the combustion is not perfect. An accidental observation has shown that, nevertheless, under these conditions a spark at the plug may be obtained if the plug is connected to this coil by a broken conductor, so that a spark of from 1 to 2 millimeters is formed in the circuit. The phenomena is due to the fact that the auxiliary spark substitutes for the relatively slow variation of potential, the abrupt variation which causes the discharge at the plug; the phenomenon is analogous to that produced with a plate of filings which was formerly used for increasing the length of sparks; an alternating current of ordinary frequency can traverse the plate without affecting the exterior, while the discharge of a Leyden jar produces sparks at the surface. (B No. 103.)

45. **Miscellaneous applications.**—Induction coils are used for a great many experiments in lecture courses and in the laboratory; the general directions given in the preceding chapters cover many of these uses.

The operation of Geissler tubes ordinarily requires small coils, or when large coils must be used, their power must be greatly reduced, otherwise the tubes may be deteriorated. In making the Crookes experiments greater power is necessary; however, the most of them can be made with coils giving at the most 10-cm. sparks.

In all experiments with Geissler tubes or Crookes tubes as with Röntgen tubes, care should be taken to fasten the wires which connect the electrodes to the coil, and they should be removed as far as possible from the rest of the tube, so as to avoid a spark between the wire and another part of the glass, which would puncture the tube and put it immediately out of service.

The production of ozone requires a coil proportionate to the dimensions of the ozonizer employed. The operation consists in passing a certain quantity of air or oxygen between the electrodes of the condenser charged to a potential high enough to produce brush discharge. The potential should never be raised high enough to produce sparks; consequently, the coil to be employed should be proportionate to the condenser; the larger the condenser, the more powerful the coil, but also the greater the quantity of ozone furnished.

The classic experiment of puncturing glass, is often made with an induction coil. When a large coil is used, it is possible to puncture blocks of glass several centimeters in thickness; a coil giving from 40- to 50-cm. sparks, can, for example, puncture a block several centimeters thick. When the experiment is made with a small coil and a thin plate of glass, the precautions to be taken are simple; on each side of the glass plate opposite each other, are placed two metallic points, which are connected to the coil. When the thickness of the glass increases, precautions must be taken to prevent discharge over the surface. The sparks taking this course in preference to piercing the glass. The best means, and the most sure, to employ in this case, consists in drilling two holes in the surface of the glass, scarcely 1 millimeter deep and opposite each other; then, after placing the points, the entire outfit is immersed in mineral oil or petroleum; the vessel which contains the oil should be large enough to permit the entrance of the terminals without danger of discharge across them; otherwise, they must be protected by glass tubes. In this way the surface discharges, which ordinarily prevent the puncture of the glass, are easily avoided.

Care should always be taken to thoroughly dry the block of glass, so as to avoid surface discharge.

In making this experiment, it is generally advisable to place a spark-gap in shunt with the glass to be punctured; the electrodes being separated by a distance equal to the maximum spark which the coil can give. This precaution is taken to prevent the damaging of the coil by the discharge when the spark is formed without piercing the glass. The effectiveness of this device has been demonstrated; it is true also that it does not do any harm. That which we know of coils shows that the danger of a puncture or of a short-circuit of the coils, is more when the coil produces oscillatory discharges, even though they be shorter than when the spark cannot be formed; it appears that the terminals of the coil generally constitute a sufficiently effective lightning arrester.

A very extended application of coils concerning which it is, unfortunately, impossible to give any very useful directions is that of medical coils, in which current is used to produce shocks in the human organism. For this use the coils should be of low power and fed with low value of currents. The models most often used have no condensers; the interrupters are of the spring type, and generally produce a considerable spark at the rupture, so that the maximum e.m.f. generated in the secondary is low enough not to be dangerous. From that which we have seen in section 7, it is indeed difficult to define the current which should be applied in this way to patients, and the proceeding is entirely empirical. Some doctors in order to render the results more comparable, use coils with condensers employing very large capacities, so as to lower the secondary e.m.f., and to prevent the disturbance which results from the spark at the rupture. Probably the same results can be obtained by shunting the interrupter with a low resistance. The metal screen which serves to regulate the action of small medical coils, plays an analogous rôle; the currents produced in it oppose the variation of the primary current. It appears that real progress can be made in this line, if the problem is once properly stated.

CHAPTER XI.

BIBLIOGRAPHY.

In this chapter, the majority of articles on the induction coil, which have appeared, are arranged in chronological order, and wherever it is necessary, a short synopsis of the original part of each one is given. Here will be found the analysis of the development of the ideas of the various authors, which it was impossible to give space to in the preceding chapters.

The symbols used by the authors have been changed to correspond with the style of this book as far as possible, so as to facilitate the reading.

1. HENRY, Professor of Natural Philosophy in the College of New Jersey, Princeton.—*American Journal of Science*, July 1832. First article by Henry referred to by himself in the *Sturgeon's Annals of Electricity*, 1837, p. 282.

2. DAL NEGRO.—*Bibliothèque Universelle*, 1833, vol. 2, p. 394; referred to by Masson.

3. HENRY.—Communication to the American Philosophical Society, Philadelphia, January 16, 1835. Reprinted in *Sturgeon's Annals of Electricity*, 1837, p. 282.

4. A. MASSON.—"The induction of a current on itself." *Annales de Physique et Chimie*, 2d series, vol. LXVI, 1837, p. 5.

5. PAGE.—"Method of increasing shocks and experiments with Professor Henry's apparatus for obtaining sparks and shocks from the calorimotor." *Sturgeon's Annals of Electricity*, 1837, p. 290.

6. CALLAN.—"On the best method of making an electromagnet for electric purposes." *Sturgeon's Annals of Electricity*, 1837, p. 295.

7. STURGEON.—Paper read before the Electrical Society in London. *Sturgeon's Annals of Electricity*, 1837, p. 477.

8. HENRY.—Article on the study of electricity and magnetism. *Philosophical Magazine*, vol. 16, 1840, p. 200.

9. MASSON AND BREQUET, JR.—Academy of Sciences, August 23, 1841. *Annales de Physique et Chimie*, 3d series, vol. IV, 1842, p. 129.

10. FIZEAU.—*Comptes rendus*, March 7, 1853, vol. XXXVI, p. 418.

11. POGGENDORFF.—Academy of Sciences in Berlin, December 17, 1854, January 8, 1855, and March 29, 1855. Discussion by Verdet: *Annales de Physique et Chimie*, 3d series, vol. XLIV, 1855, p. 375.

12. FOUCAULT.—*Comptes rendus*, vol. XLII, 1856, p. 215; vol. XLIII, July 7, 1856, p. 44. *Société philomathique*, April 19, 1856. All these papers are reprinted in the *Recueil des travaux de Leon Foucault*, 1878.

13. FOUCAULT.—*Procès-verbaux de la Société philomathique*, 1857, p. 105.

14. JEAN.—*Comptes rendus*, vol. XLVI, 1858, p. 186.

15. DUMAS.—Report on the purposes of the Volta prize. *Moniteur universel*, September 13, 1864.

16. PAGE.—"History of Induction," pamphlet published in 1867.

17. DU MONCEL.—"Notice sur l'appareil d'induction électrique de Ruhmkorff," 5th edition, 1867, Gauthier-Villars.

18. X.—*Les Mondes*, vol. 27, 1872, p. 60.

19. RUHKORFF.—*Les Mondes*, vol. 27, 1872, p. 60. An answer to the preceding article.

20. DU MONCEL.—"Exposé des applications de l'Électricité," vol. II, p. 238, and following E. Lacroix, Paris, 1873.

21. L. MOUTON.—Thesis, Paris, 1876.

An experimental study of the phenomena of electrodynamic induction. Observes the oscillations of the secondary e.m.f. with the aid of a rotating contact breaker;

the first application of this method in electricity. The coil studied by Mouton had no primary condenser, the oscillations being due, therefore, entirely to the secondary.

22. P. WARD.—*English Mechanic*, 1886.

23. SPOTTISWOODE.—*Philosophical Magazine*, January, 1887.

24. FLEMING.—*The Electrician*, London, May 31, 1889, p. 88.

A tentative mathematical theory which leads to erroneous conclusions.

25. R. COLLEY.—*Wiedemann Annalen*, vol. 44, p. 109, 1891.

The most important mathematical study published on this subject. A work which, unfortunately, is little known. Starting with well-known differential equations, the author calculates the results: First, for the primary circuit alone, taking into account its capacity and coefficient of self-induction; the difference of potential at the terminals of the condenser and the primary current, have the following values:

$$(1) \quad E_1 = I_0 \frac{1}{\beta G} e^{-\alpha t} \sin \beta t,$$

$$(2) \quad I = I_0 e^{-\alpha t} \left(\cos \beta t - \frac{\alpha}{\beta} \sin \beta t \right) \quad (\text{see Fig. 10}),$$

$$\alpha = \frac{R}{2L} \text{ and } \beta = \sqrt{\frac{1}{LC} - \frac{R^2}{4L^2}}.$$

Second, for a coil with a condenser short-circuited and having, therefore, an infinite secondary capacity. The secondary current i is given thus:

$$(3) \quad i = \frac{M I_0}{l} (e^{-\alpha t} \cos \beta t - e^{-2\alpha t}) \quad (\text{see Fig. 11}),$$

$$\gamma = \frac{r}{2l}$$

Third, for a coil with the secondary closed by a capacity c , without taking into account the capacity of the secondary winding, and supposing that there exists no current in this circuit, except the charging current of the condenser c . The calculation in this case gives three solutions, according to the resistance r of the secondary circuit:

$$r^2 > 2 \frac{l}{c}$$

When $r^2 \geq 2 \frac{l}{c}$, the secondary current is composed of a decreasing current superposed on an oscillatory current also decreasing. We have also, calling δ the term

$$\delta = \sqrt{\frac{r^2}{4l^2} - \frac{1}{lc}}$$

the difference of potential at the secondary terminals, E_2 , and the value of the secondary current i :

$$(a) \quad r^2 > 2 \frac{l}{c}$$

$$(4) \quad E_2 = \frac{M I_0}{lc} \left(\frac{1}{2\delta} e^{-(\gamma-\delta)t} - e^{-(\gamma+\delta)t} - \frac{1}{\beta} e^{-\alpha t} \sin \beta t \right),$$

$$(5) \quad i = \frac{M I_0}{l} \left(\frac{\gamma-\delta}{2\delta} e^{-(\gamma-\delta)t} - \frac{\gamma+\delta}{2\delta} e^{-(\gamma+\delta)t} + e^{-\alpha t} \cos \beta t \right)$$

$$(b) \quad r^2 = 2 \frac{l}{c}$$

$$(6) \quad E_2 = \frac{M I_0}{lc} \left(t e^{-\alpha t} - \frac{1}{\beta} e^{-\alpha t} \sin \beta t \right)$$

$$(7) \quad i = \frac{M I_0}{l} [(\gamma t - 1) e^{-\alpha t} + e^{-\alpha t} \cos \beta t] \quad (\text{see Fig. 12}).$$

Finally, when $r^2 < 2 \frac{l}{c}$, there is a superposition of two oscillatory currents, the period of different frequency and different damping. We have,

$$\delta' = \sqrt{\frac{1}{lc} - \frac{r^2}{4P^2}}$$

$$(c) \quad r^2 < 2 \frac{l}{c}$$

$$(8) \quad E_2 = \frac{M I_0}{lc} \frac{\beta^2}{\beta^2 - \delta'^2} \left(\frac{1}{\delta'} e^{-\delta' t} \sin \delta' t - \frac{1}{\beta} e^{-\delta t} \sin \beta t \right)$$

(see Fig. 26).

$$(9) \quad i = \frac{M I_0}{l} \frac{\beta^2}{\beta^2 - \delta'^2} (-e^{-\delta' t} \cos \delta' t + e^{-\delta t} \cos \beta t)$$

(see Fig. 13).

Colley verifies this theory by observations on the coil with a revolving mirror; he gives three very good pictures of the phenomena. Finally, he also makes some attempts to verify directly the form of the current with the aid of an apparatus which he calls an "oscillometer," which is, although very imperfect, the first of the oscillographs.

26. TOM MOLL.—*Wiedemann Annalen, Beiblätter*, vol. XV, 1891, p. 129.

Measures the number and the intervals between the sparks with the aid of the revolving mirror and photography. Finds that this interval increases as the square root of the length of the sparks, and also counts the sparks by making them pierce a rapidly moving paper.

27. ARMSTRONG.—*Electrical Review*, London, 1892, p. 113. Royal Society of London, May 18, 1892.

Makes some experiments in the connections of coils. Connects as many as six coils of 26-cm. sparks in parallel. Measurements quite inaccurate; the study is more or less qualitative.

28. H. ARMAGNAT.—*Industrie électrique*, March 25, 1894, p. 117.

Calculates the e.m.f. in the two circuits of a coil by supposing the secondary reaction to be zero. This e.m.f. has for a maximum value

$$E_2 = \frac{M}{\sqrt{cL}} I_0, \quad E_2 = \frac{L}{\sqrt{cL}} I_0;$$

their ratio is equal to $\frac{M}{L}$, that is to say, the ratio transforma-

tion of the coil. Shows that the high value of E_2 requires very good insulation of the primary and of the secondary. Notes the importance of high initial speed of separation of the points of contact.

29. F. G. ALLSOP.—*Induction coils and coil making*. Spon, London, 1896.

30. LEWIS WRIGHT.—*The induction coil in practical work*. Macmillan, London, 1897.

31. NORTON & LAWRENCE.—*Electrical World*, New York, March 6, 1897, p. 327.

A condenser of great capacity is connected on one side to the primary of the coil, and to one of the terminals of a lighting circuit, having an e.m.f. of 100 or 200 volts; the other terminal of the condenser is connected alternately by means of a rotating commutator to the other terminal of the circuit and the terminal of the primary coil (Fig. 100). The discharge of the condenser to the primary sets up oscillations and produces currents in the secondary. The authors obtained in this manner with a 15-cm. coil and a condenser having a capacity of 25 microfarads, 5-cm. sparks on a 200-volt circuit; replacing the primary winding of the coil by another having only 70 turns of large wire, they obtain sparks 15 cm. long.

32. OBERBECK.—*Wiedemann Annalen*, vol. LXII, 1897, p. 109.

Tries to measure directly the difference of potential across the secondary by connecting one of the terminals of the circuit to ground and the other to an insulated brass

sphere. A point placed before the sphere at an adjustable distance, discharges the sphere when the difference of potential attains a certain value. Observes that the relation between the potential difference at the terminals of the two circuits, primary and secondary, is about constant, it diminishes when the speed of the interruption increases.

33. B. WALTER. — *Wiedemann Annalen*, vol. LXII, 1897, p. 300.

Gives as above (No. 28) the simplified theory of the induction coil, including the secondary reaction. Verifies the theory by observing the form of the primary current with the aid of a Braun cathode tube. Points out the fact that the damping of oscillations at the rupture is very much greater than the calculations would indicate.

34. ARONS. — *Wiedemann Annalen*, vol. LXIII, 1897, p. 177.

Gives the following empirical law for expressing the resistance of the rupture spark:

$$R' = R_0 \frac{\tau}{\tau - t}$$

R' being the total resistance of the circuit, the spark included at the time t , R_0 the initial resistance before the rupture, and τ the time which the rupture lasts between R_0 and R' equal to infinity; the time, t , varies from 0 to τ .

Beginning with this expression, he calculates the value of the current I and the e.m.f. of self-induction as the function of t :

$$I = \frac{E}{R_0} \frac{L}{L - \tau K_0} \left[\left(1 - \frac{t}{\tau} \right)^{\frac{R_0 t}{L}} - \tau \frac{R_0}{L} + \frac{R_0}{L} t \right]$$

$$-L \frac{dI}{dt} = E \frac{L}{L - \tau K_0} \left[\left(1 - \frac{t}{\tau} \right)^{\frac{R_0 t}{L}} - 1 \right]$$

35. E. THOMSON. — *The Electrical Engineer*, New York, vol. XXIV, July 29, 1897, p. 77.

Shows an arrangement of an induction coil intended to reinforce the action of the secondary currents. The coil has three circuits: The first is fed directly from a 100-volt circuit. The rupture of this circuit produces in a secondary circuit of heavy wire, a very high value of current. This one is in turn interrupted by a second interrupter at the moment of its maximum value. It is the rupture of the second current which produces the high e.m.f. in the third circuit, which is of very fine wire.

36. TESLA. — *The Electrical Review*, London, September, 10, 1897, p. 327.

Describes an electric oscillator formed by an ordinary induction coil excited by discharges of a condenser of large capacity. The arrangement is the same as that of Norton & Lawrence (B. No. 31), but the rotating commutator is replaced by an automatic system. The model shown at this time gave sparks 30 cm. long, with a power consumption of 10 watts (see Fig. 100).

37. THOMAS GRAY. — *Industrie électrique*, February 25, 1898, p. 548.

Measures the difference of potential necessary to produce a spark in air between two plates, at a pressure of 760 millimeters (see Fig. 49).

38. C. E. SKINNER. — *Electrical World*, New York, March 18, 1898, p. 301.

Measures the e.m.f. of a high tension transformer, and determines the corresponding disruptive distances between annealed points. The transformer gives a practically sinusoidal current wave. The figures indicated by the author are the mean effective values of e.m.f.; to obtain the disruptive voltages, they should, therefore, all be multiplied by $\sqrt{2}$ (see Figs. 49 and 50).

39. H. ARMAGNAT. — *Eclairage électrique*, vol. XV, April 9, 1898, p. 52.

Discusses the Walter article (B. No. 33) and calls attention to some new experiments: The measurement of the

difference of primary potential by aid of a spark micrometer in shunt with a condenser. This difference of potential decreases when the secondary is in place, even when there are no sparks. Gives the curve of spark length as a function of the maximum values of primary current. Shows the presence of high frequency oscillations in the sparks by the use of a loop connected in the circuit (see p. 80). Calls attention to the existence of an optimum capacity which varies with the coil and the interrupter employed.

40. OBERBECK.—*Wiedemann Annalen*, vol. LXIV, April, 1898, p. 193.

Discusses the equations of Colley (No. 25) with the hypothesis that the resistance is zero for the two circuits, which leads to:

$$(1) \quad E_2 = -I_0 \sqrt{\frac{L}{C}}$$

if the secondary capacity is negligible;

$$(2) \quad E_2 = -\frac{I_0}{2} \sqrt{\frac{L}{C}}$$

if there is resonance between the primary and secondary, $LC = l^2$, or,

$$(3) \quad E_2 = -I_0 \sqrt{\frac{L}{C}}$$

if the secondary capacity is very great.

Studies the disruptive voltages under different conditions. Finds by extrapolation that about 200,000 volts is necessary in order to obtain 1 meter spark between a blunt negative point and a positive conductor. Thinks that the spark discharges and the brush discharges are two distinct phenomena.

41. T. MIZUNO.—*Philosophical Magazine*, vol. XLV, May, 1898, p. 447.

One of the most important experimental researches made

on the induction coil. By a series of systematic measurements, Mizuno puts in evidence the fact, little known before, that for a given coil and a definite current value, there is a definite value of primary capacity which gives the maximum length of sparks in the secondary; this value is the optimum capacity; above or below this, the length of sparks decreases. The tables in the curve which he gives, shows clearly that the optimum capacity varies with the value of the current (see Fig. 18).

42. W. P. BOYNTON.—*Philosophical Magazine*, vol. XLVI, September, 1898, p. 312.

A quantitative study of the high frequency induction coil. Calculations and test on a Tesla transformer.

43. B. WALTER.—*Wiedemann Annalen*, vol. LXVI, 1898, p. 623.

Studies the secondary capacity of a coil by observing the oscillations of the field created by the coil; this capacity is 1.1×10^6 microfarad, the coefficient of self-induction being from 380 to 620 henrys, according to the saturation of the iron; Oberbeck obtained by calculation, 450 times greater value for the same coil. The study of another coil brings Walter to the conclusion that the secondary oscillations predominate in large coils. (The soundness of this opinion is questionable, the curves on which they rest appear to show a fault in the coil.) He attributes great importance to a damping factor of the oscillations which has a higher value than that which he assigns it in the calculations.

44. A. WEHNELT.—*Electrotechnische Zeitschrift*, Berlin, January 26, 1899.

The first description of the electrolytic interrupter.

45. D'ARSONVAL.—*Comptes rendus*, February 27, 1899.

Calls attention to the Wehnelt interrupter and gives some of its characteristics.

46. H. PELLAT.—*Comptes rendus*, vol. CXXVIII, March 20, 1898, p. 732.

Notes the increase in the mean current value when he introduces the primary of a coil in the circuit of a Wehnelt interrupter.

47. S. THOMPSON.—*The Electrician*, London, vol. XVIII, March 25, 1899, p. 471.

Increase in the pressure of the electrolyte in the Wehnelt interrupter diminishes the frequency of the interruptions and increases the mean value of the current.

48. TESLA.—*The Electrical Review*, New York, May 29, 1899.

Review of recent works by Tesla. Points out the fact that the results obtained are better when the secondary wire of the transformer and the high frequency transformer has a length equal to one-quarter of the length of the oscillations.

49. OBERBECK.—*Wiedemann Annalen*, March, 1899, p. 592.

Measures the disruptive voltage between the point and the plate up to 15 cm. distance, it is more advantageous to have the point negative and the plate positive; above that the disruptive voltage is less when the point is positive.

50. A. BLONDEL.—*Comptes rendus*, vol. CXXVIII, April 4, 1899, p. 877.

Studies with an oscillograph, the current and the difference of potential between the terminals of an induction coil having a coefficient of self-induction σ from 0.2 to 0.3 henry. Assumes that the energy stored in the coil goes to charge an electrolytic condenser formed at the anode, and that this is destroyed by the rupture spark.

51. P. BARY.—*Comptes rendus*, vol. CXXVIII, April 10, 1899, p. 925.

Observes three phases in the operation of Wehnelt interrupters; simple electrolysis at low voltage; the Wehnelt phenomena for the mean values; finally, the phenomena described by Messrs. Violle & Chassigny, that is to say, the incandescence of the platinum wire in the liquid. Gives a chart showing the limits of the different phases obtained by varying the resistance and coefficient of self-induction of the circuit (see Fig. 47).

52. A. LE ROY.—*Comptes rendus*, vol. CXXVIII, April 10, 1899, p. 925.

The decrease and increase of pressure causes the Wehnelt phenomena to cease.

53. H. ARMAGNAT.—*Eclairage électrique*, vol. XIX, April 15, 1899, p. 45.

Indicates the form of the primary current in a coil operated with a Wehnelt interrupter. Observations made with an Abraham rheograph (see Fig. 44).

54. KALLIR & EICHBERG.—*Zeitschrift für Electrotechnik*, April 16, 1899.

Study the operation of a Wehnelt interrupter using alternating current. With higher resistance in the circuit, there is a uni-directional discharge; with a smaller resistance, the number of discharges decreases, with an inductive resistance the effect is more intense in one half-wave than in the other.

55. J. CARPENTIER.—*Comptes rendus*, vol. CXXVIII, April 17, 1899, p. 987.

Describes a model of the Wehnelt interrupter operating at low voltage with a warm electrolyte.

56. H. ARMAGNAT.—*Comptes rendus*, vol. CXXVIII, April 17, 1899, p. 988.

Shows that there are no oscillations accompanying the rupture of current by a Wehnelt interrupter, while on the contrary the oscillations appear as soon as capacity is connected to the terminals.

Explains the phenomena entirely by the calorific action, electrolysis and the capacity of polarization playing insignificant rôles.

The incandescence of the gas gives only the pink color observed at the anode; it is caused by the rupture spark which is formed in the envelope of steam about the anode.

as soon as $\frac{dI}{dt}$ is great enough.

The e.m.f. generated in the secondary is proportional to the ratio of the number of secondary turns to the number of primary turns.

57. WALTER.—*Wiedemann Annalen*, vol. XLVI, 1899, p. 636.

Photographs the spark on a sensitive plate, moving it parallel with itself; under these conditions each discharge is decomposed, and it seems that it corresponds to three or four sparks in the same direction. Before the complete formation of the spark there is produced several attempts which manifest themselves at the poles in the form of brush discharge, the length of which increases until the spark is formed.

58. H. TH. SIMON.—*Wiedemann Annalen*, vol. LXVIII, June 1899, p. 273.

Divides the period of the Wehnelt interrupter into two parts: The first T_1 , through which there is an electric current; the second T_2 is that of the interruption. For a given interrupter and a constant temperature of electrolyte, this second term is a constant, $T_2 = C_2$. Suppose on the other hand, that a certain constant quantity of heat is necessary in order to produce an interruption,

$$\int_0^{T_1} K P dt = C_1,$$

and if the resistance of the circuit is constant,

$$I = \frac{E}{R} \left(1 - e^{-\frac{R}{L}t}\right)$$

we can write,

$$T_1 = \frac{3}{2} \frac{L}{R} + \frac{C_1 R}{E^2}.$$

total period is

$$T = \frac{3L}{2R} + C_2 + \frac{C_1 R}{E^2} \text{ or } A + \frac{B}{E^2}.$$

59. H. TH. SIMON.—*Wiedemann Annalen*, vol. LXVIII, April 19, 1899, p. 860.

German patent relative to the symmetrical electrolytic interrupters.

60. H. ABRAHAM.—*Société française de Physique*, May 5, 1899, Bulletin, p. 70.

Charges a condenser with the aid of a high tension transformer and observes photographically the discharge of the condenser between the two electrodes. The frequency of the sparks increases with the value of the current.

In each half-wave the sparks come closer together, until the moment when the difference of potential is a maximum, then they come further apart.

61. CALDWELL.—*The Electrical Review*, London, vol. XLIV, May 19, 1899, p. 837.

Describes an electrolytic interrupter, with a hole similar to that of Simon.

62. CHILD.—*The Electrical Review*, London, vol. XLIV, May 26, 1899, p. 874.

Studies the interrupter pointed out by Caldwell, and noted particularly the rise of the electrolyte produced in the tube.

63. ERNST RUHMER.—*Elektrotechnische Zeitschrift*, vol. XX, 1899, p. 787.

Verifies the formula given by Simon (B. No. 51) and finds the resistance and voltage constants for periods equal to:

$$T = AL + B.$$

For $L = 1 \quad 2 \quad 3 \quad 4 \quad 5 \times 10^7$

The calculated frequency is: 223 264 305 346 387

The observed frequency is: 220 262 307 353 392

64. O. M. CORBINO.—*R. d. Lincei*, vol. VIII, December 17, 1899, p. 352.

Objects to the thermic theory advanced by Simon for electrolytic interrupters. Calls attention to the following experiment: An induction coil without iron being connected in a circuit with an interrupter without other self-induction, the current simply electrolyzes the liquid; the act of introducing an iron core into the coil produces interruptions.

65. WEHNELT & DONATH.—*Wiedemann Annalen*, vol. LXIX, December, 1899, p. 861.

Gives different curves for primary current in coils with the Deprez and Wehnelt interrupters. Observations made with a Braun cathode tube.

66. B. WALTER.—*Fortschritte auf dem Gebiete der Röntgenstrahlen*, vol. II, 1899.

States that there is only hydrogen at the cathode with the Wehnelt interrupter, and that a mixture of hydrogen and oxygen at the anode, and supposes that an explosion of the mixture produces an interruption of the current.

67. H. ARMAGNAT.—*Eclairage électrique*, vol. XXII, January 27, 1900, p. 121.

Theory of the rupture spark; this spark does not form when the geometrical rupture takes place, but later. The consequence is that there is a certain capacity which gives in each case the maximum length of spark as was proven by Mizuno who obtained curves giving nearly the theoretical form of the current of rupture.

68. E. RUHMER.—*Elektrotechnische Zeitschrift*, vol. XXI, April 26, 1900, p. 321.

Observes the sparks by photography and finds great irregularity with the Wehnelt, but less with the Simon interrupter.

69. K. R. JOHNSON.—*Drude Annalen*, vol. II, May, 1900, p. 179.

Discusses the theory of Arons (B. No. 35) on "The Resistance of the Rupture Spark."

70. K. R. JOHNSON.—*Philosophical Magazine*, vol. 49, 1900, p. 216.

Verifies experimentally, the law of the spark length and finds it proportional to $\frac{I_0}{\sqrt{C}}$.

71. BEATTIE.—*Philosophical Magazine*, vol. 50, 1900, p. 139.

Verifies the experiments of Rijke on the influence of the nature of poles of the interrupter and its relation to the length of the secondary spark. He measures at first the length of the secondary sparks obtained with the circuit closed, and finds that this length decreases with the volt-

age of the source. On the other hand, at the moment of rupture, the length of spark decreases when the voltage increases, at least with the platinum contacts. Studies the optimum capacity with different metals as contacts in the interrupter. This capacity is the smallest, and the secondary spark is the longest, when the contacts are of platinum; copper, zinc and carbon require greater capacity which increases in the order indicated. Gives tables and curves showing results.

72. K. R. JOHNSON.—*Drude Annalen*, vol. III, 1900, p. 438 and 744; vol. IV, 1901, p. 137.

Starts from known differential equations and by making assumptions which are not justifiable, determines that the

e.m.f. of self-induction is proportional to $\sqrt{1 - \frac{M^2}{Ll}}$. This

e.m.f. becomes zero without magnetic leakage, or, $M^2 = Ll$.

73. B. WALTER.—*Fortschritte auf dem Gebiete der Röntgenstrahlen*, vol. IV, January 25, 1901, p. 1.

Shows the importance particularly with the Wehnelt interrupter, of proportioning the coefficient of self-induction of the primary to the e.m.f. of the source in such a manner that the e.m.f. produced at the moment of closing the circuit, and that the rupture be as different as possible. Advises the use of a primary having four wires which can be connected together in various ways.

74. FR. KLINGELFUSS.—*Zeitschrift für Electrochemie*, vol. VII, May 23, 1901, p. 642. *Verhandlungen der Naturforschenden Gesellschaft, Bale*, vol. XIII.

Determines the disruptive voltage necessary for long sparks by measuring the primary voltage by the length of sparks between the terminals of the circuit and multiplying by the ratio of transformation. This method, which would be exact if the primary and secondary sparks were formed exactly at the same moment, conducts to a singular conclusion: He finds that the disruptive voltage increases with the value of the primary current, that is, with the magnitude of the secondary spark.

75. HEMSALECH.—*Doctor thesis*, Paris, June 25, 1901.

The character of a spark depends on the resistance and coefficient of self-induction in the discharge circuit. The sparks produced in the air at ordinary temperature, by a discharge of a large capacity, present this in three forms: 1st, ordinary sparks; 2d, intermittent sparks; 3d, oscillatory sparks.

By photographic observation with sensitive plate having a movement of translation greater than 100 meters per second, the author proves that the ordinary spark is composed at first of a straight luminous path, which is the first discharge, followed by curved lines more or less numerous which correspond to the auroral discharge. The luminous path is produced by the incandescence of the air broken down by the discharge. The space is afterwards filled with metallic vapors; given off by the electrodes in such a manner that the spectrum of oscillations is simply that of metals.

When the resistance of the spark is increased, the number of oscillations diminishes little by little, the discharge finishes by becoming aperiodic. If we increase the resistance still more, the discharge divides, the sparks become intermittent, the quantity of the metallic vapor formed is smaller, the spectrum of metals is no longer found except in the neighborhood of the electrodes.

If the resistance is replaced by an inductive reactance which is variable but without the use of iron, the luminous path becomes fainter, the aurora becomes more regular, and there is preponderance of metallic vapors, oscillatory discharge is obtained in which the oscillations are slower and more numerous than in the ordinary spark.

With a very high coefficient of self-induction, the luminous path disappears, the aurora remains; then the spectrum is entirely that of metal.

Introduction of iron into the induction coil decreases the speed of the oscillations and diminishes their number, the damping becomes more energetic. The Foucault currents, which develop in the core and the coil, have analogous action.

76. MIZUNO.—*Drude Annalen*, vol. IV, 1901, p. 801.

Calculates the effect produced by a non-inductive resistance R connected in shunt with a condenser, when it is charged by a primary current from an induction coil. This resistance produces an increase in the apparent resistance R' of the coil and a diminution of the apparent capacity C

$$R' = R + \frac{L}{rC} \text{ et } C' = C \frac{r}{R+r}$$

The presence of the resistance r increases the damping of the oscillations, and if r decreases below a certain limit, the discharge becomes aperiodic.

77. MIZUNO.—*Philosophical Magazine*, sixth series, vol. I, 1901, p. 246.

Studies the rôle of the coefficient of self-induction in the Wehnelt interrupter, and concludes that the spark at rupture is necessary for the operation, because it destroys the layer of steam which envelops the anode.

78. M. A. CODD.—*Electrical Review*, London, November 15, 1901, p. 789.

Puts two Wehnelt interrupters in series and observes an increase in the length of sparks and the frequency. The interrupters put in parallel operate in synchronism.

79. LORD RAYLEIGH.—*Philosophical Magazine*, vol. II, December 1901, p. 581.

Notes that a part of the energy stored in the coil cannot be utilized when there is magnetic leakage.

Studies the rôle of the iron core, and shows that its action is completely nullified if the magnetic circuit is entirely closed; the iron loses by hysteresis the energy which is stored in it. As soon as the magnetic circuit is opened, a part of the energy of the iron is rendered available.

He produces a sudden rupture of the primary circuit by shooting it apart with a gun; he obtains thus the best sparks with an ordinary interrupter and the condenser.

80. J. TROWBRIDGE.—*Philosophical Magazine*, vol. III, April 1902, p. 393.

Describes an electrolytic interrupter in which a platinum wire forming the anode is given a reciprocating movement along its axis in such a way that the area of the part immersed in the electrolyte varies rapidly.

81. J. E. IVES.—*Physical Review*, vol. XIV, June 1902, p. 280, vol. XV, p. 7.

Experimental study on the influence of the iron core and on the effect of the capacity in the secondary. Experiments all made with commercial alternating current, giving no novel results. The second part is then a tentative theory for the rupture spark. The author admits that this cannot happen if the increase in the disruptive e.m.f. as a function of time is more rapid than that of the e.m.f. of self-induction. This theory would lead one to think that the rupture should absorb all the energy and that none would be found in the secondary. The experiments of the author destroy this theory.

82. H. ARMAGNAT.—*Eclairage électrique*, vol. XXXIII, November 15, 1902, p. 217.

Discusses the memoirs of Lord Rayleigh, Ives, Walter, Klingelfuss, and others. Explains by sectionalization the difference in the results found by Walter and Oberbeck in calculating the capacity of the secondary; shows that there may exist differences in phase between the currents in the sections which tend to diminish the length of the sparks. He extends the theory of Lord Rayleigh to the case of coils having magnetic circuits almost closed, and shows that an air gap of the order of a twentieth of the total length of the magnetic circuit gives about the same conditions as a straight core.

83. J. E. IVES.—*Physical Review*, vol. XVII, September 1903, p. 175.

States that the optimum capacity differs for a coil with a mercury interrupter; according to the relative polarity of the mercury and the plunging contact.

84. H. ARMAGNAT.—*Eclairage électrique*, vol. XXXVII, November 14, 1903, p. 241.

Analyzes the numerous current curves produced with a

Blondel oscillograph; shows that this curve verifies the theory of the rupture spark. The conclusions of this study are:

The damping of the first oscillations is due to the sparks, the primary as well as the secondary.

Hysteresis appears to play an important rôle in the damping of the following oscillations.

The oscillations are not simple, at least not always; they are the resultant of several oscillations of different frequencies and damping coefficients.

The secondary current retards the demagnetization and may trouble the operation of the interrupters.

The e.m.fs. of induction developed in the two circuits are, everything else being equal, functions of the resistance opposed to the sparks and not only a function of the maximum current value in the primary.

85. X.—*Notice sur la vie et les travaux de Ruhmkorff*, 1903, published in honor of the centennial of his birth by the *Société des Electriciens du Hanovre*.

86. C. BAUR.—*Elektrotechnische Zeitschrift*, vol. XXV, January 1904, p. 77.

For the mean values, the law of disruptive voltage as a function of the thickness of the dielectric may be represented by the formula, $E = c d^3$, c being constant.

87. J. DE KOWALSKY.—*Comptes rendus*, vol. CXXXVIII, February 22, 1904, p. 487.

Measured the disruptive distances in the air between a disk 158 millimetres in diameter and a sphere 20 millimetres in diameter, both being of brass (see Fig. 49). The source of e.m.f. was a condenser charged by continuous current dynamo. The following results were obtained:

5000 volts,	distance:	0.118 centimeters
30000 "	"	1.4 "
45000 "	"	3.75 "
60000 "	"	6.9 "
65000 "	"	8.2 "

88. ERNST RUMMER.—*Konstruktion, Bau und Betrieb von Funkeninduktoren*.

Description of most of the types of German apparatus; instructions for their use; and their application to radiography. 338 figures. Hachmeister *et* That, editors, Leipzig, 1904.

89. GAGNIÈRE.—*Eclairage électrique*, vol. XXXIX, p. 115. Paper read before the *Académie des Sciences*, February 29, 1904.

Observes the secondary spark of a coil operating with a Wehnelt interrupter. Finds that there is one uni-directional discharge at both make and break of the circuit, and that the frequency of the interrupter, when determined by observing the secondary spark with a rotating mirror, varies from 400 to 600 interruptions per second, instead of from 1000 to 1500, as was formerly believed. The high frequencies were arrived at by measuring the pitch of the note produced by the interrupter. The author thinks it is possible that two explosions take place per interruption; one when the gases form, and one when they are ruptured; thus giving a note which has double the frequency of the current interruptions.

90. GAGNIÈRE.—*Archives d'Electricité médicale*, April 10, 1904, p. 243.

The gas bubbles disengaged by the electrolysis of the liquids in the Wehnelt interrupter produce an increase in the resistance, and there is a certain surface about the platinum point where the density of the current is a maximum; it is on this surface that the heating and vaporization of the liquid takes place, and therefore the rupture of the circuit. The surface in question cannot be in contact with the platinum. The author admits that the luminous phenomena of the envelope is produced between two layers of the liquid and that the anode is not heated. This explains the rapidity at which the contact is re-established. The observations of gas bubbles shows that they are disengaged in a regular manner most generally moving in a plane perpendicular to the platinum plunger and at its middle.

91. BROCA & TURCHINI.—*Bulletin de la Société internationale des Electriciens*, April 1904, p. 235.

Studied the form of the establishment of the current and the rupture by means of a hospitalier ondograph.

92. K. R. JOHNSON.—*Comptes rendus*, vol. CXXXIX, September 5, 1904, p. 477.

Constructs an interrupter of the Simon type by the aid of a glass funnel tube of which has a diameter of 7 millimeters, and a length of 10 millimeters. This tube is fastened on to a cylinder 75 millimeters in diameter, and all is immersed in a larger receptacle filled with alum and sulphuric acid. An electrode of aluminum is plunged in each vessel. When the apparatus is connected to a circuit of 110 volts, a bubble of steam is formed in the tube, the current is interrupted; afterwards the bubble escapes to the interior cylinder where it is condensed and the current re-established. This interrupter operates very slowly and independently of the constants of the circuit.

93. *Elektrotechnische Zeitschrift*, vol. XXVI, 1905, p. 382.

Description of an interrupter used with induction coils to produce high frequency discharges. The apparatus stands up well under service; the only deterioration being the consumption of the carbon. With this interrupter heavy discharges at maximum e.m.f. can be obtained. Fig. 1 shows the method of connecting the apparatus;

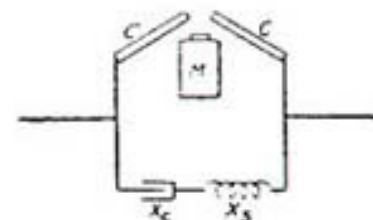

FIG. 1.

C C are carbons; *M* is an electromagnet; *X_c* and *X_s* are condensive and inductive reactances respectively.

94. A SOULIER.—*L'Industrie électrique*, vol. XII, 1904, p. 373.

Describes and gives circuit diagrams of apparatus for producing high frequency discharges; a closed magnetic circuit coil is used.

95. J. C. HUBBARD.—*Electrical Review*, London, vol. XXII, 1906, p. 129.

An experimental study of the conditions for sparking at the interrupter contacts. Includes a method for measuring the capacity of a coil.

96. W. F. LENT AND L. B. WEEKS.—*Electrical World*, vol. XLVIII, 1906, p. 214.

Instructions for the construction of a 6-inch (15-cm.) induction coil.

97. WILLIAM O. EDDY AND MELVILLE EASTHAM.—*Electrical World*, vol. XLVIII, 1906, p. 1197.

Gives theory and method of designing induction coils for use in wireless telegraphy and the production of x-rays.

98. F. W. SPRINGER.—*Electrical World*, vol. XLVIII, 1906, pp. 995, 1111 and 1242.

Theory operation and tests of induction coils used to ignite gas engines.

99. WILLIAM O. EDDY.—*Electrical World*, vol. XLIX, 1907, pp. 40 and 244.

Complete instructions for the construction of a 12-inch spark coil for all around use.

100. E. W. EHNERT.—*Elektrotechnik und Maschinenbau*, vol. XXV, 1907, pp. 337, 361 and 377.

Theory and design of induction coils; being a resumé of practice up to date.

101. F. W. SPRINGER.—*Electrical World*, vol. L, 1907, p. 1163.

Treats the design and performance of spark coils for operation in the contact, the jump spark and the vibrating jump spark systems.

102. E. J. EDWARDS.—*Electrical World*, vol. L, 1907, p. 765.

Treats the energy transferred in induction coils to ignite gas engines by the contact system. Gives test results and shows the relations existing between the period of contact, the coefficient of self-induction, the e.m.f. impressed on the primary, and the energy stored in the system. Also gives the following equation for determining the number

of dry cells (1.5 volts per cell) required for a given service.

$$n = 0.4 T + 3,$$

wherein T is the number of hours of operation per day.

103. J. G. CHARVET.—*Eclairage électrique*, vol. LIII, 1907, p. 438.

Describes an ignition system invented by Sir Oliver Lodge. Fig. 2 shows a schematic diagram of the connections; I is an induction coil; g an auxiliary spark gap; $C C$ condensers; R a high resistance representing the leakage resistance in shunt with the spark plug P . The condensers being connected through R become charged to a

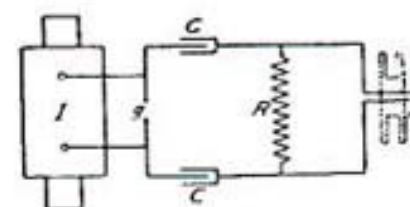

FIG. 2.

potential corresponding to the maximum e.m.f. generated by the coil, or to that corresponding to the breakdown e.m.f. of the gap, g . When the spark is formed at g , full e.m.f. is impressed across the spark plug P . If R is too great, the charging rate of the condensers is reduced; if it is too small, the current across the plug P is reduced. The advantage in this system lies in the fact that careful insulation of the high tension side is not necessary.

104. W. VON ULJANIN.—*Physicalische Zeitschrift*, vol. 8, 1907, p. 699.

Describes a new form of hole interrupter which operates for months without giving trouble. The diaphragms are made of thin porcelain thimble-shaped tubes, having a small perforation in the bottom from $\frac{1}{4}$ to 2 millimeters in diameter. Each thimble is inserted in the bottom of a beaker in a hole, forced to fit and held in position by a short piece of rubber tubing, which surrounds it. The beaker is placed in a short vessel which contains the same

kind of liquid as does the beaker. The electrodes are thin leaden coils wound in spirals, one inside and one outside the beaker. The latter is so bent as to envelope the lower portion of the thimble. The two ends of each coil emerge from the liquid, and during operation of the interrupter, they carry a current of cold water. The beaker may be fitted with several holes in the bottom in which thimbles can be inserted and kept in reserve by closing them with rubber stoppers. When using the largest size hole, the author operated the interrupter satisfactorily with 12 amperes.

INDEX.

- A. E. G. mercury turbine interrupter**, 132.
synchronous turbine interrupter, 147.
Air-gap resistance, 82.
Aluminum valve, 149.
Arons interrupter, 137.
Aster automobile ignition, 182.
Bauer's law, 74.
Break period, 19 to 25.
Building up curves, 17 to 19.
Capacity, apparent, 43.
 charging, 170.
 measurement, 88.
 optimum, 30, 35, 91.
 in secondary circuit, 45.
Carpentier electrolytic interrupter, 142.
 interrupter, 122.
Cathodic valves, 174.
Characteristic curve, 90.
Circuit-breakers, 166.
Colley's treatment of the break period, 20.
Coefficient of
 induction, closed magnetic circuit, 23.
 open magnetic circuit, 24.
 mutual induction, 15.
 measurement, 89.
 self-induction, 15.
 formula, 111.
 measurement, 89.
 variation, 54.
Condensers, 3, 105.
 between interrupter contacts, 11.
 connecting wires, 167.
 connection, 107.
 construction, 106.
 grouping, 107.
 short-circuit, location, 93.
Connecting wires, 166.
Construction of induction coils, 94 to 118.
 of interrupters, 119 to 150.
Contact-duration, 86.
 initial rapidity, limit, 41.
 non-sparking metal, 40.
 rapid break, 40.
Contremoulins & Gaiffe's interrupter, 125.
Core dimensions, 108.
 effect of, 49.
Counter e.m.f. during make, 18.
Crookes tubes, operation, 186.
Current density, 109.
 discharge, shifting point, 37.
 during make, 18.
Damping of oscillations by spark, 40.
d'Arsonval high frequency transformer, 156.
 interrupter, 120.
 & Gaiffe high frequency transformer, 157.
Definitions, 1.
Depeze interrupter, 120.
Dielectrics, 104.
 desirable properties, 105.
Dion automobile ignition, 182.
Disruptive e.m.f. See striking e.m.f.
 discharge, 77.
Efficiency of induction coils, 83.
 secondary closed through capacity, 84.
 secondary closed through resistance, 84.
 test, 87.
 total, 84.
 value, 85.
Eisemann ignition, 183.
Electricity stored in capacity, 42.

- Electrolytic interrupter, 14.
valves, 149.
E.m.fs. at rupture, 26.
Energy absorbed in hysteresis, 50.
available, 51.
distribution in coil, 32.
input, 83.
stored in magnetic field, 83.
Equivalent resistance of X-ray tubes, 172.
Experimental demonstrations, 29.

Faults in coils, 92.
Ferrié resonator, 159.
Foucault interrupter, 126.

Gaiffe-Gallot electrolytic interrupter, 143.
Gas-engine operation, 177.
Geissler tubes, operation, 186.
Glass, puncturing, 186.
Grimschl interrupter, 136.

Helmholtz law, 17.
High frequency coils operated from lighting systems, 161.
Tesla transformer, 151.
Hiller coil, 102.
Hirschmann interrupter, 134.
History, 7 to 14.
Hole interrupter. See Interrupter, electrolytic.
Hysteresis, energy absorbed in, 50.
Ignition.
coils, 96.
equivalent sparks, 185.
gas engines, 177.
regulation of advance, 181.
spark precision, 179.
timing, 178.
vibrating interrupters, 180.
Induced e.m.fs., 23.
Induction coils.
dimensions, 107.
length, 108.
installation, 164.
interconnection, 169.
proportions, 107.
sectionalizing of, 11.
types, 113.
uses, 164 to 187.
winding outfit, 97.
Installation of induction coils, 164.

Insulating tube, dimensions, 113.
puncture, location, 93.
Interconnection of coils, 12.
Interrupters, 2.
a.c., 145.
arc lamp, 138.
atoms, 122.
capillary tube, 138.
construction, 119 to 150.
electrolytic, a.c., 70.
performance, 71.
construction, 138.
cooling, 141.
current, reversal, 65.
experimental results, 60.
efficiency, 69.
field of application, 145.
frequency, 60.
heating, 142.
hole adjustment, 145.
type, 144.
mean value of current, 63.
multiple anode, 110.
period, 68.
phenomena, 63.
pressure, effect, 65.
resistance, 66.
steel wire, 143.
temperature, effect, 65.
temperature rise, 63.
theory, 60 to 71.
wave-form, 61.
wear compensation, 113.
high frequency, 136.
low voltage, 124.
mechanical, 15 to 59.
complete period, 25.
general discussion, 15 to 17.
mercury, 12, 126.
special, 137.
performance, 4.
periods, 4.
rotating contact, 120.
sliding amalgamated contact, 131.
solid contacts, 119.
turbine, 132.
a.c., 147.
vacuum, 12, 136.
Wehnelt, construction, 138.
Inventor of the induction coil, 7.
Iron core construction, 94.
effect, 49.
Ives theory, 34.

- Jirotko Levy electrolytic interrupter, 141.

Klingelfuss coil, 101.
Koch rectifier, 148.

Layer winding construction, 96.
Lecarme & Michel interrupter, 125.
Luhne interrupter, 137.

Max Levy mercury turbine interrupter, 133.
Magnetic circuit, 1.
Magnetizing force, 110.
Magneto and coil ignition, 183.
Magneto system of ignition conditions, 183.
Make and break ignition, 183.
Make period, 17 to 19.
Margot interrupter, 136.
Medical coils, 187.
Mercury, pulverization, 130.
Mizuno's experiments, 30.
Moore interrupter, 136.
Open circuits, location, 92.

Operation.
e.m.f. maximum, 167.
one terminal grounded, 167.
secondary closed through resistance, 27.
Optimum capacity, 30.
experimental determination, 91.
explanation, 35.
Oscillations caused by secondary capacity, 43.
Oudin's resonator, 158.
Ozone production, 186.

Pallich, electrolytic interrupter, 143.
Penetrative power of X-rays, 173.
Period of oscillation, 22.
Permeability, variation, 54.
Pies, assembly, 98.
construction, 97.
thickness, 98.
Pollak, aluminum rectifier, 149.
Power of coils, 83.
Primary coil, construction, 94.
dimensions, 108.

Primary current, direction, 107.
during discharge, 20.
oscillograms, electrolytic interrupter, 61.
Primary efficiency, 83.
Primary e.m.f. relation to secondary discharge, 57.
Primary turns, 110.
Primary wire, 109.
Protection of induction coils, 166.

Radignet, interrupter, 125.
Radiography, requirements, 172.
Rating of induction coils, 166.
Ratio of transformation, 24.
practice, 112.
Rectifier, aluminum, 149.
electromagnetic, 148.
Regulation of induction coils, 164.
Resistance, measurement, 88.
of spark, 32.
Resonance, 46.
Resonators, 158.
Rheostats, 164.
Rochefort, coils, 100.
interrupter, 128.
Ruhmer, electrolytic interrupter, 144.
Rzewerki, electrolytic interrupter, 142.

Secondary capacity, effect, 41, 48.
Secondary circuit, 2.
Secondary coil, construction, 96.
dimensions, 108.
profile, 102.
Secondary current, 72.
duration, 59.
during discharge, 20.
value, 26.
Secondary discharge, 19.
effect, 56.
Secondary efficiency, 84.
Secondary e.m.f., 24.
Secondary turns, 111.
Secondary wire, 113.
Section construction, 97.
Shifting points, 37.
effect, 39.
Short-circuits, location, 92.
Siemens & Halske, electrolytic interrupter, 139.
Simms-Bosch, ignition, 183.

- Simon-Caldwell, a.c., electrolytic interrupter, 144, 148.
- Spark at interrupter, 31, 34.
lag, 38.
- Spark plug, effect of dirt, 185.
- Spark resistance, 32.
- Spark, 75.
phenomena, 76.
between point and plate, 75.
properties, 79.
- Spectroscopy, requirements, 170.
- Spottiswoode coil, 13.
- Striking e.m.f., 33, 72.
between plate and needle point, 73.
pressure effect, 75.
with rapid interrupters, 82.
- Temperature rise of induction coils, 167.
- Tesla oscillators, requirements, 169.
- Tesla resonator, 158.
- Tesla transformer, 151.
period of oscillation, 154.
principle, 151.
transformation coefficient, 155.
- Testing induction coils, 90.
interrupter suitable for, 91.
- Theory, general, 1 to 6.
- Thomson & Shand, electrolytic interrupter, 140.
- Types of induction coils, 113.
- Unipolar coils, 100.
- Uses of induction coils, 164.
- Villard, a.c. interrupter, 146.
cathodic valves, 174.
interrupter, 129.
mercury jet interrupter, 138.
- Winding outfit, 97.
- Wireless telegraphy, requirements, 170.
- X-rays, 14.
tubes, direction of current, 167.
interrupter suitable for, 173.
operation, 172.